

## Schema di collegamento - Connecting diagram

Valvola 3/2 NC  
Valve 3/2 NC

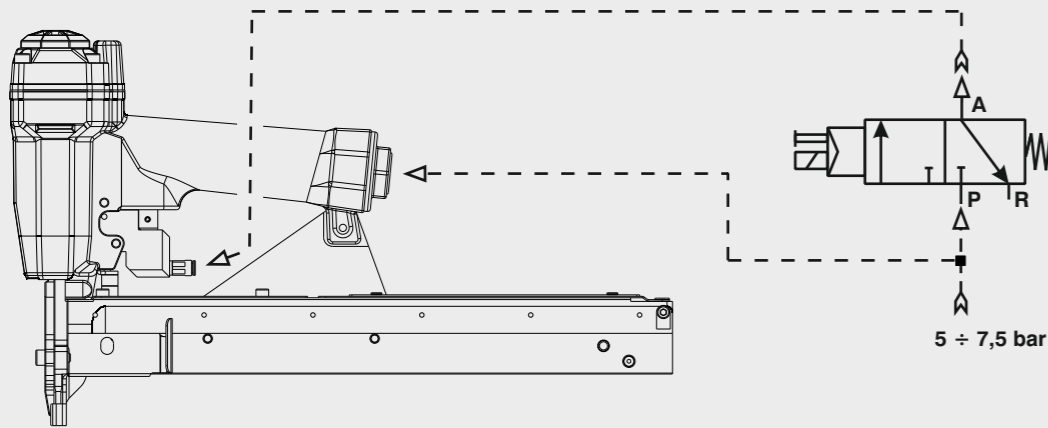

## Caricamento - Loading

Caricamento da sopra  
Top load magazine

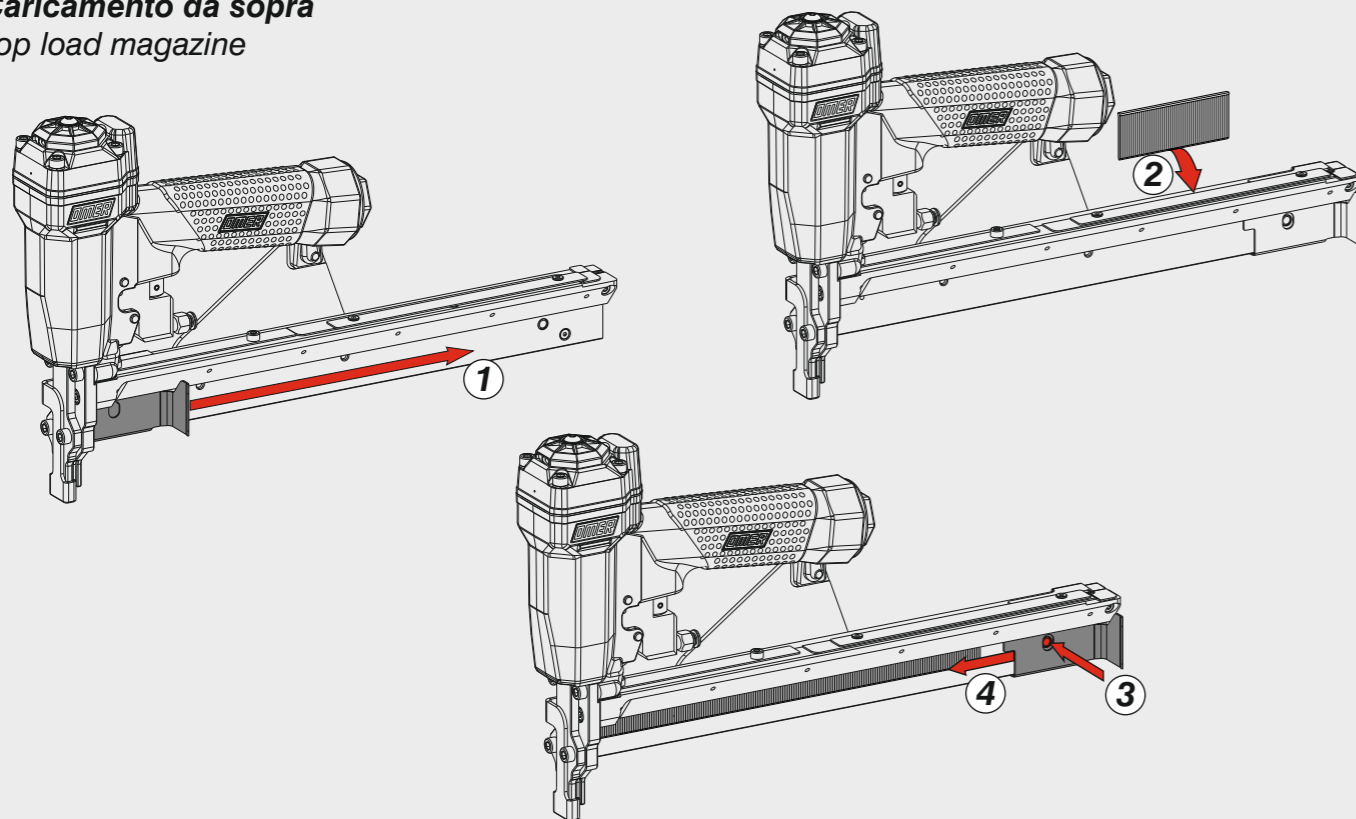

Dotazioni - Equipment - Ausrüstung - Équipements - Equipamiento - Παρεχόμενα  
Equipamento - Uitrusting - Udstyr

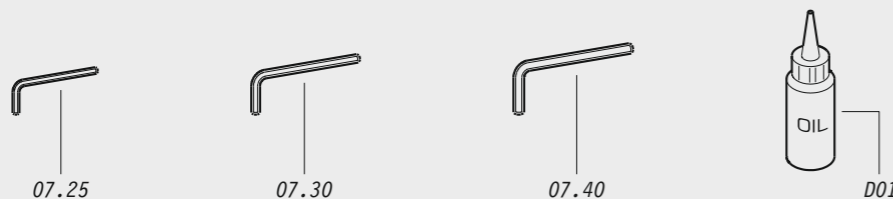

# OMER

**Manuale d'uso, manutenzione e parti di ricambio**  
**Use, maintenance and spare parts manual**  
**Gebrauchsanweisung, Instandhaltungsrichtlinien und Ersatzteile**  
**Manuel d'utilisation, entretien et pièces de rechange**  
**Manual de uso, mantenimiento y repuestos**  
Εγχειρίδιο χρήσης, συντήρησης και ανταλλακτικών  
**Manual de utilização, manutenção e partes sobresselentes**  
**Handleiding voor gebruik, onderhoud en wisselstukken**  
**Brugsanvisning, vedligeholdelse og reservedelsliste**

**Parte 2**  
**Part 2**  
**Teil 2**  
**Partie 2**  
**Part 2**  
2<sup>ο</sup> Μέρος  
**Parte 2**  
**Deel 2**  
**Del 2**



# 12.40 CL2-51

cod. 12212540-51

12212540-51\_1240CL2-51\_2 120520 IV

### Dati tecnici

Technical data  
Technische daten

### Données techniques

Datos técnicos  
Τεχνικά χαρακτηριστικά

### Dados técnicos

Technische gegevens  
Teknische data

<b>Misure impiegabili mm</b> Usable lengths mm Gebrauchliche Längen mm	Mesures utilisables mm Medidas que se pueden emplear mm Διαστάσεις σε μμ	Medidas que se podem utilizar mm Te gebruiken lengtes in mm Brugbare længder i mm	<b>12 ÷ 40</b>
<b>Capacità caricatore n° punti</b> Magazine capacity No. of fasteners Magazinkapazität Nägel	Capacité chargeur n° de points Capacidad cargador n° puntos Δυνατότητα γεμιστέρα, σπινδύτερος	Capacidade carregador n° pontos Capaciteit magazijn in aantal spijkers Kapacitet af magasin antal klemme	<b>210</b>
<b>Pressione d'esercizio</b> Working pressure Betriebsdruck	Pression de fonctionnement Presión de trabajo Πίεση λειτουργίας ατμ.	Pressao de trabalho Werkdruk Arbejds tryk bar	<b>5 ÷ 7,5 bar</b> <b>70 ÷ 105 psi</b>
<b>Consumo aria litri/colpo</b> Air consumption litres/shot Luftverbrauch Liter/Schlag	Consommation air litre/coup Consumo aire-litros/golpe Κατανοση αερα λ/ξτπημα	Consumo ar litro/golpe Luchtverbruik liter/schot Luftforbrug liter/skud	<b>0,34</b>
<b>Peso kg</b> Weight kg Gewicht kg	Poids kg Peso kg Βαρος κγ	Peso kg Gewicht in kg Vaegt kg	<b>1,68</b>
<b>Dimensioni (AxBxH) mm</b> Dimensions mm Größe mm	Dimension mm Dimensiones mm Δυνατότητα γεμιστέρα, σπινδύτερος	Dimencoes mm Afmetingen in mm Dimensioner mm	<b>365x50x220</b>
<b>EN 12549 :1999 ISO 3744 :1994</b>			
<b>Potenza sonora emessa</b> Emitted sound power Ausgestrahlte Lärmintensität	Puissance acoustique émise Potencia sonora emitida Ακουστική πίεση στη θέση χειριστου	Potência sonora emitida Uitgestraalde geluidssterkte Udsendt lydstrykke	<b>88,5 dB(A)</b>

**Tipo di punto**  
Type of fastener  
Befestigungselement  
Type d'agrafe  
Tipo de punto  
Τύπος καρφιού  
Tipo de ponto  
Type nietjes  
Tilspændingstype

### Brads 12

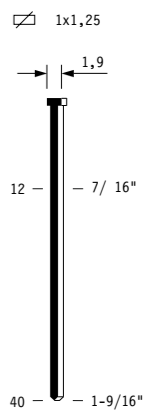

Head width: .075"  
Gauge: 18

**DO NOT  
HANDHELD  
THIS TOOL**



Parti di ricambio - Spare parts - Ersatzteile - Pièces de rechange - Piezas de repuesto  
Ανταλλακτικά - Partes sobresselentes - Wisselstukken - Reservedele

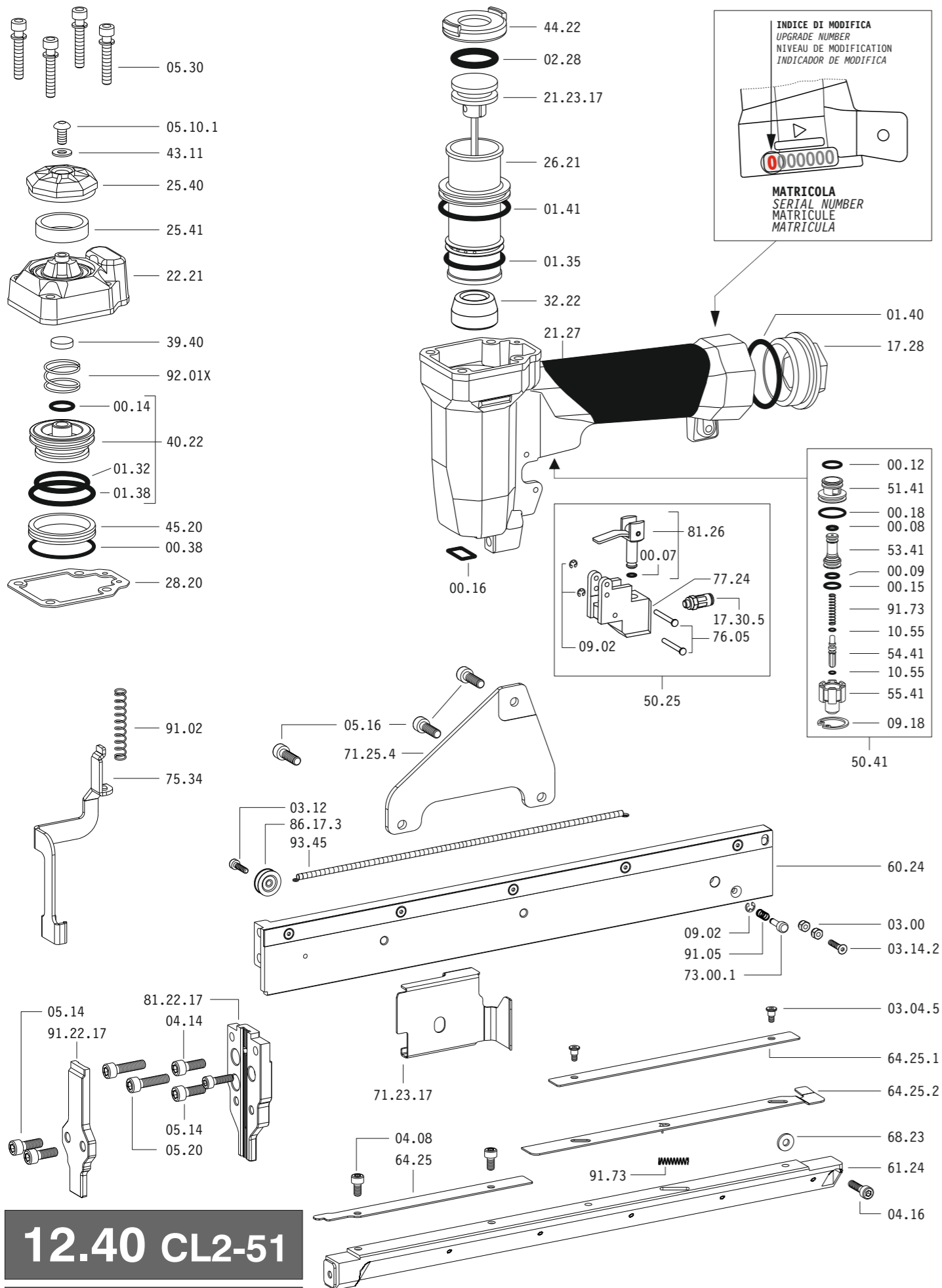

**12.40 CL2-51**

cod. 12212540-51

Parti di ricambio - Spare parts - Ersatzteile - Pièces de rechange - Piezas de repuesto  
Ανταλλακτικά - Partes sobresselentes - Wisselstukken - Reservedele

Cod.	Descrizione	Description
00.07	O-Ring	O-Ring
00.08	O-Ring	O-Ring
00.09	O-Ring	O-Ring
00.12	O-Ring	O-Ring
00.14	O-Ring	O-Ring
00.15	O-Ring	O-Ring
00.16	O-Ring	O-Ring
00.18	O-Ring	O-Ring
00.38	O-Ring	O-Ring
01.32	O-Ring	O-Ring
01.35	O-Ring	O-Ring
01.38	O-Ring	O-Ring
01.40	O-Ring	O-Ring
01.41	O-Ring	O-Ring
02.28	O-Ring	O-Ring
03.04.5	Vite	Screw
03.12	Vite	Screw
03.14.2	Vite	Screw
04.08	Vite	Screw
04.16	Vite	Screw
05.10.1	Vite	Screw
05.14	Vite	Screw
05.16	Vite	Screw
05.30	Vite	Screw
07.25	Chiave esagonale	Hex. bar wrench
07.30	Chiave esagonale	Hex. bar wrench
07.40	Chiave esagonale	Hex. bar wrench
09.02	Anello elastico	Elastic ring
09.18	Anello elastico	Elastic ring
10.55	O-Ring	O-Ring
17.28	Tappo	Inlet cap
17.30.5	Attacco	Connection
21.27	Corpo	Body
22.21	Testa	Head
25.40	Deflettore	Exhaust deflector
25.41	Silenziatore	Silencer
26.21	Cilindro	Cylinder
28.20	Guarnizione testa	Head gasket
32.22	Ammortizzatore	Bumper
39.40	Guarnizione scarico	Exhaust seal
40.22	Valvola completa	Valve ass'y
43.11	Rondella	Washer
44.22	Guarnizione	Gasket
45.20	Anello valvola	Ring
50.25	Comando a distanza	Remote control
50.41	Pulsante completo	Trigger valve ass'y
51.41	Boccola pulsante	Trigger valve housing
53.41	Pistone servovalvola	Valve piston
55.41	Raccordo pulsante	Bush
60.24	Guida sx	Left guide
61.24	Guida dx	Right guide
64.25	Carter	Hold down
64.25.1	Carter posteriore	Rear hold down
68.23	Rondella	Washer
71.25.4	Reggicaricatore	Support
73.00.1	Perno	Pin
75.34	Sicura	Safety
76.05	Perno	Pin
77.24	Guida	Guide
81.26	Pistoncino	Piston
91.02	Molla	Spring
91.05	Molla	Spring
91.73	Molla	Spring
92.01X	Molla	Spring
93.45	Molla	Spring
21.23.17	Battente	Driver
71.23.17	Spingipunto	Pusher
81.22.17	Controtestina	Nose
91.22.17	Testina	Nose plate
D01	Bocchetta	Oiler

Guarnizioni - O-Rings - Dichtungen - Joints - Kit O-rings - Λαστιχακια - Kit O-rings - Pakninger

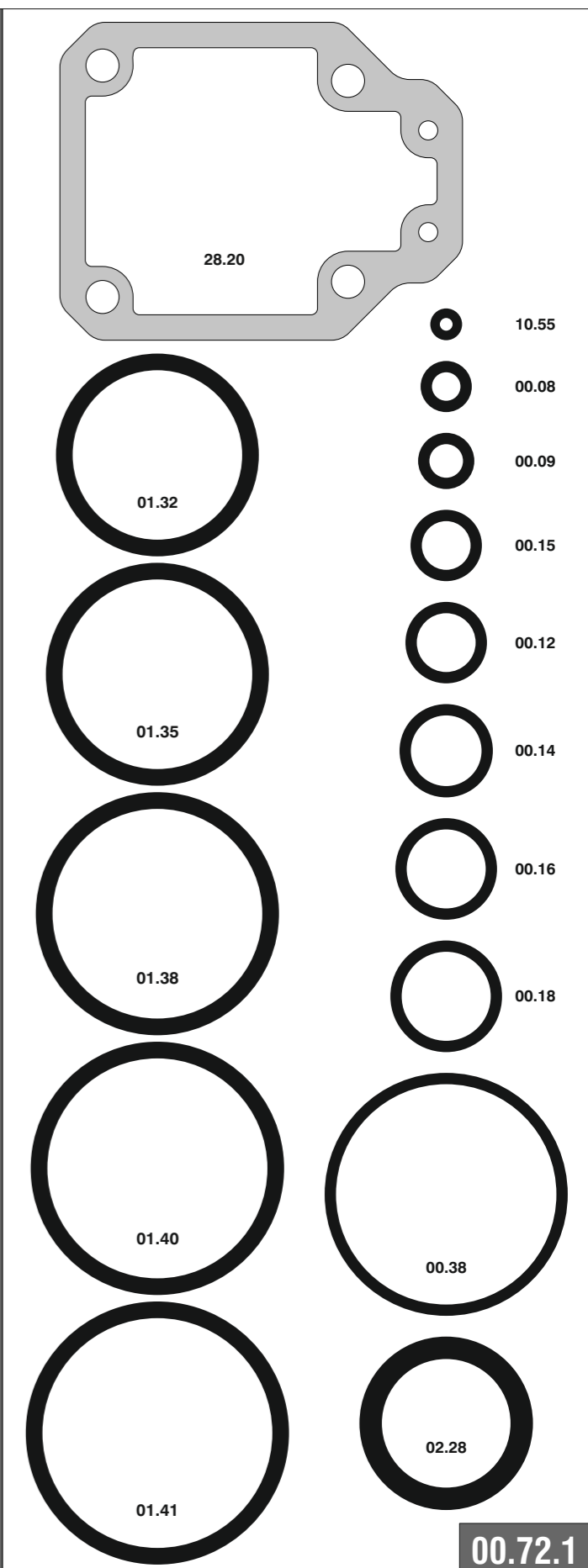

**12.40 CL2-51**

cod. 12212540-51

Indice di modifica  
Upgrade number

**2**

# Disinceppamento - Jam clearing

