

## Azionamento - Actuation

### Azionamento a contatto Contact actuation

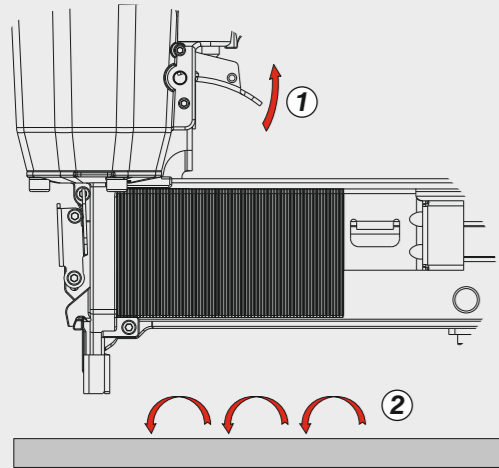

Oppure - Or

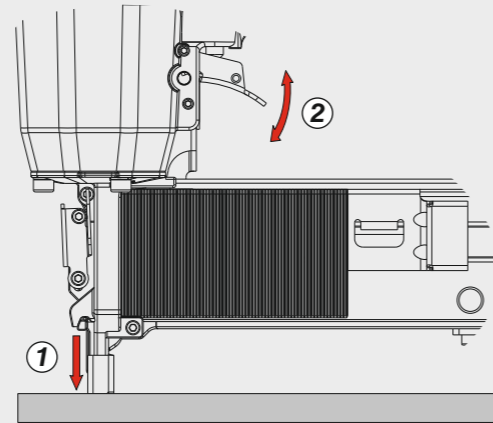

## Caricamento - Loading

### Caricamento da sopra Top load magazine

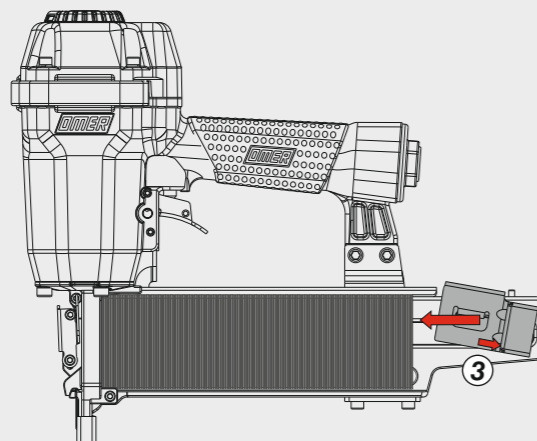
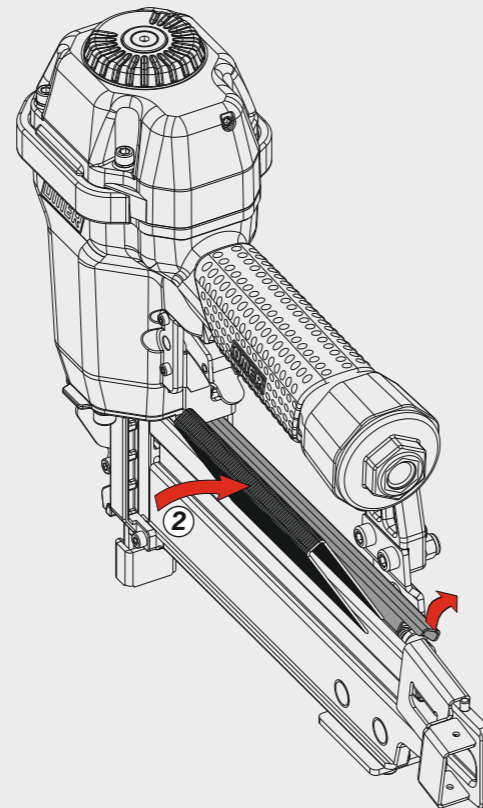
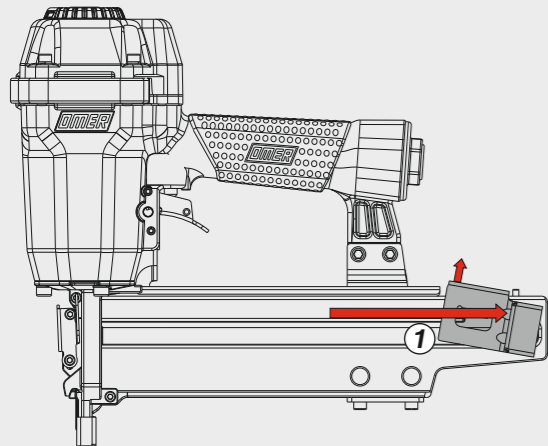

# OMER

**Manuale d'uso, manutenzione e parti di ricambio**  
**Use, maintenance and spare parts manual**  
**Gebrauchsanweisung, Instandhaltungsrichtlinien und Ersatzteile**  
**Manuel d'utilisation, entretien et pièces de rechange**  
**Manual de uso, mantenimiento y repuestos**  
**Εγχειρίδιο χρήσης, συντήρησης και ανταλλακτικών**  
**Manual de utilização, manutenção e partes sobresselentes**  
**Handleiding voor gebruik, onderhoud en wisselstukken**  
**Brugsanvisning, vedligeholdelse og reservedelsliste**

**Parte 2**  
**Part 2**  
**Teil 2**  
**Partie 2**  
**Part 2**  
**2° Μέρος**  
**Parte 2**  
**Deel 2**  
**Del 2**



## M2.65 DA

cod. 1848210DA

1848210DA\_M265DA\_4 190520 IV



**Warning:** Please read the instructions and warnings for this tool carefully before use. Failure to do so could lead to serious injury.

Dati tecnici Technical data Technische daten	Données techniques Datos técnicos Τεχνικά χαρακτηριστικά	Dados técnicos Technische gegevens Teknische data
--	--	---

<b>Misure impiegabili mm</b> Usable lengths mm Gebrauchliche Längen mm	Mesures utilisables mm Medidas que se pueden emplear mm Διαστάσεις σε μμ	Medidas que se podem utilizar mm Te gebruiken engtes in mm Brugbare længder i mm	<b>20 ÷ 65</b>
<b>Capacità caricatore n° punti</b> Magazine capacity No. of fasteners Magazinkapazität Nägel	Capacité chargeur n° de points Capacidad cargador n° puntos Δυνατότητα γεμιστέρα, σπινδύλες	Capacidade carregador n° pontos Capaciteit magazijn in aantal spijkers Kapacitet af magasin antal klemme	<b>145</b>
<b>Pressione d'esercizio</b> Working pressure Betriebsdruck	Pression de fonctionnement Presión de trabajo Πίεση λειτουργίας ατμ.	Pressao de trabalho Werkdruk Arbejds tryk bar	<b>5 ÷ 7,5 bar 70 ÷ 105 psi</b>
<b>Consumo aria litri/colpo</b> Air consumption litres/shot Luftverbrauch Liter/Schlag	Consommation air litre/coup Consumo aire-litros/golpe Κατανοση αερα λ/ξτπημα	Consumo ar litro/golpe Luchtverbruik liter/schot Luftforbrug liter/skud	<b>1,40</b>
<b>Peso kg</b> Weight kg Gewicht kg	Poids kg Peso kg Βαρος κγ	Peso kg Gewicht in kg Vaegt kg	<b>2,14</b>
<b>Dimensioni (AxBxH) mm</b> Dimensions mm Größe mm	Dimension mm Dimensiones mm Δυνατότητα γεμιστέρα, σπινδύλες	Dimencoes mm Afmetingen in mm Dimensioner mm	<b>355x98x290</b>

EN 12549 :1999	ISO 11201 :1995	
<b>Pressione sonora in pos. operatore</b> Sound pressure at the workstation Lärmintensität am Arbeitsplatz	Pression acoustique près de l'opérateur Presión sonora en posición encargado Ακουστική πίεση στη θέση χειριστού	Intensidade sonora perto do operador Geluidssterkte op de werkplek Lydstyrke på operatorposten
		<b>L<sub>pA,1s</sub></b> (Rif. 20μPa) <b>86,7 dB(A)</b>

EN 12549 :1999	ISO 3744 :1994	
<b>Potenza sonora emessa</b> Emitted sound power Ausgestrahlte Lärmintensität	Puissance acoustique émise Potencia sonora emitida Ακουστική ισχύς	Potência sonora emitida Uitgestraalde geluidssterkte Udsendt lydstrykke
		<b>L<sub>WA,1s</sub></b> (Rif. 1pW) <b>97,9 dB(A)</b>

EN 28662 :1992	ISO 5349 :1986	ISO 8662 -11	
<b>Valore medio ponderato di vibrazione sull'impugnatura max.33 colpi</b> Weighted mean value of vibration on the grip max.33 shots Mitteler Vibrationswert, am Griff gemessen max.33 Schläge	Valeur moyenne pondérée de vibration mesurée sur la poignée max.33 coups Valor medio ponderado de vibracion medida en la empunadura max.33 golp Μεσος ορος μετρησης κραδασιμον στη χειρολαβη μαξ.33 ξτπημα	Valor medio ponderado de vibracao medida no punho max.33 golpes Gewogen gemiddelde vibratiewaarde max.33 schot Middelvaardi af vibrationer på handtaget max.33 skud	<b>Bump a<sub>h,w</sub></b> <b>4,75 m/s<sup>2</sup></b>

**Tipo di punto**  
Type of fastener  
Befestigungselement  
Type d'agrafe  
Tipo de punto  
Τυπος καρφιου  
Tipo de ponto  
Type nietjes  
Tilspændingstype

**M2**

1,40x1,60

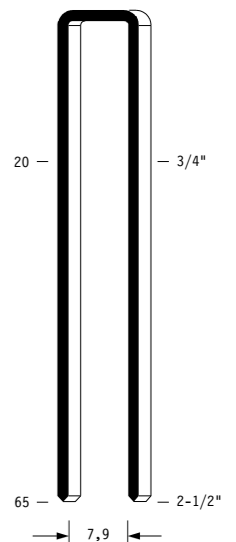

Crown: .421" (7/16")  
Gauge: 16

Parti di ricambio - Spare parts - Ersatzteile - Pièces de rechange - Piezas de repuesto  
Ανταλλακτικά - Partes sobresselentes - Wisselstukken - Reservedele

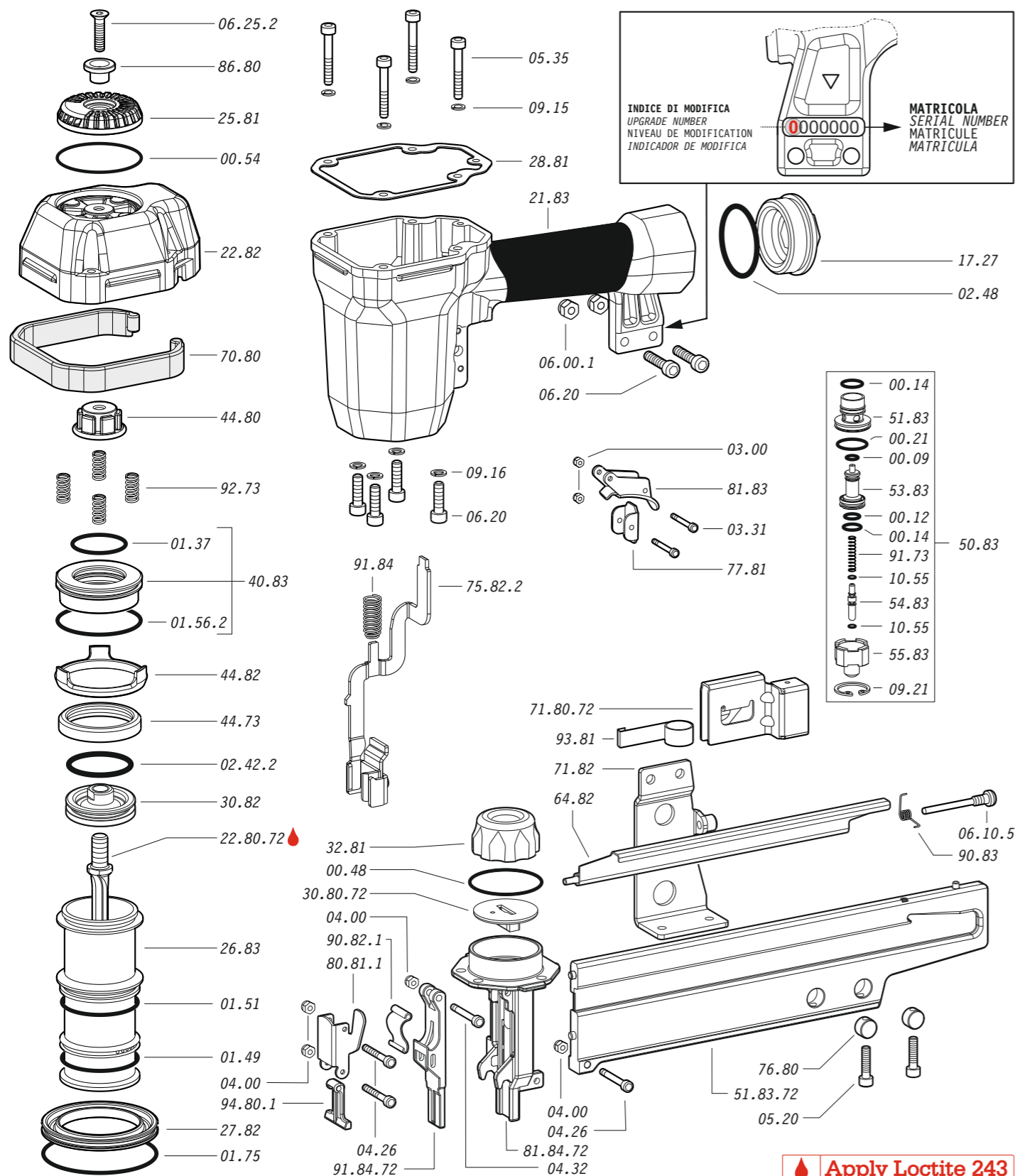

Dotazioni - Equipment - Ausrüstung - Équipements - Equipamiento - Παρεχόμενα  
Equipamento - Uitrusting - Udstyr

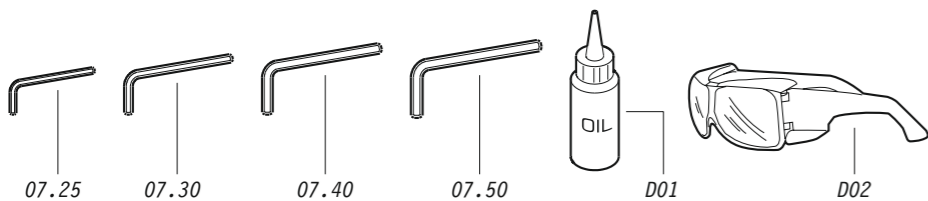

**M2.65 DA**

cod. 1848210DA

Parti di ricambio - Spare parts - Ersatzteile - Pièces de rechange - Piezas de repuesto  
Ανταλλακτικά - Partes sobresselentes - Wisselstukken - Reservedele

Cod.	Descrizione	Description
00.09	O-Ring	O-Ring
00.12	O-Ring	O-Ring
00.14	O-Ring	O-Ring
00.21	O-Ring	O-Ring
00.48	O-Ring	O-Ring
00.54	O-Ring	O-Ring
01.37	O-Ring	O-Ring
01.49	O-Ring	O-Ring
01.51	O-Ring	O-Ring
01.56.2	O-Ring	O-Ring
01.75	O-Ring	O-Ring
02.42.2	O-Ring	O-Ring
02.48	O-Ring	O-Ring
03.00	Dado	Nut
03.31	Vite	Screw
04.00	Dado	Nut
04.26	Vite	Screw
04.32	Vite	Screw
05.20	Vite	Screw
05.35	Vite	Screw
06.00.1	Dado	Nut
06.10.5	Vite	Screw
06.20	Vite	Screw
06.25.2	Vite	Screw
07.25	Chiave esagonale	Hex. bar wrench
07.30	Chiave esagonale	Hex. bar wrench
07.40	Chiave esagonale	Hex. bar wrench
07.50	Chiave esagonale	Hex. bar wrench
09.15	Rondella	Washer
09.16	Rondella	Washer
09.21	Anello elastico	Elastic ring
10.55	O-Ring	O-Ring
17.27	Tappo	Inlet cap
21.83	Corpo	Body
22.82	Testa	Head
25.81	Deflettore	Deflector
26.83	Cilindro	Cylinder
27.82	Anello cilindro	Cylinder ring
28.81	Guarnizione testa	Head gasket
30.82	Pistone	Piston
32.81	Ammortizzatore	Bumper
40.83	Valvola completa	Valve ass'y
44.73	Guarnizione cilindro	Cylinder gasket
44.80	Ammortizzatore	Bumper
44.82	Distanziale	Spacer
50.83	Pulsante completo	Trigger valve ass'y
51.83	Boccola pulsante	Trigger valve housing
53.83	Pistone servovalvola	Valve piston
54.83	Pulsante	Trigger valve
55.83	Raccordo pulsante	Bush
64.82	Carter	Hold down
70.80	Protezione	Guard
71.82	Reggicaricatore	Support
75.82.2	Sicura	Safety
76.80	Inserito	Nut screw
77.81	Guida sicura	Safety guide
80.81.1	Grilletto testina	Nose plate lock
81.83	Grilletto comando	Trigger
86.80	Boccola	Bush
90.82.1	Molla	Spring
90.83	Molla	Spring
91.73	Molla	Spring
91.84	Molla	Spring
92.73	Molla	Spring
93.81	Molla	Spring
94.80.1	Tirante	Connecting rod
22.80.72	Battente	Driver
30.80.72	Guida battente	Driver Guide
51.83.72	Caricatore	Magazine
71.80.72	Spingipunto	Pusher
81.84.72	Controtestina	Nose
91.84.72	Testina	Nose plate
D01	Bocchetta olio	Oiler
D02	Occhiali protettivi	Protective goggles

Guarnizioni - O-Rings - Dichtungen - Kits O-Rings - Ασπταγκια - Kit O-Rings - Pakninger

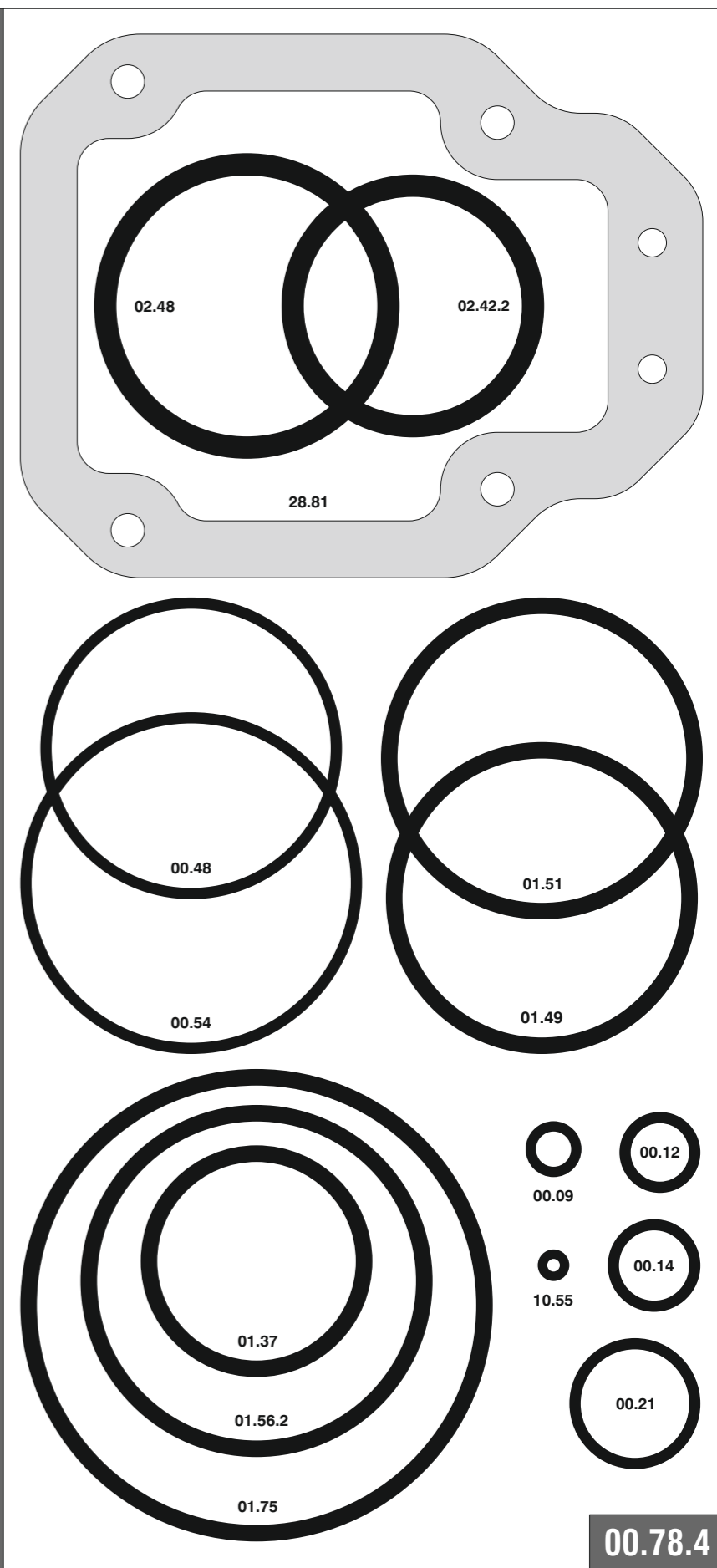

**M2.65 DA**

cod. 1848210DA

Indice di modifica  
Upgrade number

**4**

## Disinceppamento - Jam clearing

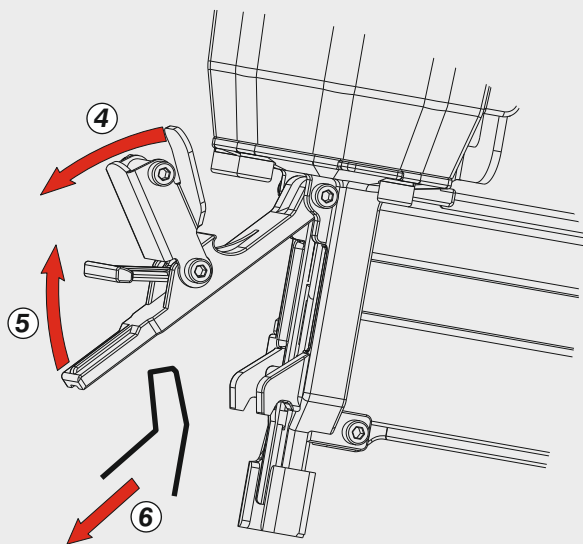
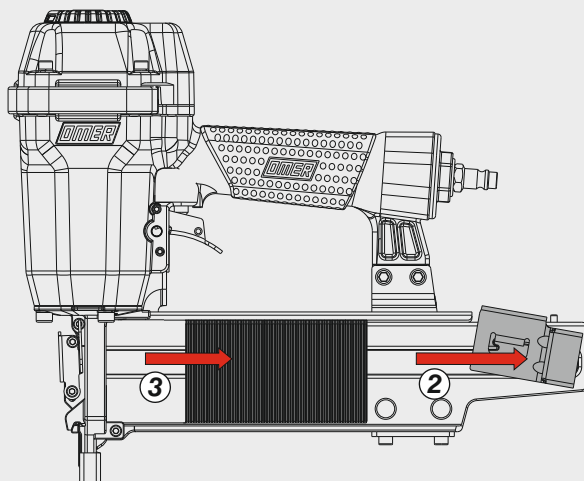
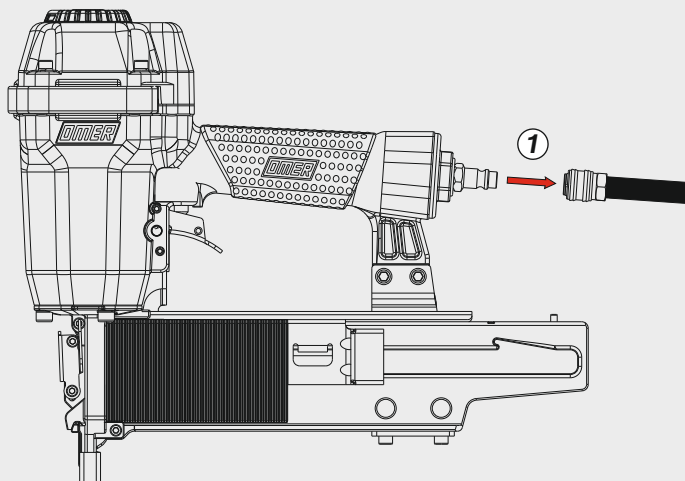

## Regolazione profondità - *Depth adjustment*

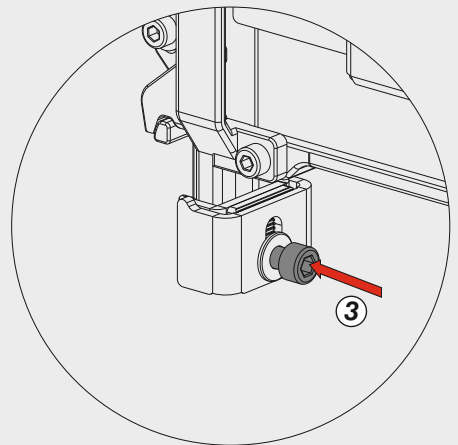
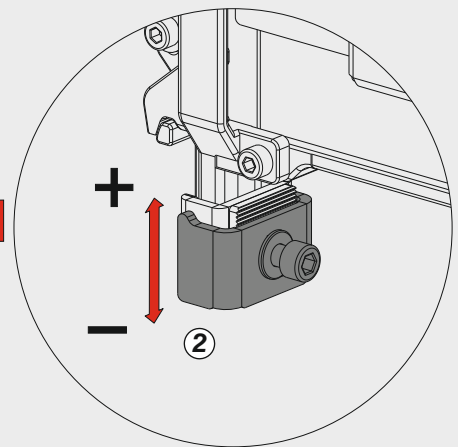
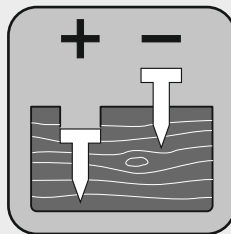
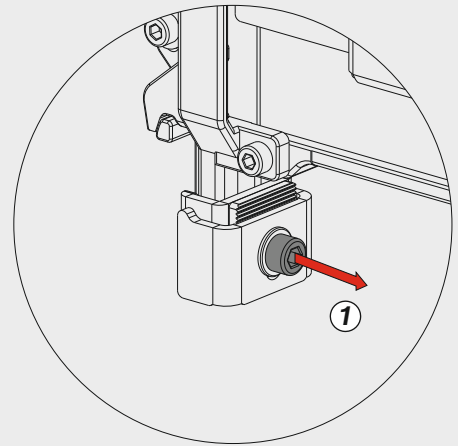
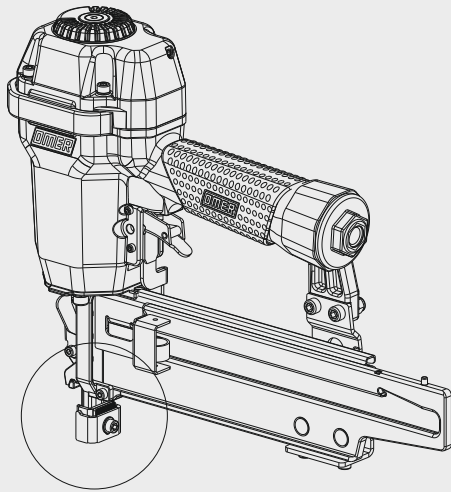

## Accessori a richiesta - *On request devices*

**Azionamento sequenziale singolo**  
*Single sequential actuation*

Cod. 81.83.1K

