

Dati tecnici - Technical data

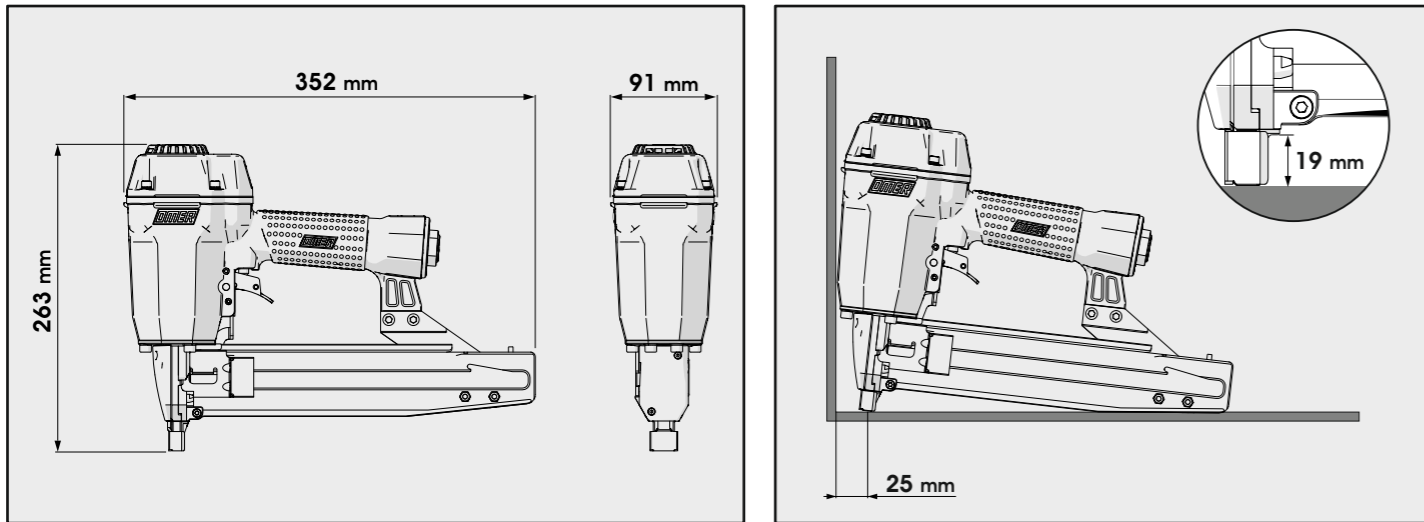

Caratteristiche - Features

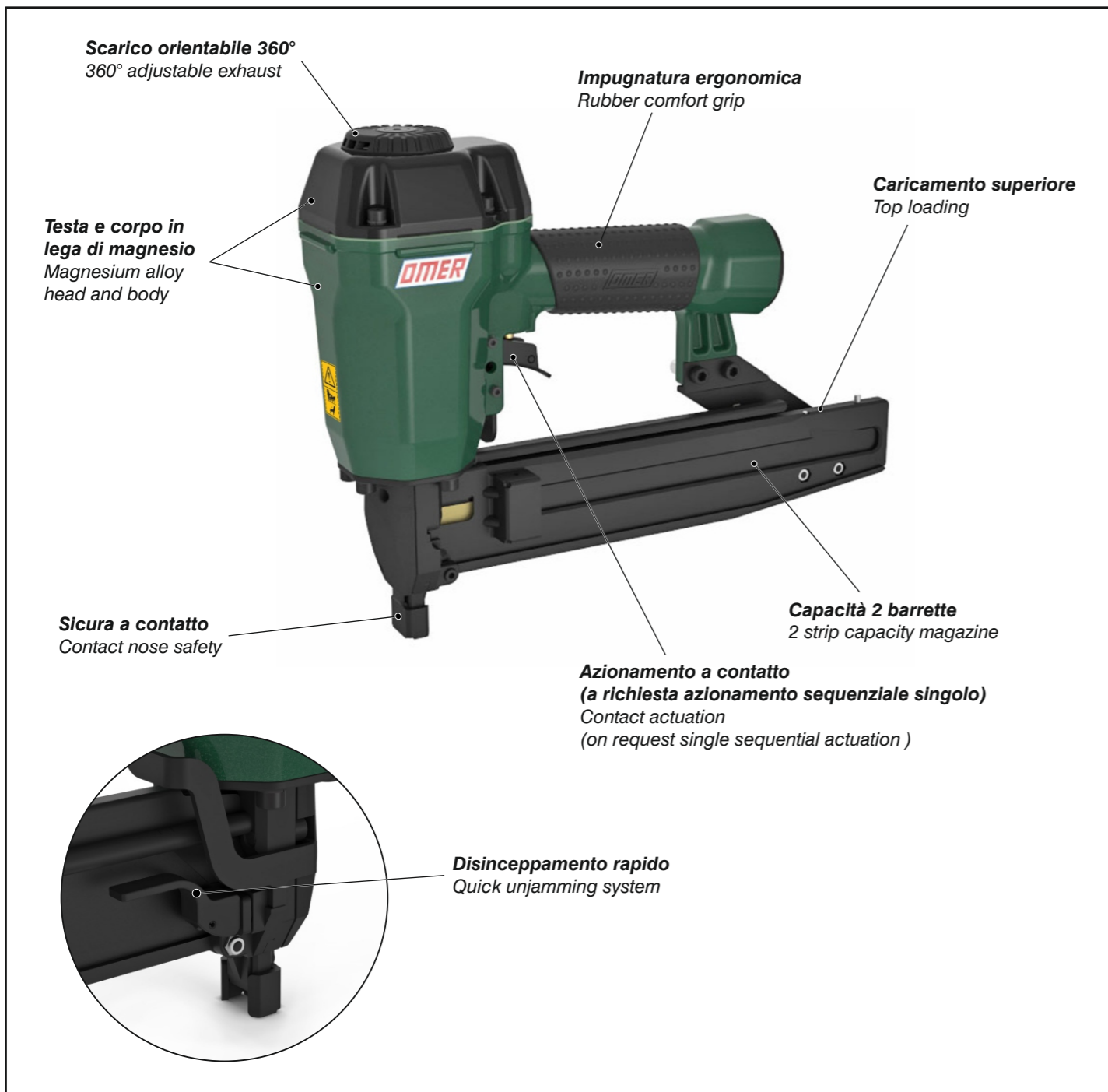

Manuale d'uso, manutenzione e parti di ricambio
Use, maintenance and spare parts manual
Gebrauchsanweisung, Instandhaltungsrichtlinien und Ersatzteile
Manuel d'utilisation, entretien et pièces de rechange
Manual de uso, mantenimiento y repuestos
Εγχειρίδιο χρήσης, συντήρησης και ανταλλακτικών
Manual de utilização, manutenção e partes sobresselentes
Handleiding voor gebruik, onderhoud en wisselstukken
Brugsanvisning, vedligeholdelse og reservedelsliste

Parte 2
Part 2
Teil 2
Partie 2
Part 2
2° Μερὸς
Parte 2
Deel 2
Del 2



1016.50

cod. 1858600

1858600_101650_5_090320_FL



Warning: Please read the instructions and warnings for this tool carefully before use. Failure to do so could lead to serious injury.

Dati tecnici Technical data Technische daten	Données techniques Datos técnicos Τεχνικά χαρακτηριστικά	Dados técnicos Technische gegevens Teknische data	
Misure impiegabili mm Usable lengths mm Gebrauchliche Längen mm	Mesures utilisables mm Medidas que se pueden emplear mm Διαστάσεις σε μμ	Medidas que se podem utilizar mm Te gebruiken lengtes in mm Brugbare længder i mm	20 ÷ 50
Capacità caricatore n° punti Magazine capacity No. of fasteners Magazinkapazität Nägel	Capacité chargeur n° de points Capacidad cargador n° puntos Δυνατότητα γεμιστέρα, σπινδύτερος	Capacidade carregador n° pontos Capaciteit magazijn in aantal spijkers Kapacitet af magasin antal klemme	145
Pressione d'esercizio Working pressure Betriebsdruck	Pression de fonctionnement Presión de trabajo Πίεση λειτουργίας ατμ.	Pressao de trabalho Werkdruk Arbejds tryk bar	5 ÷ 7,5 bar 70 ÷ 105 psi
Consumo aria litri/colpo Air consumption litres/shot Luftverbrauch Liter/Schlag	Consommation air litre/coup Consumo aire-litros/golpe Κατανοση αερα λ/ξτπημα	Consumo ar litro/golpe Luchtverbruik liter/schot Luftforbrug liter/skud	1,22
Peso kg Weight kg Gewicht kg	Poids kg Peso kg Βαρος κγ	Peso kg Gewicht in kg Vaegt kg	2,24
Dimensioni (AxBxH) mm Dimensions mm Größe mm	Dimension mm Dimensiones mm Δυνατότητα γεμιστέρα, σπινδύτερος	Dimencoes mm Afmetingen in mm Dimensioner mm	352x91x263

EN 12549 :1999 ISO 11201 :1995		
Pressione sonora in pos. operatore Sound pressure at the workstation Lärmintensität am Arbeitsplatz	Pression acoustique près de l'opérateur Presión sonora en posición encargado Ακουστική πίεση στη θέση χειριστού	Intensidade sonora perto do operador Geluidssterkte op de werkplek Lydstyrke på operatorposten
		$L_{pA, 1s}$ (Rif. 20μPa) 86,7 dB(A)

EN 12549 :1999 ISO 3744 :1994		
Potenza sonora emessa Emitted sound power Ausgestrahlte Lärmintensität	Puissance acoustique émise Potencia sonora emitida Ακουστική ισχυ	Potência sonora emitida Uitgestraalde geluidssterkte Udsendt lydstyrke
		$L_{WA, 1s}$ (Rif. 1pW) 97,9 dB(A)

EN 28662 :1992 ISO 5349 :1986 ISO 8662 -11		
Valore medio ponderato di vibrazione sull'impugnatura Weighted mean value of vibration on the grip Mitteler Vibrationswert, am Griff gemessen	Valeur moyenne pondérée de vibration mesurée sur la poignée Valor medio ponderado de vibracion medida en la empunadura Μεσος ορος μετρησις κραδασιμον στη χειρολαβη	Valor medio ponderado de vibracao medido no punho Gewogen gemiddelde vibratiewaarde Middelvaerdi af vibrationer på handtaget
		Bump $a_{h,w}$ 4,75 m/s²

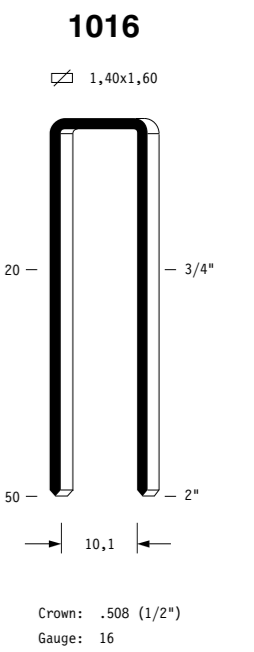

Disinceppamento - Jam clearing

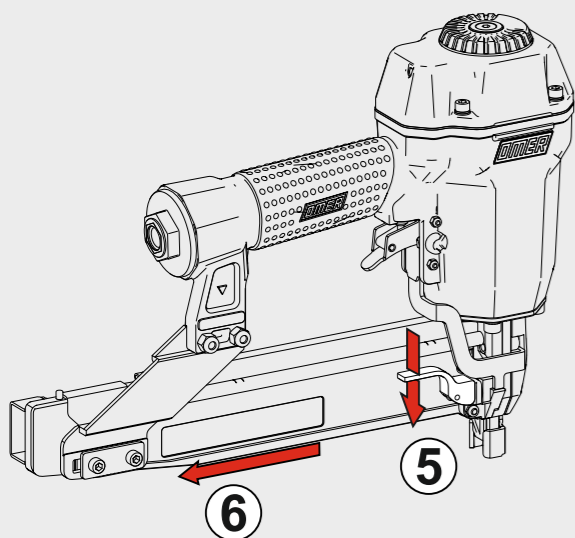
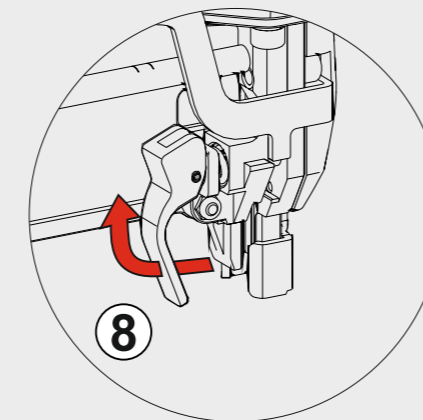
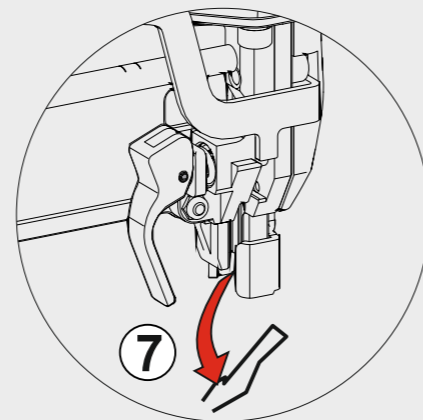
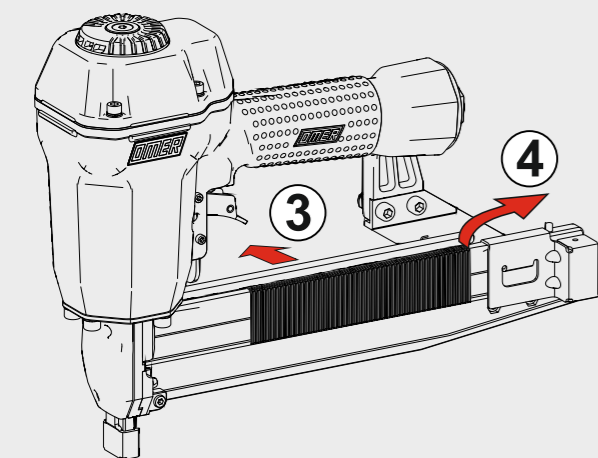
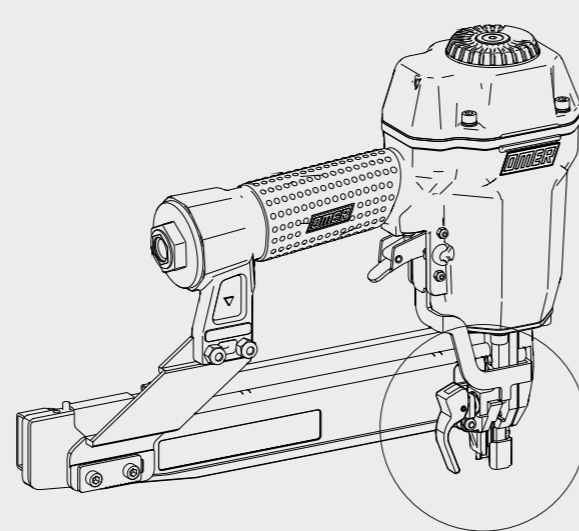
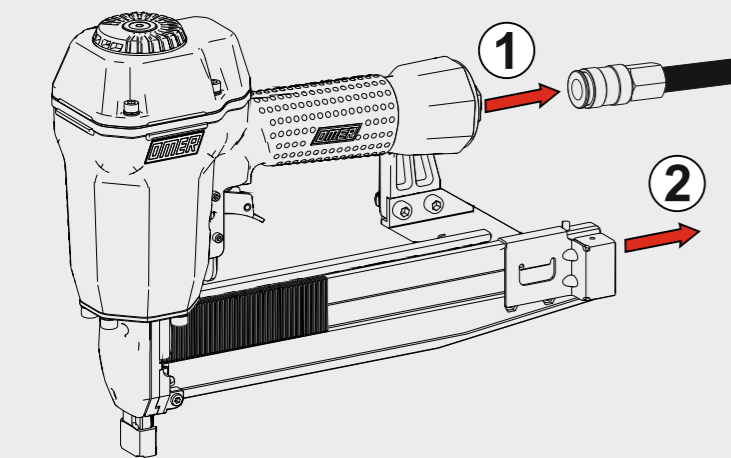

Parti di ricambio - Spare parts - Ersatzteile - Pièces de rechange - Piezas de repuesto Ανταλλακτικά - Partes sobresselentes - Wisselstukken - Reservedele

Cod.	Descrizione	Description
00.11	O-Ring	O-Ring
00.13	O-Ring	O-Ring
00.14	O-Ring	O-Ring
00.15.2	O-Ring	O-Ring
00.21	O-Ring	O-Ring
00.48	O-Ring	O-Ring
00.54	O-Ring	O-Ring
01.46	O-Ring	O-Ring
01.53	O-Ring	O-Ring
01.57	O-Ring	O-Ring
01.75	O-Ring	O-Ring
02.45	O-Ring	O-Ring
02.48	O-Ring	O-Ring
03.00	Dado	Nut
03.04.5	Vite	Screw
03.31	Vite	Screw
04.00	Dado	Nut
04.26	Vite	Screw
05.00	Dado	Nut
05.20	Vite	Screw
05.25	Vite	Screw
06.00.2	Dado	Nut
06.10.5	Vite	Screw
06.14	Vite	Screw
06.20	Vite	Screw
06.25.2	Vite	Screw
07.25	Chiave esagonale	Hex. bar wrench
07.30	Chiave esagonale	Hex. bar wrench
07.40	Chiave esagonale	Hex. bar wrench
07.50	Chiave esagonale	Hex. bar wrench
09.15	Rondella	Washer
09.16	Rondella	Washer
09.21	Anello elastico	Elastic ring
10.55	O-Ring	O-Ring
13.14.2	Spina	Pin
17.27	Tappo	Inlet cap
21.85	Corpo	Body
22.85	Testa	Head
25.81	Deflettore	Deflector
26.85	Cilindro	Cylinder
27.85	Anello cilindro	Cylinder ring
28.81	Guarnizione testa	Head gasket
30.85	Pistone	Piston
32.85	Ammortizzatore	Bumper
40.85	Valvola completa	Valve ass'y
43.12.7	Rondella	Washer
44.84	Guarnizione cilindro	Cylinder gasket
44.85	Ammortizzatore	Bumper
45.85	Distanziale	Spacer
50.85	Pulsante completo	Trigger valve ass'y
51.85	Boccola pulsante	Trigger valve housing
53.85	Pistone servovalvola	Valve piston
54.83	Pulsante	Trigger valve
55.85	Raccordo pulsante	Bush
64.82	Carter	Hold down
64.85	Carter sicura	Safety Guard
71.86	Reggicaricatore	Support
73.81	Perno	Pin
73.82	Perno	Pin
75.85	Sicura	Safety
77.81	Guida sicura	Safety guide
80.85	Leva	Lever
81.83	Grilletto comando	Trigger
83.80	Rondella	Washer
83.81	Piastrina	Plate
83.82	Piastrina	Plate
86.80	Boccola	Bush
90.83	Molla	Spring
91.21	Molla	Spring
91.84	Molla	Spring
91.85	Molla	Spring
91.86	Molla	Spring
92.80	Molla	Spring
93.81	Molla	Spring
23.80.75	Battente	Driver
52.80.74	Caricatore	Magazine
62.80.74	Nasello	Nose
72.80.74	Spingipunto	Pusher
81.80.00	Flangia	Flange
92.80.75	Testina	Nose plate
D01	Bocchetta olio	Oiler
D02	Occhiali protettivi	Protective goggles

Guarnizioni - O-Rings - Dichtungen - Joints - Kit O-Rings - Αασταγγακία - Kit O-Rings - Pakninger

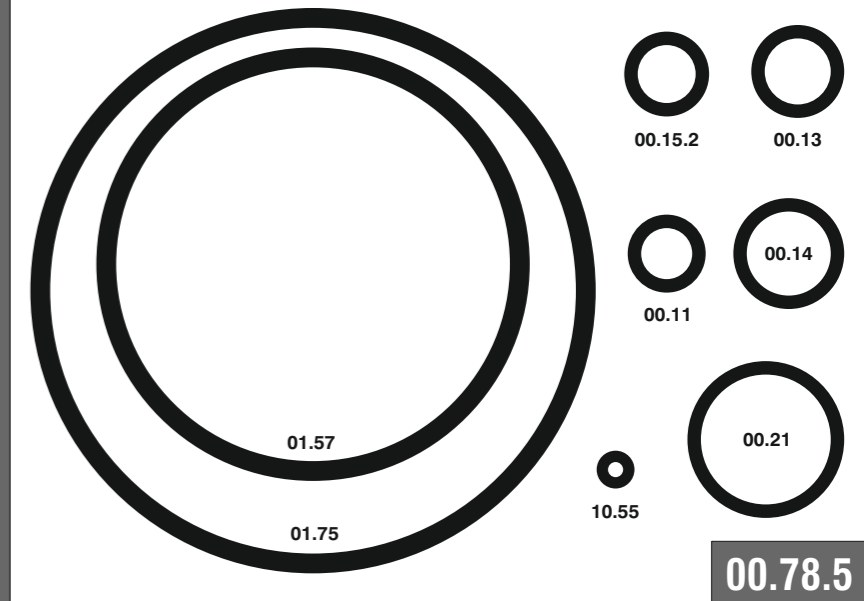
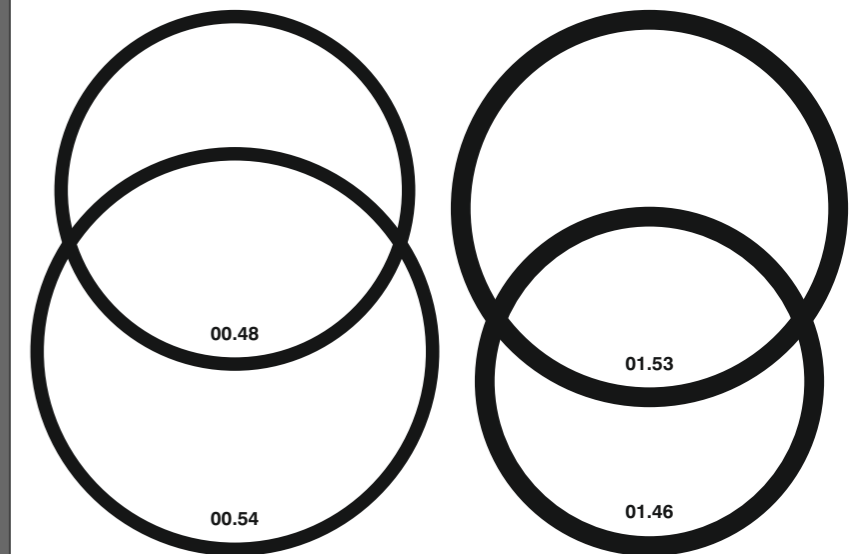
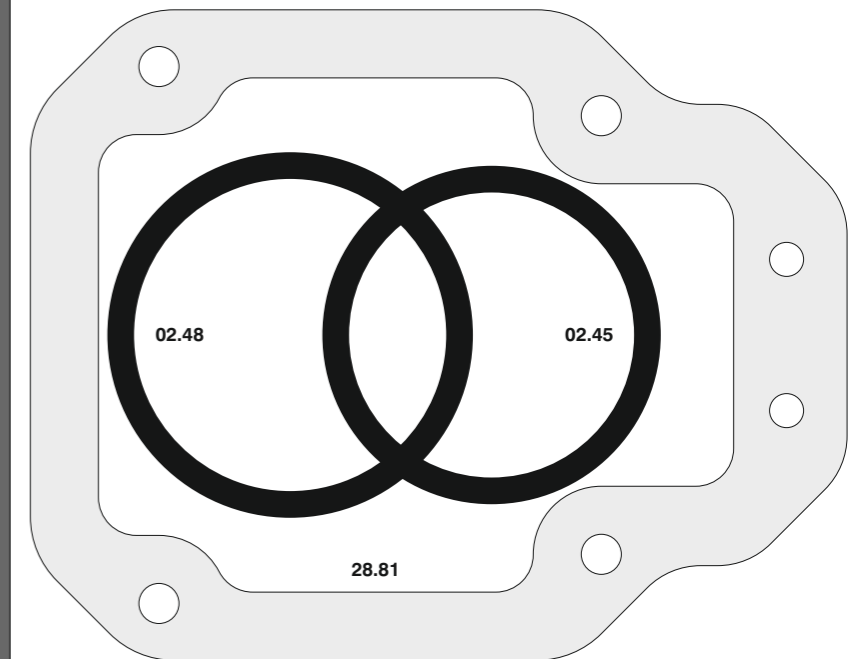

1016.50

cod. 1858600

Indice di modifica
Upgrade number

5

Azionamento - Actuation

Azionamento a contatto
Contact actuation

81.83

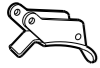

Di serie / Standard

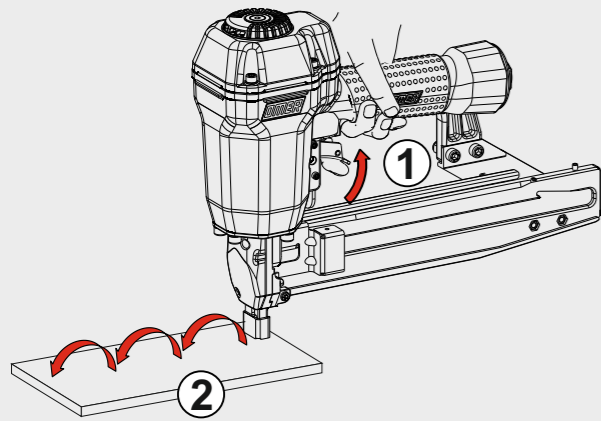

Oppure - Or

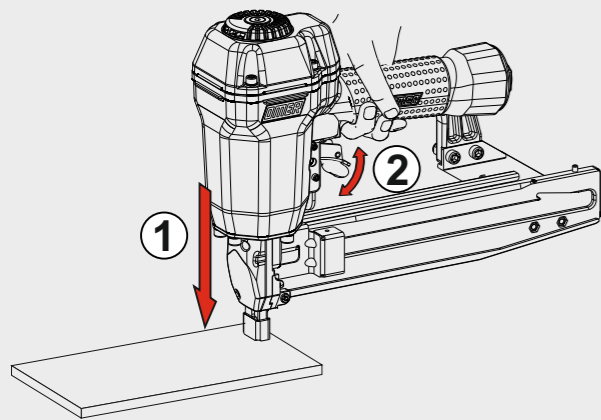

Azionamento sequenziale singolo
Single sequential actuation

81.83.1

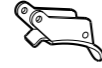

A richiesta / On request

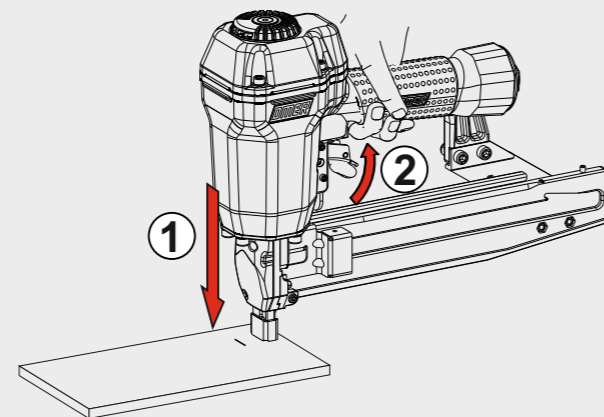
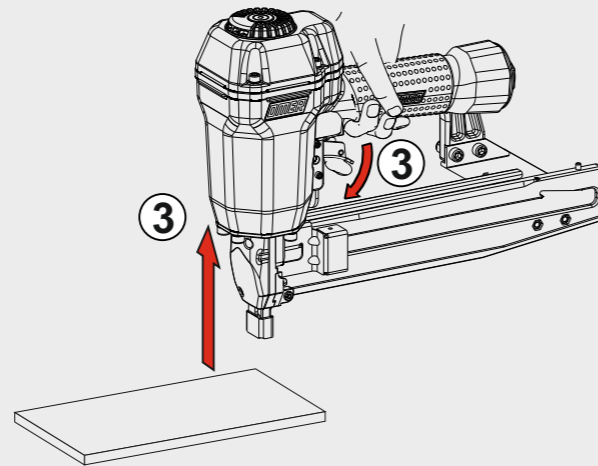
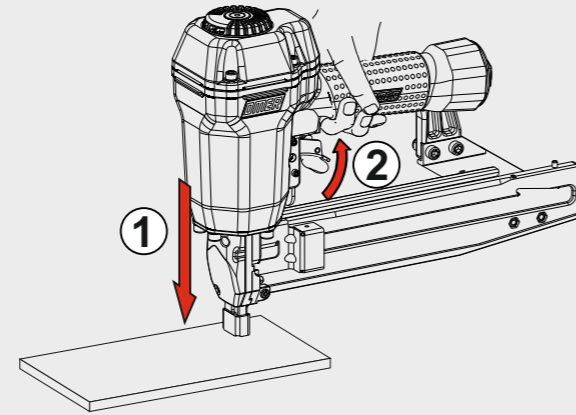

Caricamento - Loading

