

**Azionamento singolo con doppia attivazione**

Single actuation with dual activation

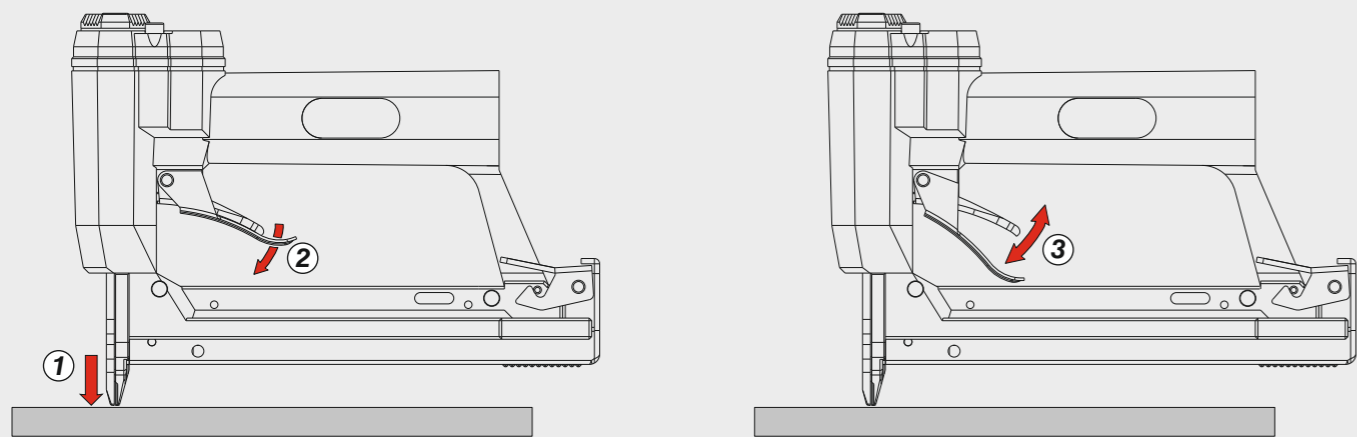

Manuale d'uso, manutenzione e parti di ricambio	Parte 2
Manual for use, maintenance and spare parts	Part 2
Bedienungs- und Wartungshandbuch sowie Ersatzteilliste	Teil 2
Mode d'emploi, de maintenance et pièces de rechange	Partie 2
Manual de uso, mantenimiento y recambios	Part 2
Εγχειρίδιο χρήσης, συντήρησης και ανταλλακτικών	Μέρος 2
Manual de uso, manutenção e peças sobresselentes	Parte 2
Handleiding voor gebruik, onderhoud en wisselstukken	Deel 2
Kullanım, bakım ve yedek parça kılavuzu	Kısım 2
Användar-, underhålls- och reservdelshandbok	Del 2



**P.7**

cod. 10802200

Caricamento - Loading - Laden - Chargement - Carga - Γέμισμα - Carregamento - Laden - Yükleme - Laddning

**Caricamento da sotto**

Bottom load magazine

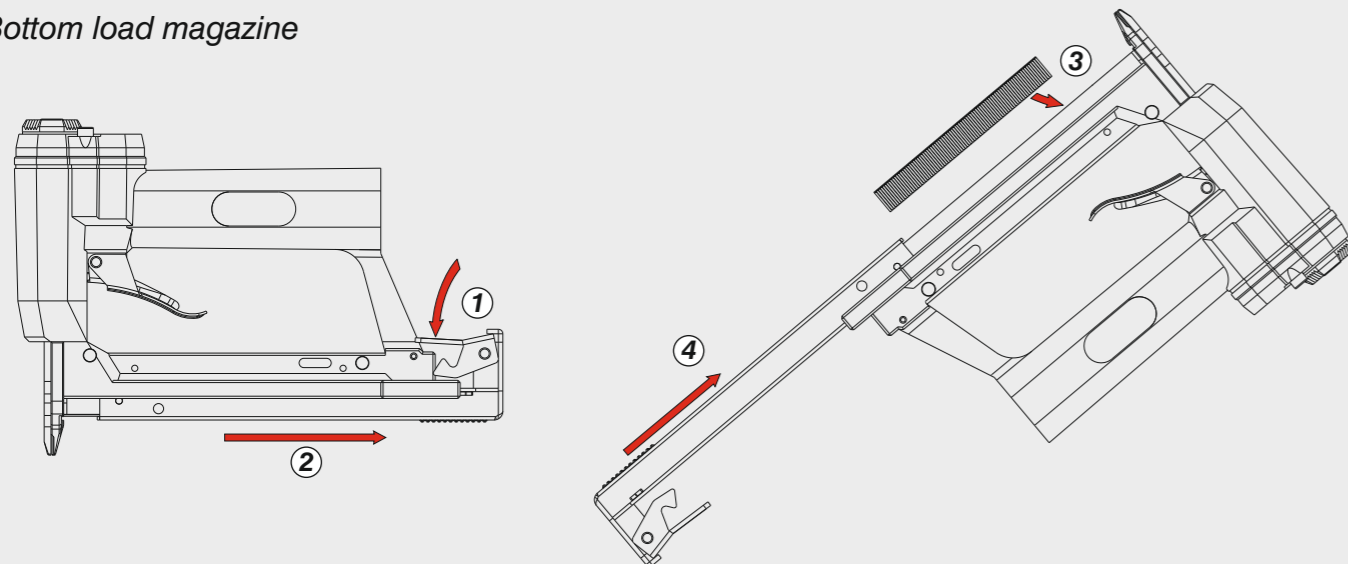

Caratteristiche - Features - Merkmale - Caractéristiques - Características  
 Χαρακτηριστικά - Características - Kenmerken - Özellikler - Funktionen

**Scarico orientabile a 360°**

360° adjustable exhaust

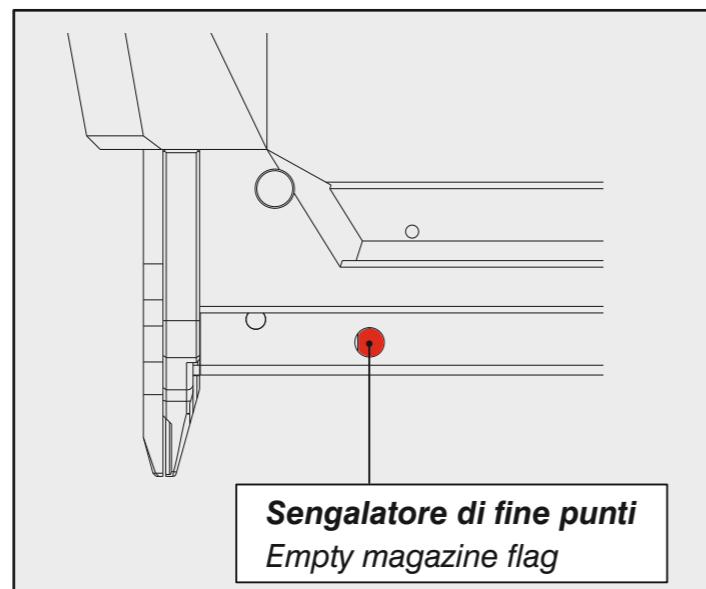
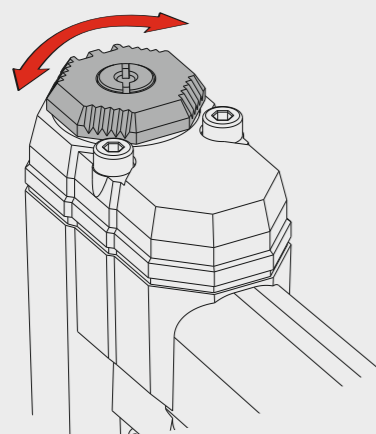

**Sengalatore di fine punti**  
 Empty magazine flag



Dati tecnici Technical data Technische Daten Tekniska data	Caractéristiques techniques Datos técnicos Τεχνικά χαρακτηριστικά	Dados técnicos Technische gegevens Teknik veriler		
<b>Misure impiegabili</b> Lengths Verwendbare Nagellänge Dimensioner som kan användas	Dimensions utiles Medidas de longitud Μήκος Αναλωσίμου	Medidas utilizáveis Toepasbare afmetingen Boy	mm inch	<b>7 + 8</b> <b>9/32" + 5/16"</b>
<b>Capacità caricatore n° punti</b> Magazine capacity Magazinkapazität: Nägel Magasinkapacitet: Antal punkter	Capacité chargeur n° de points Capacidad cargador n° puntos Δυνατότητα γεμιστέρα	Capacidade carregador n° pontos Capaciteit magazijn in aantal spijkers Dergi kapasitesi		<b>200</b>
<b>Pressione d'esercizio</b> Operating pressure Betriebsdruck Drifttryck	Pression d'exercice Presión de servicio Πίεση λειτουργίας	Pressão de serviço Werkdruk Çalışma basıncı	bar psi	<b>4 + 6</b> <b>60 + 90</b>
<b>Consumo aria</b> Air consumption Luftverbrauch Luftförbrukning	Consommation d'air Consumo aire Κατανάλωση αέρα	Consumo ar Luchtverbruik Hava tüketimi	lt/colpo ft³/cycle	<b>0,10</b> <b>0,03531</b>
<b>Peso</b> Weight Gewicht Vikt	Poids Peso Βάρος	Peso Gewicht Ağırlık	kg lbs	<b>0,65</b> <b>1,43</b>
<b>Dimensioni</b> Dimensions Abmessungen Dimensioner (AxBxH)	Dimensions Διαστάσεις	Dimensões Afmetingen Boyutlar	mm inch	<b>200x33x148</b> <b>7-7/8"x1-5/16"x5-27/32"</b> (LxWxH)
<b>EN 12549 :2009 EN ISO 4871 :2009</b> <b>Pressione sonora in pos. operatore</b> Sound pressure in operator's position Schalldruck am Arbeitsplatz Ljudtryck på operatörsplatsen	Pression sonore poste Opérateur Presión sonora en la pos. del operador Ηχητική πίεση στη θέση του χειριστή	Pressão sonora na posição Operador Geluidsdruk op de werkplaats Operatör pozisyonunda ses basıncı	dB(A)	<b>75</b> (K = 4 dB)
<b>EN 12549 :2009 EN ISO 3746 :2011 EN ISO 4871 :2009</b> <b>Potenza sonora emessa</b> Sound power emitted Emitierte Schalleistung Avgiven ljudeffekt	Puissance sonore émise Potencia sonora emitida Εκπεμπόμενη ηχητική ισχύς	Potência sonora emitida Geëmitteerd geluidsvermogen Çıkan ses gücü (ses desibel)	dB(A)	<b>82</b> (K = 4 dB)
<b>CEN ISO/TS 8662-11 :2006 EN ISO 5349-2 :2004 EN 12096 :1999</b> <b>Emissione vibratoria sull'impugnatura</b> Vibratory emissions on handle Emisión de vibraciones en la empuñadura Vibrationsemission am Griff Vibrationsemission på handtaget	Émission vibratoire sur la prise en main Emisión de vibraciones en la empuñadura Εκπεμπόμενες δονήσεις στη λαβή	Emissão vibratória na empunhadura Trillingsemissie op de handgreep Tutamak üzerindeki vibrasyon emisyonları	m/s²	<b>&lt;2,5</b> (K = 2 m/s²)

**Tipo di punto**  
 Type of fastener  
 Befestigungsmittel  
 Type de rivet  
 Tipo de punto  
 Τύπος αναλωσίμου  
 Tipo de agrafa  
 Type nietjes  
 Zimba ve çivi tipleri  
 Typ av stygn

**Pins 6**  
 Ø 0,64  
  
 Wire dia: .025"  
 Gauge: 23

10802200\_P7\_8\_rev1\_27/05/2024 DV

Parti di ricambio - Spare parts - Ersatzteile - Pièces de rechange - Recambios  
Ανταλλακτικά - Partes sobresselentes - Wisselstukken - Yedek parçalar - Reservdelar

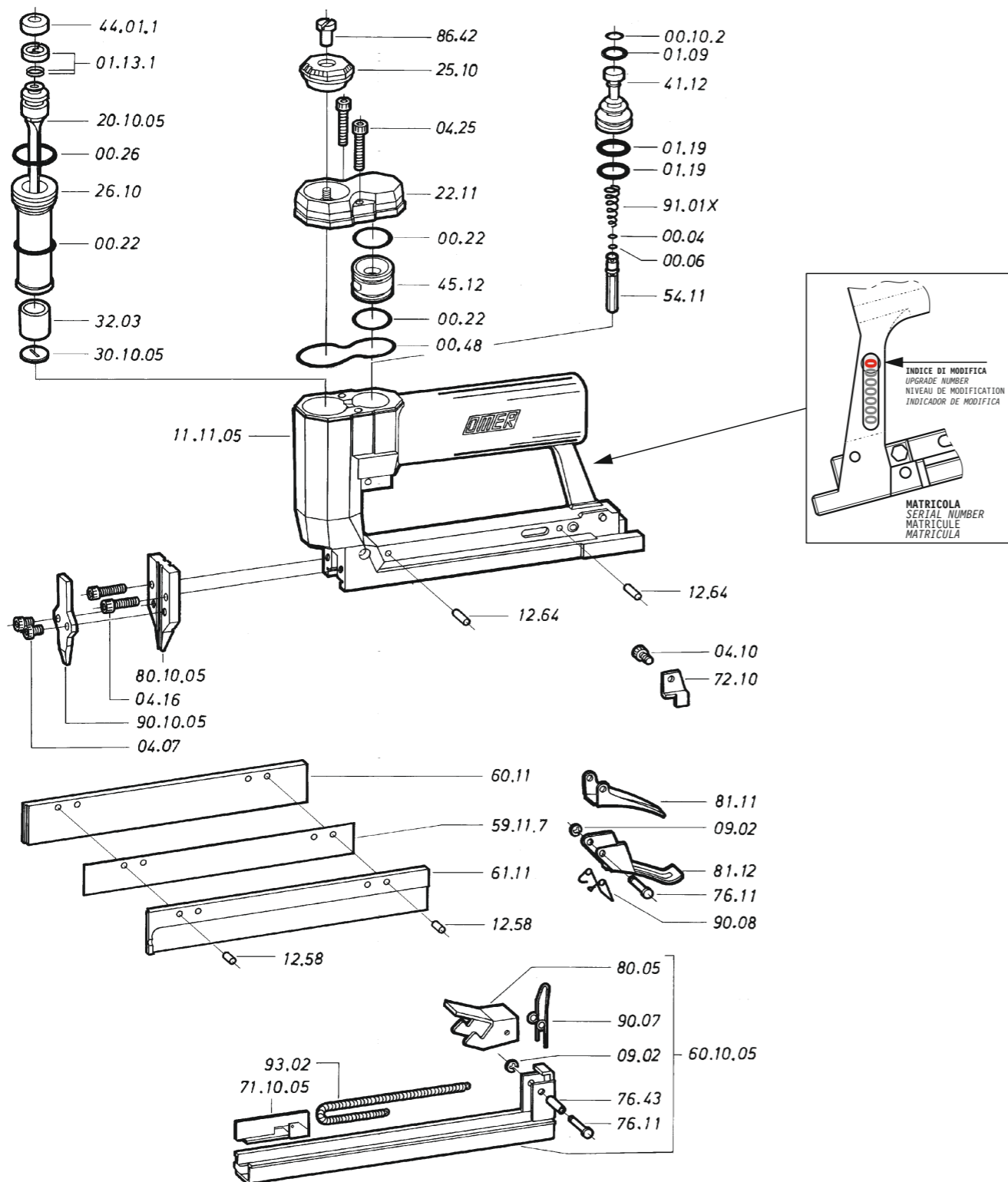

Dotazioni - Equipment - Ausstattung - Outillage - Dotaciones - Εξοπλισμός  
Dotações - Uitrusting - Donanimlar - Utrustning



**P.7**

cod. 10802200

Parti di ricambio - Spare parts - Ersatzteile - Pièces de rechange - Recambios  
Ανταλλακτικά - Partes sobresselentes - Wisselstukken - Yedek parçalar - Reservdelar

Cod.	Descrizione	Description
00.04	O-Ring	O-Ring
00.06	O-Ring	O-Ring
00.10.2	O-Ring	O-Ring
00.22	O-Ring	O-Ring
00.26	O-Ring	O-Ring
00.48	O-Ring	O-Ring
01.09	O-Ring	O-Ring
01.13.1	Guarnizione	Gasket
01.19	O-Ring	O-Ring
04.07	Vite	Screw
04.10	Vite	Screw
04.16	Vite	Screw
04.25	Vite	Screw
07.03	Sfera	Ball
07.30	Chiave esagonale	Hex. Bar wrench
09.02	Anello elastico	Elastic ring
12.58	Spina	Pin
12.64	Spina	Pin
22.11	Testa	Head
25.10	Deflettore	Exhaust deflector
26.10	Cilindro	Cylinder
32.03	Ammortizzatore	Bumper
41.12	Pistone valvola	Valve
44.01.1	Ammortizzatore	Bumper
45.12	Anello valvola	Ring
54.11	Pulsante	Trigger valve
59.11.7	Distanziale	Spacer
60.11	Guida Sx	Sx guide
61.11	Guida Dx	Dx guide
72.10	Fermo carrello	Slider stop
76.10	Perno	Pin
76.11	Perno	Pin
76.43	Perno	Pin
80.05	Grilletto chiusura	Trigger
81.11	Grilletto comando	Trigger
81.12	Controgrilletto	Safety
86.42	Vite deflettore	Deflector screw
90.07	Molla	Spring
90.08	Molla	Spring
91.01X	Molla	Spring
93.02	Molla	Spring
11.11.05	Corpo	Body
20.10.05	Battente	Driver
30.10.05	Rondella	Washer
60.10.05	Carrello	Slider
71.10.05	Spingipunto	Pusher
80.10.05	Controtestina	Nose
90.10.05	Testina	Nose plate

Guarnizioni - O-Rings - Dichtungen - Juntas - Δακτύλιος στεγανοποίησης - Vedantes - O-ringen - Contalar - O-ringar

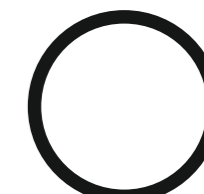
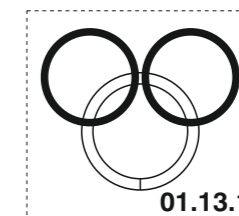

00.26

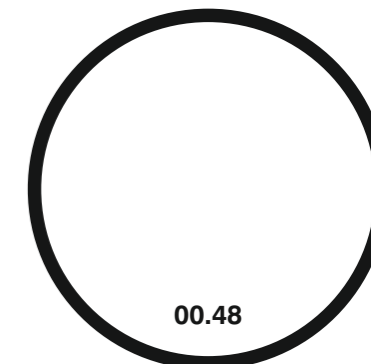

00.48

00.71.1

**P.7**

cod. 10802200

Indice di modifica  
Upgrade number

**8**

Disincceppamento - Jam clearing - Staubeseitigung - Décoincement - Desatascamiento - Απεμπλοκή  
Desencravamento - Deblokkering bij vastlopen - Sikişma giderme - Rensning av igensättningar

