

Azionamento singolo con doppia attivazione
 Single actuation with dual activation

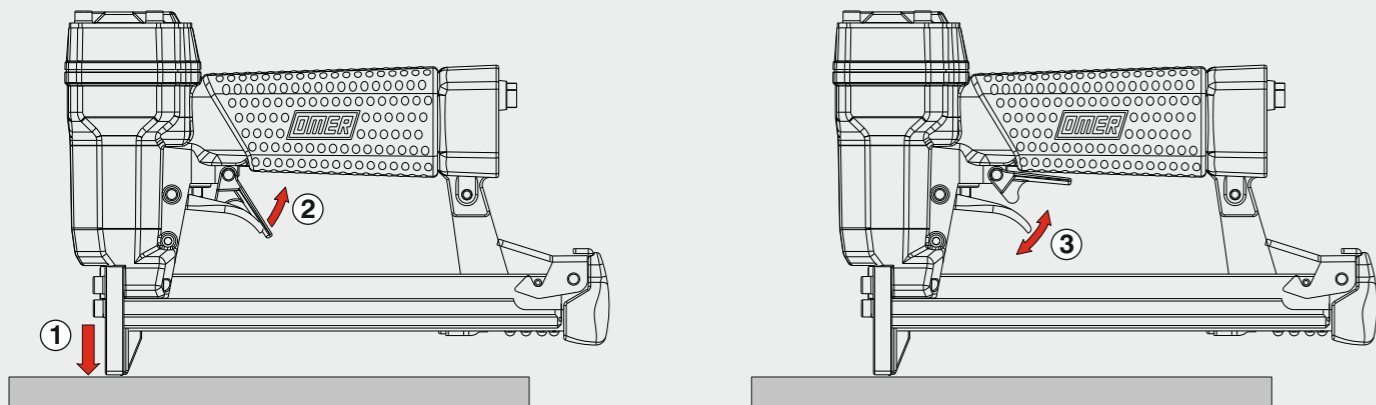

| | |
|---|-----------------|
| Manuale d'uso, manutenzione e parti di ricambio | Parte 2 |
| Manual for use, maintenance and spare parts | Part 2 |
| Bedienungs- und Wartungshandbuch sowie Ersatzteilliste | Teil 2 |
| Mode d'emploi, de maintenance et pièces de rechange | Partie 2 |
| Manual de uso, mantenimiento y recambios | Part 2 |
| Εγχειρίδιο χρήσης, συντήρησης και ανταλλακτικών | Μέρος 2 |
| Manual de uso, manutenção e peças sobresselentes | Parte 2 |
| Handleiding voor gebruik, onderhoud en wisselstukken | Deel 2 |
| Kullanım, bakım ve yedek parça kılavuzu | Kısım 2 |
| Användar-, underhålls- och reservdelshandbok | Del 2 |



62.16

cod. 1145200



Caricamento - Loading - Laden - Chargement - Carga - Γέμισμα - Carregamento - Laden - Yükleme - Laddning

Caricamento da sotto
 Bottom load magazine

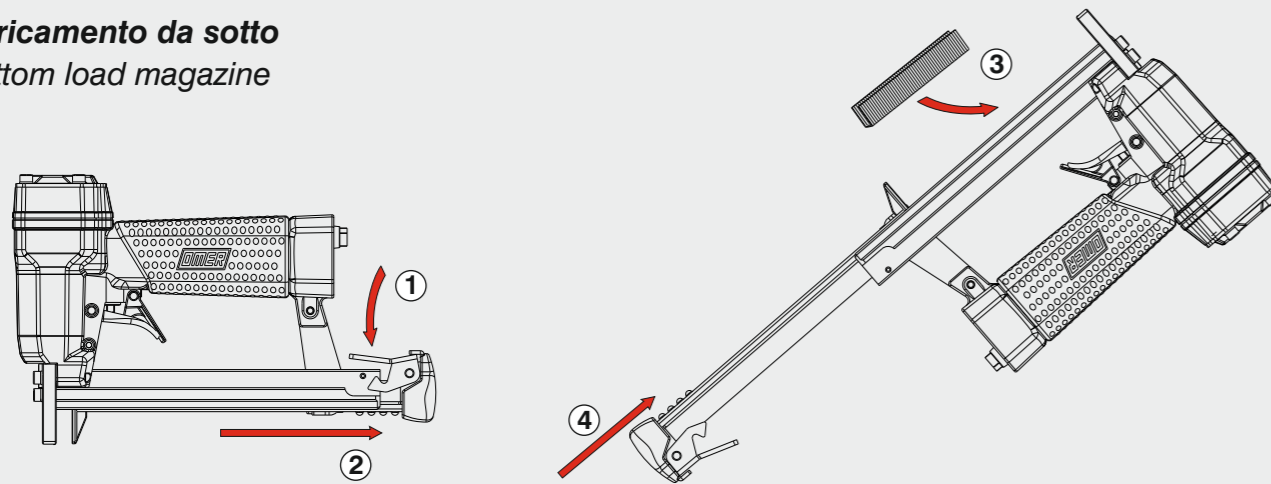

Disinzeppamento - Jam clearing - Staubeseitigung - Décoincement - Desatascamiento - Απεμπλοκή
 Desencravamento - Deblokkering bij vastlopen - Sıkışma giderme - Rensning av igensättningar

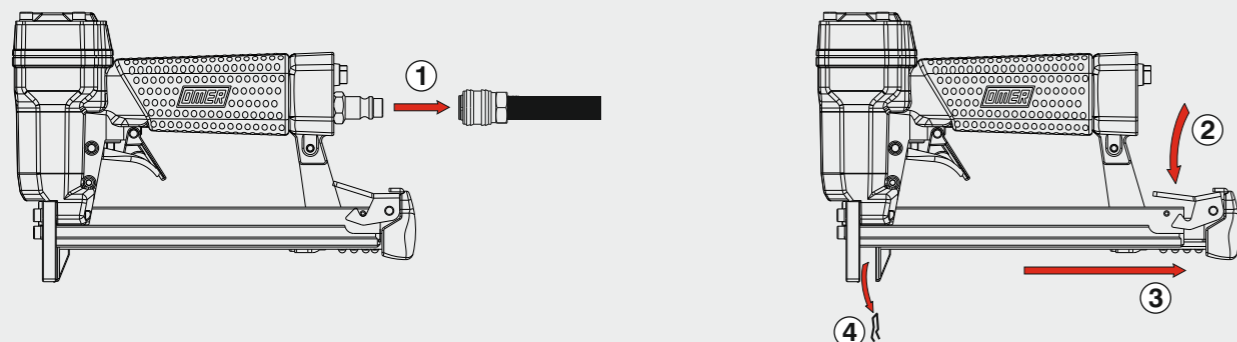

| | | |
|--|--|--|
| Dati tecnici Technical data Technische Daten Tekniska data | Caractéristiques techniques Datos técnicos Τεχνικά χαρακτηριστικά | Dados técnicos Technische gegevens Teknik veriler |
|--|--|--|

| | | | | |
|--|---|--|-------------------------------------|--|
| Misure impiegabili Lengths Verwendbare Nagellänge Dimensioner som kan användas | Dimensions utiles Medidas de longitud Μήκος Αναλωσίμου | Medidas utilizáveis Toepasbare afmetingen Boy | mm | 4 - 16 5/32" - 5/8" |
| Capacità caricatore n° punti Magazine capacity Magazinkapazität Nägel Magasinkapacitet Antal punkter | Capacité chargeur n° de points Capacidad cargador n° puntos Δυνατότητα γεμιστέρα | Capacidade carregador n° pontos Capaciteit magazijn in aantal spijkers Dergi kapasitesi | | 185 |
| Pressione d'esercizio Operating pressure Betriebsdruck Drifttryck | Pression d'exercice Presión de servicio Πίεση λειτουργίας | Pressão de serviço Werkdruk Çalışma basıncı | bar psi | 4 - 6 60 - 90 |
| Consumo aria Air consumption Luftverbrauch Luftförbrukning | Consommation d'air Consumo aire Κατανάλωση αέρα | Consumo ar Luchtverbruik Hava tüketimi | lt/colpo ft³/cycle | 0,13 0,00456 |
| Peso Weight Gewicht Vikt | Poids Peso Βάρος | Peso Gewicht Ağırlık | kg lbs | 0,90 1,98 |
| Dimensioni Dimensions Abmessungen Dimensioner (AxBxH) | Dimensions Dimensiones Διαστάσεις | Dimensões Afmetingen Boyutlar | mm inch | 223x43x148 8-25/32"x1-11/16"x5-13/16" (LxWxH) |

| | | | | | |
|--|--|--|--|-----------------------------|-------------------------------------|
| EN 12549 :2009 EN ISO 4871 :2009 | Pressione sonora in pos. operatore Sound pressure in operator's position Schalldruck am Arbeitsplatz Ljudtryck på operatörsplatsen | Pression sonore poste Opérateur Presión sonora en la pos. del operador Ηχητική πίεση στη θέση του χειριστή Operatör pozisyonunda ses basıncı | dB(A) | 81 (K = 4 dB) | |
| EN 12549 :2009 EN ISO 3746 :2011 EN ISO 4871 :2009 | Potenza sonora emessa Sound power emitted Emitierte Schalleistung Avgiven ljudeffekt | Puissance sonore émise Potencia sonora emitida Εκπεμπόμενη ηχητική ισχύς | Potência sonora emitida Geëmitteerd geluidsvermogen Çıkan ses gücü (ses desibeli) | dB(A) | 88 (K = 4 dB) |
| CEN ISO/TS 8662-11 :2006 EN ISO 5349-2 :2004 EN 12096 :1999 | Emissione vibratoria sull'impugnatura Vibratory emissions on handle Vibrationsemission am Griff Vibrationsemission på handtaget | Émission vibratoire sur la prise en main Emisión de vibraciones en la empuñadura Εκπεμπόμενες δονήσεις στη λαβή | Emissão vibratória na empunhadura Trillingsemissie op de handgreep Tutamak üzerinde vibrasyon emisyonları | m/s² | <2,50 (K = 2 m/s²) |

Tipo di punto
Type of fastener
Befestigungsmittel
Tipo de rivet
Tipo de punto
Τύπος αναλωσίμου
Type of nail
Zimba ve çivi tipleri
Typ av stygn

62

0,55x0,75

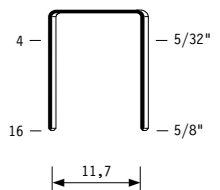

Crown: .500" (1/2")
 Gauge: 23

1145200_6216_6_rev21_27/06/2024_DV

Parti di ricambio - Spare parts - Ersatzteile - Pièces de rechange - Recambios
Ανταλλακτικά - Partes sobresselentes - Wisselstukken - Yedek parçalar - Reservdelar

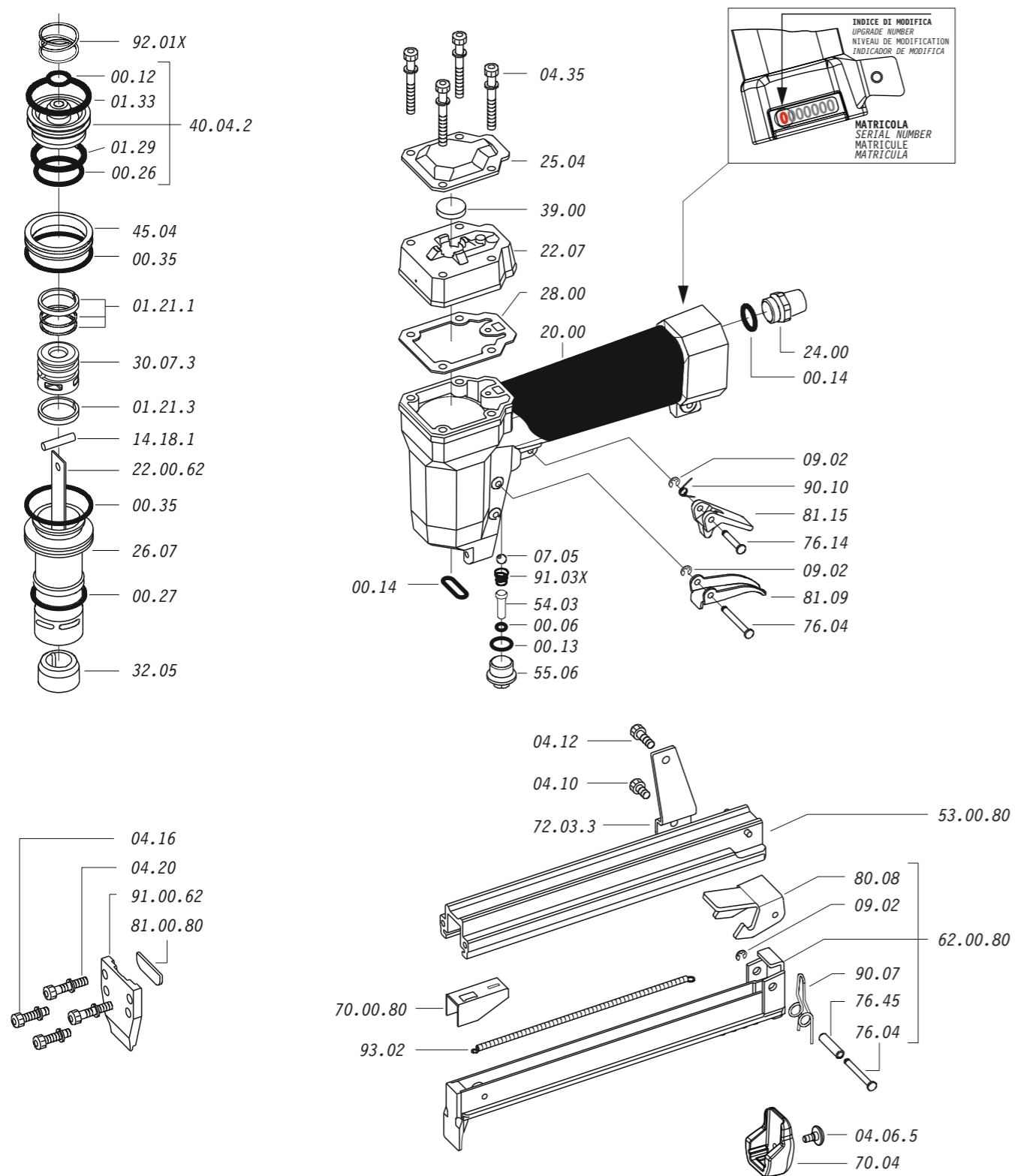

Dotazioni - Equipment - Ausstattung - Outillage - Dotaciones - Εξοπλισμός
Dotações - Uitrusting - Donanimlar - Utrustning

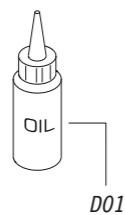

62.16

cod. 1145200

Parti di ricambio - Spare parts - Ersatzteile - Pièces de rechange - Recambios
Ανταλλακτικά - Partes sobresselentes - Wisselstukken - Yedek parçalar - Reservdelar

| Cod. | Descrizione | Description |
|----------|---------------------|-------------------|
| 00.06 | O-Ring | O-Ring |
| 00.12 | O-Ring | O-Ring |
| 00.13 | O-Ring | O-Ring |
| 00.14 | O-Ring | O-Ring |
| 00.26 | O-Ring | O-Ring |
| 00.27 | O-Ring | O-Ring |
| 00.35 | O-Ring | O-Ring |
| 01.21.1 | Guarnizione | Gasket |
| 01.21.3 | Guarnizione | Gasket |
| 01.29 | O-Ring | O-Ring |
| 01.33 | O-Ring | O-Ring |
| 04.06.5 | Vite | Screw |
| 04.10 | Vite | Screw |
| 04.12 | Vite | Screw |
| 04.16 | Vite | Screw |
| 04.20 | Vite | Screw |
| 04.35 | Vite | Screw |
| 07.05 | Sfera | Ball |
| 07.30 | Chiave esagonale | Hex. bar wrench |
| 09.02 | Anello elastico | Elastic ring |
| 14.18.1 | Spina | Pin |
| 20.00 | Corpo | Body |
| 22.07 | Testa | Head |
| 24.00 | Silenziatore | Silencer |
| 25.04 | Deflettore | Exhaust deflector |
| 26.07 | Cilindro | Cylinder |
| 28.00 | Guarnizione | Gasket |
| 30.07.3 | Pistone | Piston |
| 32.05 | Ammortizzatore | Bumper |
| 39.00 | Guarnizione scarico | Exhaust gasket |
| 40.04.2 | Valvola completa | Valve ass'y |
| 45.04 | Anello valvola | Ring |
| 54.03 | Pulsante | Trigger valve |
| 55.06 | Raccordo | Bush |
| 70.04 | Protezione | Guard |
| 72.03.3 | Reggicaricatore | Support |
| 76.04 | Perno | Pin |
| 76.14 | Perno | Pin |
| 76.45 | Perno molla | Pin |
| 80.08 | Grilletto chiusura | Trigger |
| 81.09 | Grilletto comando | Trigger |
| 81.15 | Controgrilletto | Safety |
| 90.07 | Molla | Spring |
| 90.10 | Molla | Spring |
| 91.03X | Molla | Spring |
| 92.01X | Molla | Spring |
| 93.02 | Molla | Spring |
| 22.00.62 | Battente | Driver |
| 53.00.80 | Caricatore | Magazine |
| 62.00.80 | Carrello | Slider |
| 70.00.80 | Spingipunto | Pusher |
| 81.00.80 | Controtestina | Nose |
| 91.00.62 | Testina | Nose plate |
| D01 | Bocchetta olio | Oiler |

Guarnizioni - O-Rings - Dichtungen - Joints toriques - Juntas - Δακτύλιος στεγανοποίησης - Vedantes - O-ringen - Contalar - O-ringar

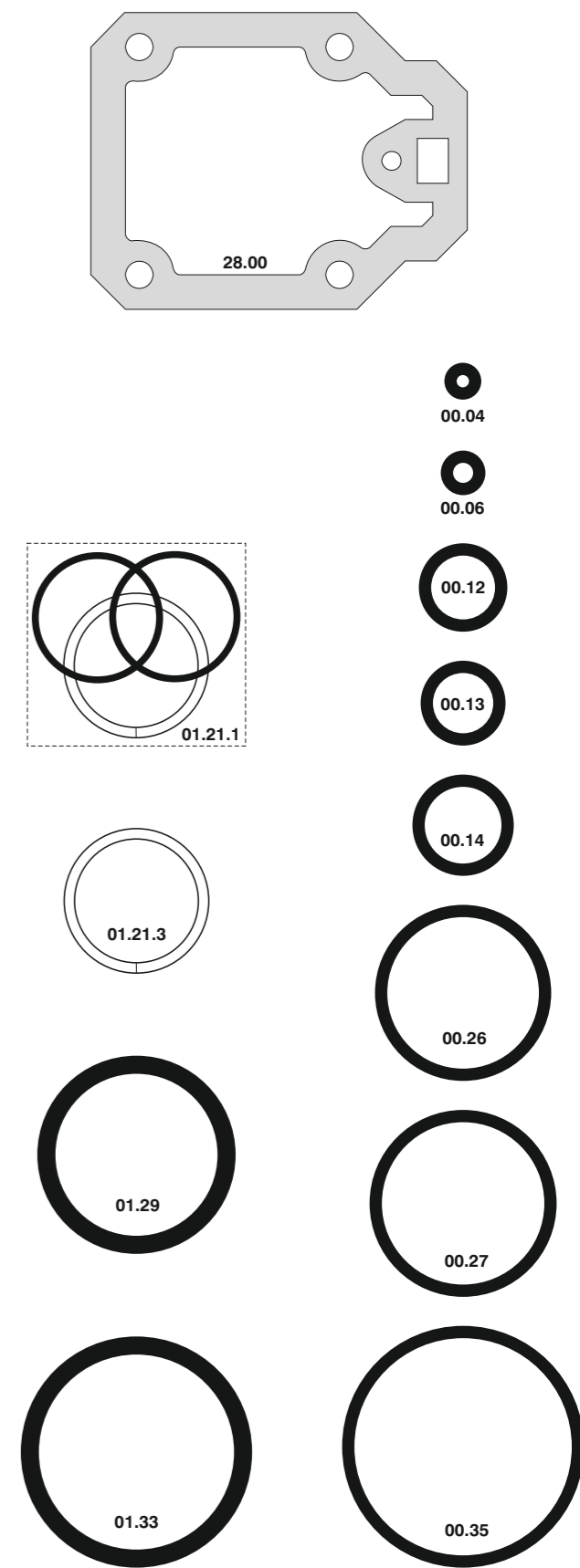

00.70.5

62.16

cod. 1145200

Indice di modifica
Upgrade number

6