

**Azionamento singolo con doppia attivazione**  
 Single actuation with dual activation

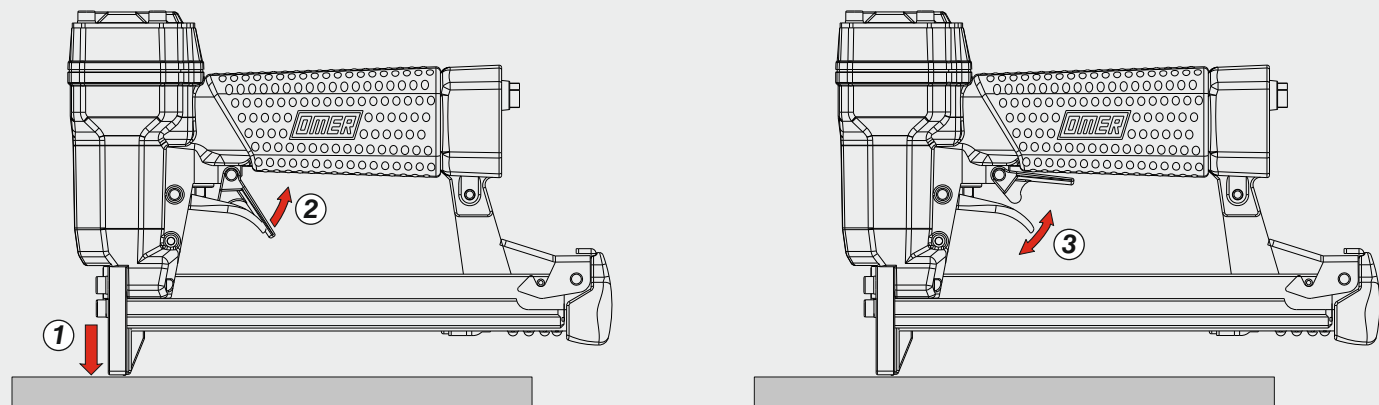

<b>Manuale d'uso, manutenzione e parti di ricambio</b>	<b>Parte 2</b>
<b>Manual for use, maintenance and spare parts</b>	<b>Part 2</b>
<b>Bedienungs- und Wartungshandbuch sowie Ersatzteilliste</b>	<b>Teil 2</b>
<b>Mode d'emploi, de maintenance et pièces de rechange</b>	<b>Partie 2</b>
<b>Manual de uso, mantenimiento y recambios</b>	<b>Part 2</b>
<b>Εγχειρίδιο χρήσης, συντήρησης και ανταλλακτικών</b>	<b>Μέρος 2</b>
<b>Manual de uso, manutenção e peças sobresselentes</b>	<b>Parte 2</b>
<b>Handleiding voor gebruik, onderhoud en wisselstukken</b>	<b>Deel 2</b>
<b>Kullanım, bakım ve yedek parça kılavuzu</b>	<b>Kısım 2</b>
<b>Användar-, underhålls- och reservdelshandbok</b>	<b>Del 2</b>



**64.16 SLNF**

cod. 1145440NF



**Caricamento - Loading - Laden - Chargement - Carga - Γέμισμα - Carregamento - Laden - Yükleme - Laddning**

**Caricamento da sotto**  
 Bottom load magazine

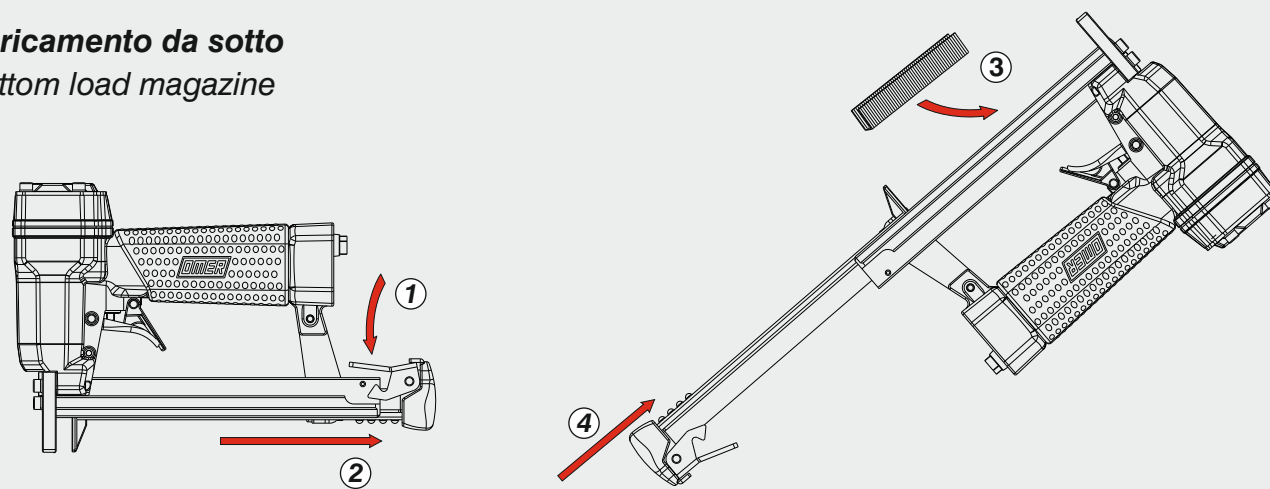

**Disincerramento - Jam clearing - Staubeseitigung - Décoincement - Desatascamiento - Απεμπλοκή**  
 Desencravamento - Deblokkering bij vastlopen - Sıkışma giderme - Rensning av igensättningar

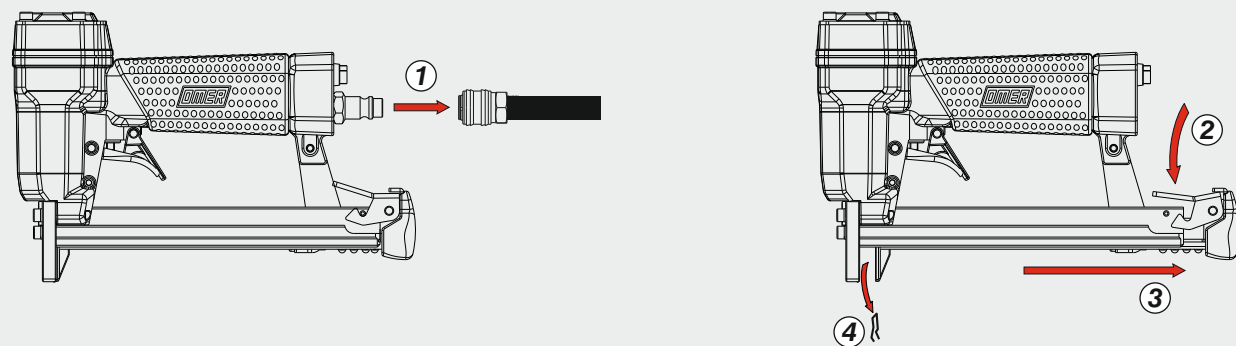

<b>Dati tecnici</b> Technical data Technische Daten Tekniska data	<b>Caractéristiques techniques</b> Datos técnicos Τεχνικά χαρακτηριστικά	<b>Dados técnicos</b> Technische gegevens Teknik veriler
--	--	--

<b>Misure impiegabili</b> Lengths Verwendbare Nagellänge Dimensioner som kan användas	<b>Dimensions utiles</b> Medidas de longitud Μήκος Αναλωσίμου	<b>Medidas utilizáveis</b> Toepasbare afmetingen Boy	<b>mm</b>	<b>4 - 16</b>
			<b>inch</b>	<b>5/32" - 5/8"</b>

<b>Capacità caricatore n° punti</b> Magazine capacity Magazinkapazität Magasinkapacitet	<b>Capacité chargeur n° de points</b> Capacidad cargador n° puntos Δυνατότητα γεμιστέρα	<b>Capacidade carregador n° pontos</b> Capaciteit magazijn in aantal spijkers Dergi kapasitesi	<b>mm</b>	<b>185</b>
--	---	--	-----------	------------

<b>Pressione d'esercizio</b> Operating pressure Betriebsdruck Drifttryck	<b>Pression d'exercice</b> Presión de servicio Πίεση λειτουργίας	<b>Pressão de serviço</b> Werkdruk Çalışma basıncı	<b>bar</b>	<b>4 - 6</b>
			<b>psi</b>	<b>60 - 90</b>

<b>Consumo aria</b> Air consumption Luftverbrauch Luftförbrukning	<b>Consommation d'air</b> Consumo aire Κατανάλωση αέρα	<b>Consumo ar</b> Luchtverbruik Hava tüketimi	<b>lt/colpo</b> <b>ft³/cycle</b>	<b>0,18</b> <b>0,00631</b>
--	--	---	-------------------------------------	-------------------------------

<b>Peso</b> Weight Gewicht Vikt	<b>Poids</b> Peso Βάρος	<b>Peso</b> Gewicht Ağırlık	<b>kg</b>	<b>1,00</b>
			<b>lbs</b>	<b>2,20</b>

<b>Dimensioni</b> Dimensions Abmessungen Dimensioner (AxBxH)	<b>Dimensions</b> Dimensiones Διαστάσεις	<b>Dimensões</b> Afmetingen Boyutlar	<b>mm</b>	<b>223x43x198</b>
			<b>inch</b>	<b>8-25/32"x1-11/16"x7-13/16"</b>
				(LxWxH)

<b>EN 12549 :2009 EN ISO 4871 :2009</b>	<b>Pressione sonora in pos. operatore</b> Sound pressure in operator's position Schalldruck am Arbeitsplatz Ljudtryck på operatörsplatsen	<b>Pression sonore poste Opérateur</b> Presión sonora en la pos. del operador Ηχητική πίεση στη θέση του χειριστή Operatör pozisyonunda ses basıncı	<b>dB(A)</b>	<b>81</b>
				(K = 4 dB)

<b>EN 12549 :2009 EN ISO 3746 :2011 EN ISO 4871 :2009</b>	<b>Potenza sonora emessa</b> Sound power emitted Emitierte Schalleistung Avgiven ljud effekt	<b>Puissance sonore émise</b> Potencia sonora emitida Εκπεμπόμενη ηχητική ισχύς	<b>Potência sonora emitida</b> Geëmitteerd geluidsvermogen Çıkan ses gücü (ses desibel)	<b>dB(A)</b>	<b>88</b>
					(K = 4 dB)

<b>CEN ISO/TS 8662-11 :2006 EN ISO 5349-2 :2004 EN 12096 :1999</b>	<b>Emissione vibratoria sull'impugnatura</b> Vibratory emissions on handle Vibrationsemission am Griff Vibrationsemission på handtaget	<b>Émission vibratoire sur la prise en main</b> Emisión de vibraciones en la empuñadura Εκπεμπόμενες δονήσεις στη λαβή	<b>Emissão vibratória na empunhadura</b> Trillingsemissie op de handgreep Tutamak üzerinde vibrasyon emisyonları	<b>m/s²</b>	<b>&lt;2,50</b>
					(K = 2 m/s²)

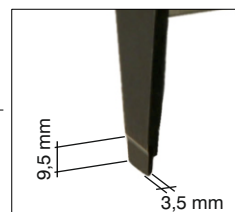
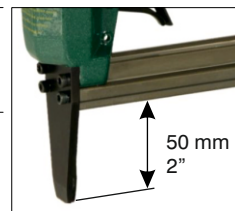

**Tipo di punto**  
Type of fastener  
Befestigungsmittel  
Type de rivet  
Tipo de punto  
Τύπος αναλωσίμου  
Tipo de agrafa  
Type nietjes  
Zimba ve çivi tipleri  
Typ av stygn

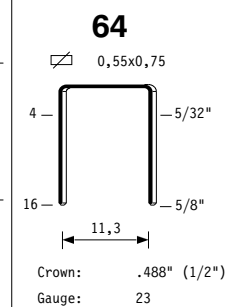

1145440NF\_6416SLNF\_4\_rev21\_28/06/2024\_DV

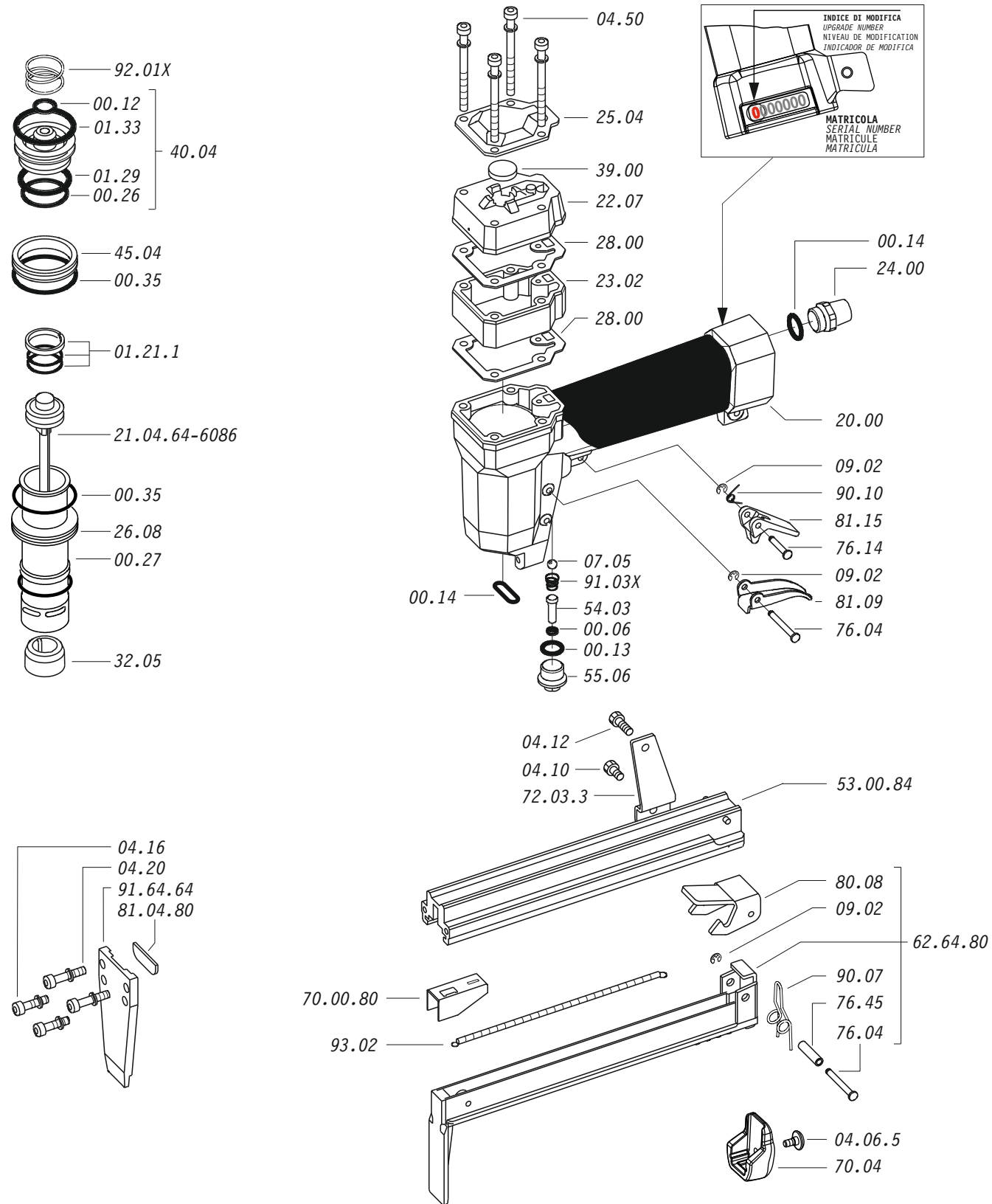

Dotazioni - Equipment - Ausstattung - Outillage - Dotaciones - Εξοπλισμός  
Dotações - Uitrusting - Donanımlar - Utrustning

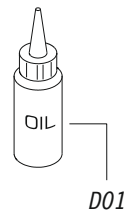

**64.16 SLNF**

cod. 1145440NF

Cod.	Descrizione	Description
00.04	O-Ring	O-Ring
00.06	O-Ring	O-Ring
00,12	O-Ring	O-Ring
00,13	O-Ring	O-Ring
00,14	O-Ring	O-Ring
00.26	O-Ring	O-Ring
00.27	O-Ring	O-Ring
00.35	O-Ring	O-Ring
01.21.1	Guarnizione	Gasket
01.29	O-Ring	O-Ring
01.33	O-Ring	O-Ring
04.06.5	Vite	Screw
04.10	Vite	Screw
04,12	Vite	Screw
04.16	Vite	Screw
04.20	Vite	Screw
04.50	Vite	Screw
07.05	Sfera	Ball
07.30	Chiave esagonale	Hex. bar wrench
09.02	Anello elastico	Elastic ring
20.00	Corpo	Body
22.07	Testa	Head
23.02	Prolunga	Extension
24.00	Silenziatore	Silencer
25.04	Deflettore	Exhaust deflector
26.08	Cilindro	Cylinder
28.00	Guarnizione	Gasket
32.05	Ammortizzatore	Bumper
39.00	Guarnizione scarico	Exhaust gasket
40.04	Valvola completa	Valve ass'y
45.04	Anello valvola	Ring
54.03	Pulsante	Trigger valve
55.06	Raccordo	Bush
70.04	Protezione	Guard
72.03.3	Reggicaricatore	Support
76.04	Perno	Pin
76.14	Perno	Pin
76.45	Perno molla	Pin
80.08	Grilletto chiusura	Trigger
81.09	Grilletto comando	Trigger
81.15	Controgrilletto	Safety
90.07	Molla	Spring
90.10	Molla	Spring
91.03X	Molla	Spring
92.01X	Molla	Spring
93.02	Molla	Spring
21.04.64-6086	Battente	Driver
53.00.84	Caricatore	Magazine
62.64.80	Carrello	Slider
70.00.80	Spingipunto	Pusher
81.04.80	Controtestina	Nose
91.64.64	Testina	Nose plate
D01	Bocchetta olio	Oiler

Guarnizioni - O-Rings - Dichtungen - Joints toriques - Juntas - Δακτύλιος στεγανοποίησης - Vedantes - O-ringen - Contalar - O-ringar

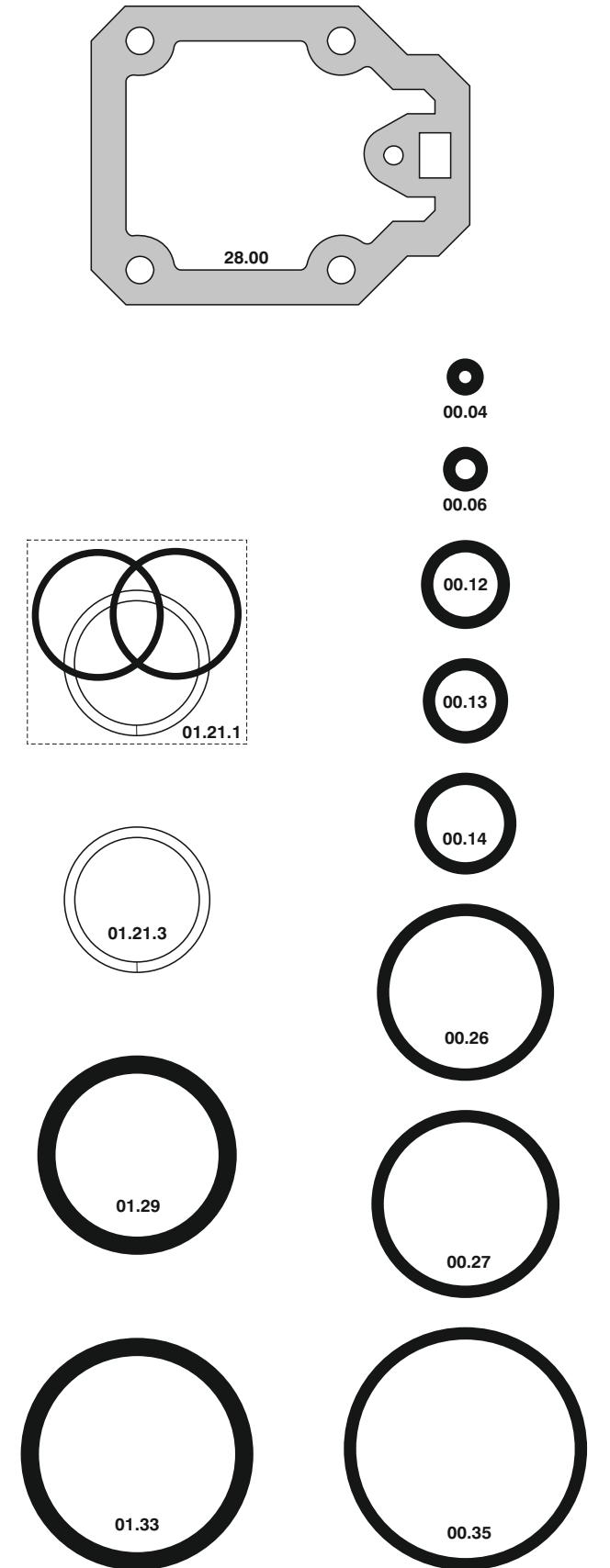

00.70.5

**64.16 SLNF**

cod. 1145440NF

Indice di modifica  
Upgrade number

4