

Azionamento a contatto
 Contact actuation

Oppure - Or

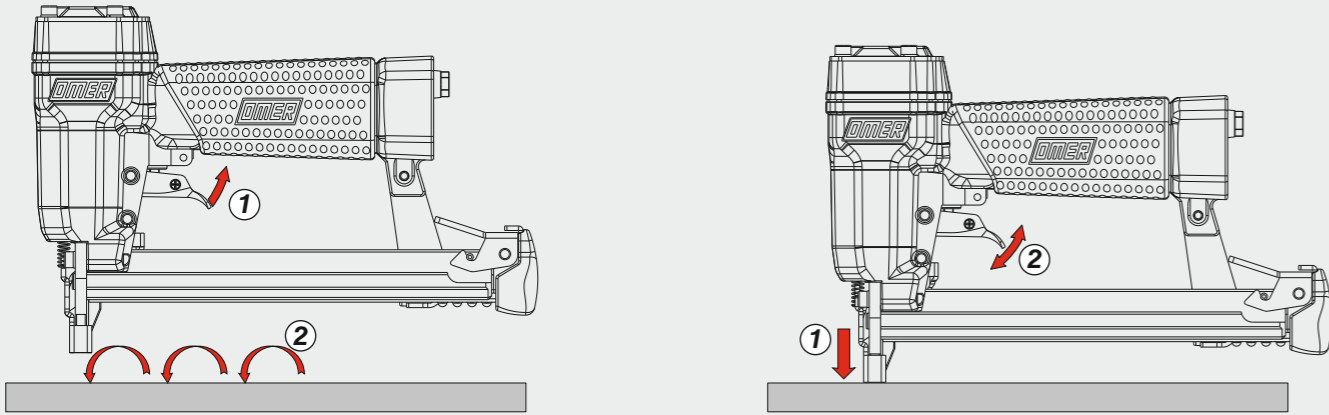

Caricamento - Loading - Laden - Chargement - Carga - Γέμισμα - Carregamento - Laden - Yükleme - Laddning - Plnění - Plnenie

Caricamento da sotto
 Bottom load magazine

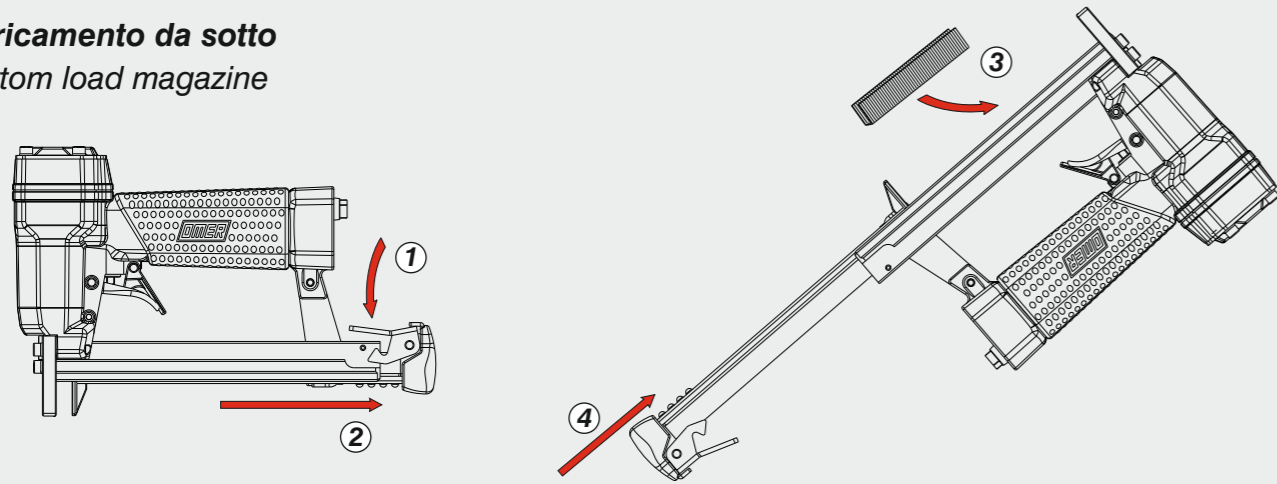

Disinceppamento - Jam clearing - Staubeseitigung - Décoincement - Desatascamiento - Απεμπλοκή
 Desencravamento - Deblokkering bij vastlopen - Sıkışma giderme - Rensning av igensättningar - Uvolnění - Uvoľnenie

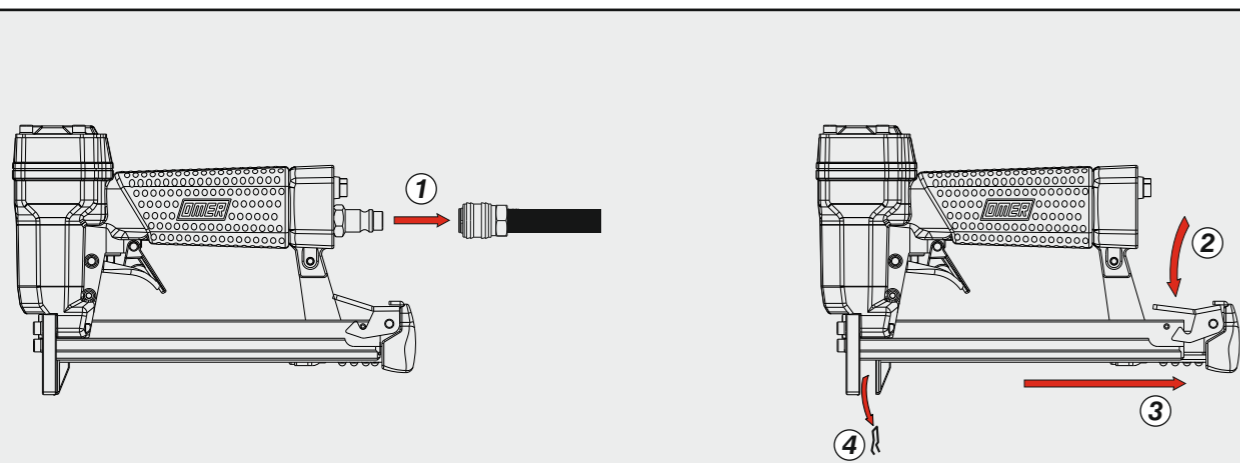

Manuale d'uso, manutenzione e parti di ricambio	Parte 2
Manual for use, maintenance and spare parts	Part 2
Bedienungs- und Wartungshandbuch sowie Ersatzteilliste	Teil 2
Mode d'emploi, de maintenance et pièces de rechange	Partie 2
Manual de uso, mantenimiento y recambios	Part 2
Εγχειρίδιο χρήσης, συντήρησης και ανταλλακτικών	Μέρος 2
Manual de uso, manutenção e peças sobresselentes	Parte 2
Handleiding voor gebruik, onderhoud en wisselstukken	Deel 2
Kullanım, bakım ve yedek parça kılavuzu	Kısım 2
Användar-, underhålls- och reservdelshandbok	Del 2
Návod k používání a údržbě a náhradní díly	Část 2
Návod na obsluhu, údržbu a náhradné diely	Časť 2



81P S

cod. 11561190



Warning: Please read the instructions and warnings for this tool carefully before use. Failure to do so could lead to serious injury.

Dati tecnici Technical data Technische Daten Tekniska data	Caractéristiques techniques Datos técnicos Τεχνικά χαρακτηριστικά Technické údaje	Dados técnicos Technische gegevens Teknik veriler Technické údaje		
Misure impiegabili Lengths Verwendbare Nagellänge Dimensioner som kan användas	Dimensions utiles Medidas de longitud Μήκος Αναλωσίμου Příпустné rozměry	Medidas utilizáveis Toepasbare afmetingen Boy Použitelné rozmery	mm inch	6 - 16 1/4" - 5/8"
Capacità caricatore n° punti Magazine capacity Magazinkapazität Nägel Magasinkapacitet Antal punkter	Capacité chargeur n° de points Capacidad cargador n° puntos Δυνατότητα γεμιστρα Kapacita zásobníku p. sponek	Capacidade carregador n° pontos Capaciteit magazijn in aantal spijkers Dergi kapasitesi Kapacita zásobníka p. spôn		90
Pressione d'esercizio Operating pressure Betriebsdruck Drifttryck	Pression d'exercice Presión de servicio Πίεση λειτουργίας Pracovní tlak	Pressão de serviço Werkdruk Çalışma basıncı Prevádzkový tlak	bar psi	4 - 6 60 - 90
Consumo aria Air consumption Luftverbrauch Luftförbrukning	Consommation d'air Consumo aire Κατανάλωση αέρα Spotřeba vzduchu	Consumo ar Luchtverbruik Hava tüketimi Spotřeba vzduchu	lt/colpo ft ³ /cycle	0,13 0,00459
Peso Weight Gewicht Vikt	Poids Peso Βάρος Hmotnost	Peso Gewicht Ağırlık Hmotnost	kg lbs	0,90 1,98
Dimensioni Dimensions Abmessungen Dimensioner (AxBxH)	Dimensions Dimensiones Διαστάσεις Rozměry	Dimensões Afmetingen Boyutlar Rozmery	mm inch	223x43x153 8-3/4"x1-11/16"x6-1/16" (LxWxH)
EN 12549 :2009 EN ISO 4871 :2009 Pressione sonora in pos. operatore Sound pressure in operator's position Schalldruck am Arbeitsplatz Ljudtryck på operatörsplatsen	Pression sonore poste Opérateur Presión sonora en la pos. del operador Ηχητική πίεση στη θέση του χειριστή Akustický tlak v místě obsluhy	Pressão sonora na posição Operador Geluidsdruk op de werkplaats Οπερατόρ ποζιςιοννδα ses basıncı Akustický tlak v mieste obsluhy	dB(A)	81 (K = 4 dB)
EN 12549 :2009 EN ISO 3746 :2011 EN ISO 4871 :2009 Potenza sonora emessa Sound power emitted Emitierte Schalleistung Avgiven ljudeffekt	Puissance sonore émise Potencia sonora emitida Εκπεμπόμενη ηχητική ισχύς Emitovaný akustický tlak	Potência sonora emitida Geëmitteerd geluidsvermogen Çıkan ses gücü (ses desibel) Výstupný akustický výkon	dB(A)	88 (K = 4 dB)
CEN ISO/TS 8662-11 :2006 EN ISO 5349-2 :2004 EN 12096 :1999 Emissione vibratoria sull'impugnatura Vibratory emissions on handle Vibrationsemission am Griff Vibrationsemission på handtaget	Émission vibratoire sur la prise en main Emisión de vibraciones en la empuñadura Εκπεμπόμενες δονήσεις στη λαβή Emise vibrací na rukojet	Emissão vibratória na empunhadura Trillingsemissie op de handgreep Tutamak üzerinde vibrasyon emisyonları Emisie vibrácií na rukováti	m/s ²	<2,5 (K = 2 m/s ²)

Tipo di punto
Type of fastener
Befestigungsmittel
Type de rivet
Tipo de punto
Τύπος αναλωσίμου
Tipo de agrafo
Type nietjes
Zimba ve çivi tipleri
Typ av stygn
Typ sponky
Typ spony

81P

1,10x1,25

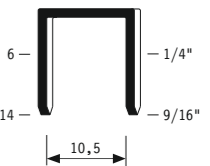

Crown: .500" (1/2")
 Gauge: 19

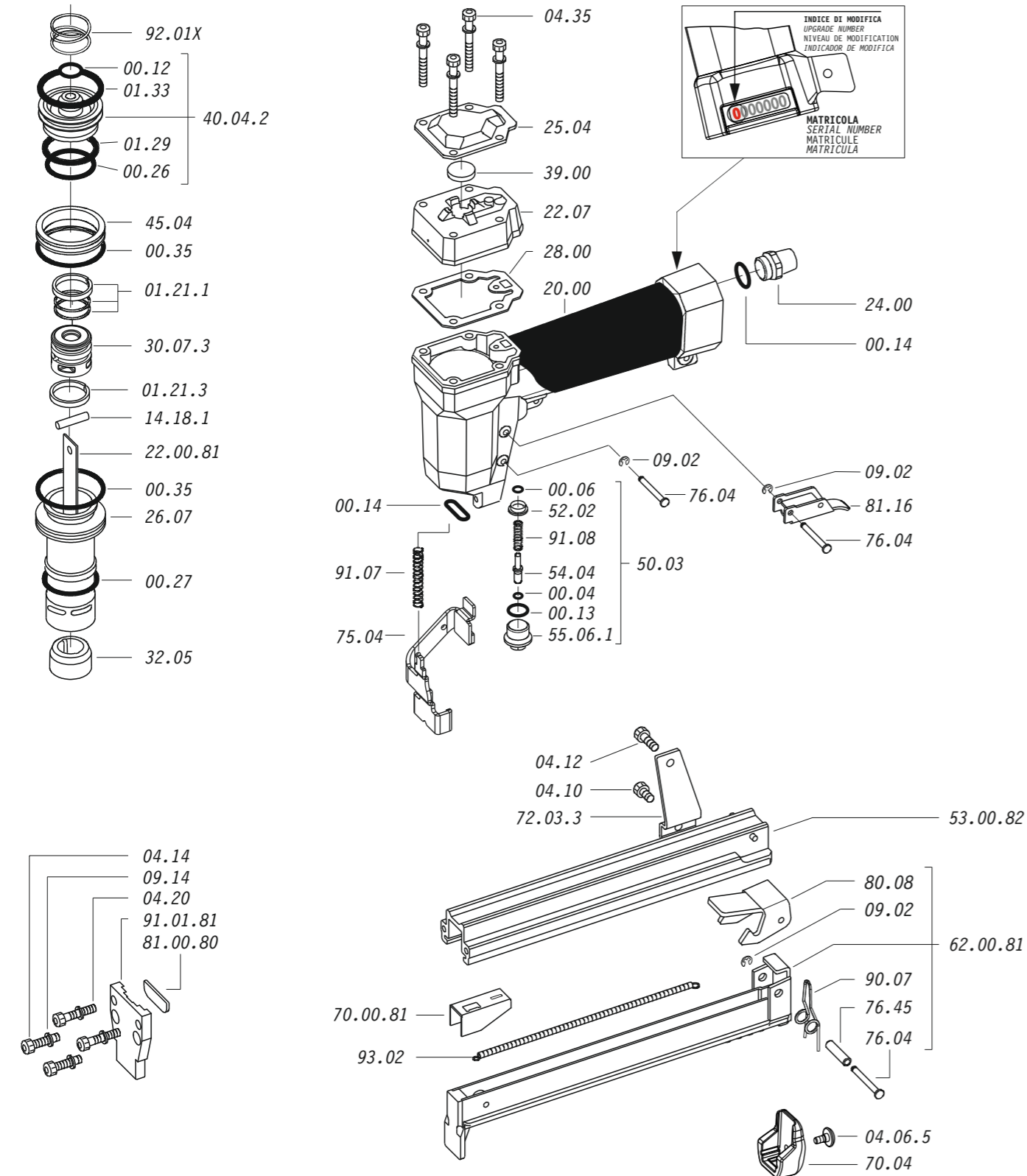

Dotazioni - Equipment - Ausstattung - Outillage - Dotaciones - Εξοπλισμός
Dotações - Uitrusting - Donanımlar - Utrustning - Vybavení - Vybava

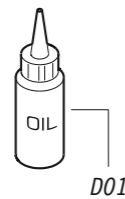

81P S

cod. 11561190

Cod.	Descrizione	Description
00.04	O-Ring	O-Ring
00.06	O-Ring	O-Ring
00.12	O-Ring	O-Ring
00.13	O-Ring	O-Ring
00.14	O-Ring	O-Ring
00.26	O-Ring	O-Ring
00.27	O-Ring	O-Ring
00.35	O-Ring	O-Ring
01.21.1	Guarnizione	Gasket
01.21.3	Guarnizione	Gasket
01.29	O-Ring	O-Ring
01.33	O-Ring	O-Ring
04.06.5	Vite	Screw
04.10	Vite	Screw
04.12	Vite	Screw
04.14	Vite	Screw
04.20	Vite	Screw
04.35	Vite	Screw
07.30	Chiave esagonale	Hex. bar wrench
09.02	Anello elastico	Elastic ring
09.14	Rondella	Washer
14.18.1	Spina	Pin
20.00	Corpo	Body
22.07	Testa	Head
24.00	Silenziatore	Silencer
25.04	Deflettore	Exhaust deflector
26.07	Cilindro	Cylinder
28.00	Guarnizione	Gasket
30.07.3	Pistone	Piston
32.05	Ammortizzatore	Bumper
39.00	Guarnizione scarico	Exhaust gasket
40.04.2	Valvola completa	Valve ass'y
45.04	Anello valvola	Ring
50.03	Pulsante completo	Trigger valve ass'y
52.02	Boccola	Bush
54.04	Pulsante	Trigger valve
55.06.1	Raccordo	Bush
70.04	Protezione	Guard
72.03.3	Reggicaricatore	Support
75.04	Sicura	Safety
76.04	Perno	Pin
76.45	Perno molla	Pin
80.08	Grilletto chiusura	Trigger
81.16	Grilletto comando	Trigger
90.07	Molla	Spring
91.07	Molla	Spring
91.08	Molla	Spring
92.01X	Molla	Spring
93.02	Molla	Spring
22.00.81	Battente	Driver
53.00.82	Caricatore	Magazine
62.00.81	Carrello	Slider
70.00.81	Spingipunto	Pusher
81.00.80	Controtestina	Nose
91.01.81	Testina	Nose plate
D01	Bocchetta olio	Oiler

Guarnizioni - O-Rings - Dichtungen - Joints toriques - Junta - Δακτύλιος στεγανοποίησης
Vedantes - O-ringen - Contalar - O-ringar - Těsnění - Tesnenia

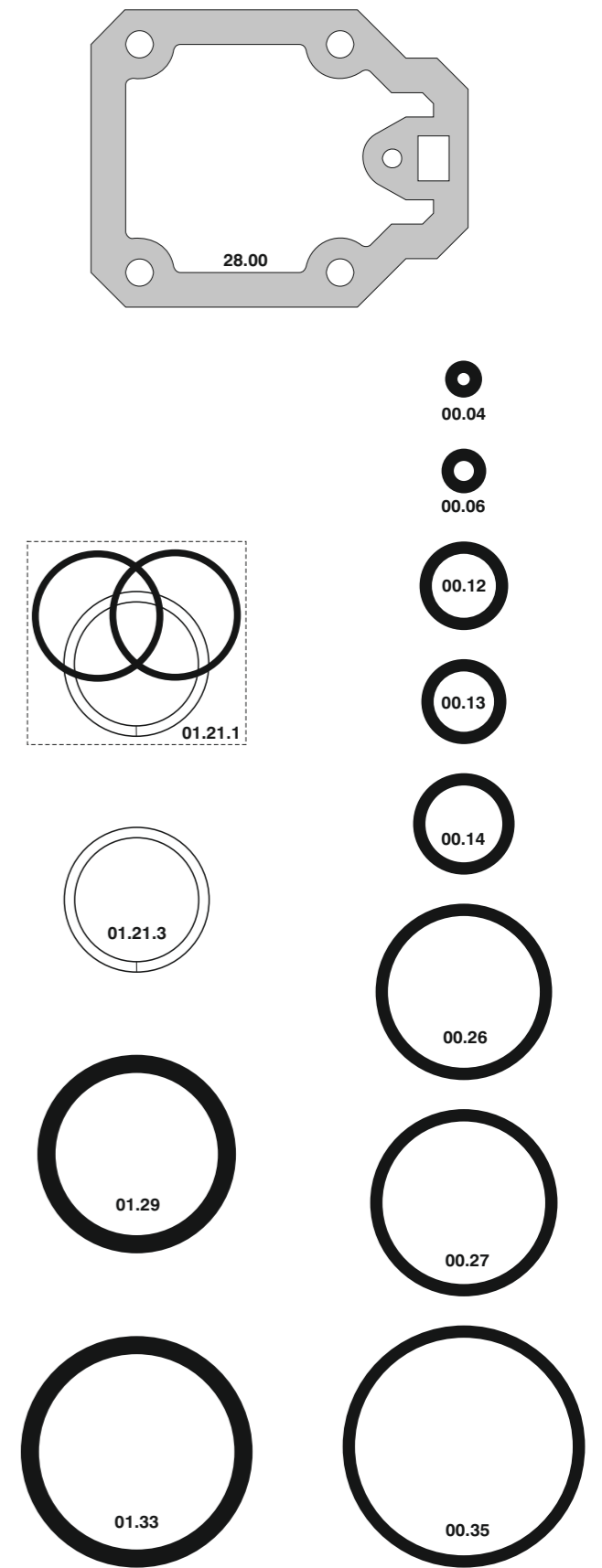

81P S

cod. 11561190

Indice di modifica
Upgrade number

5