

**Caricamento da sotto**  
Bottom load magazine

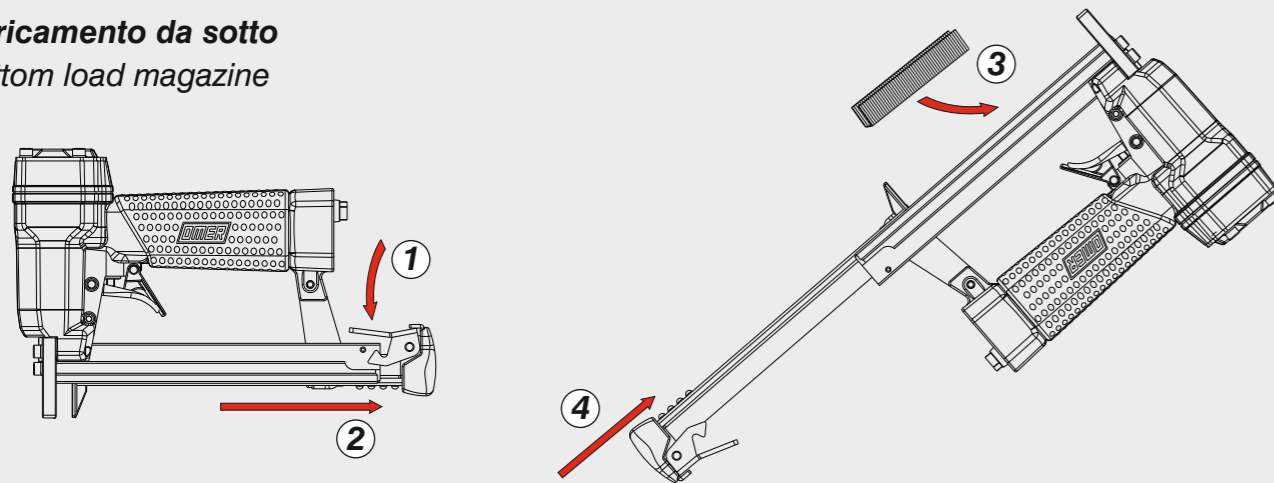

**Caricamento dischi - Disk loading**

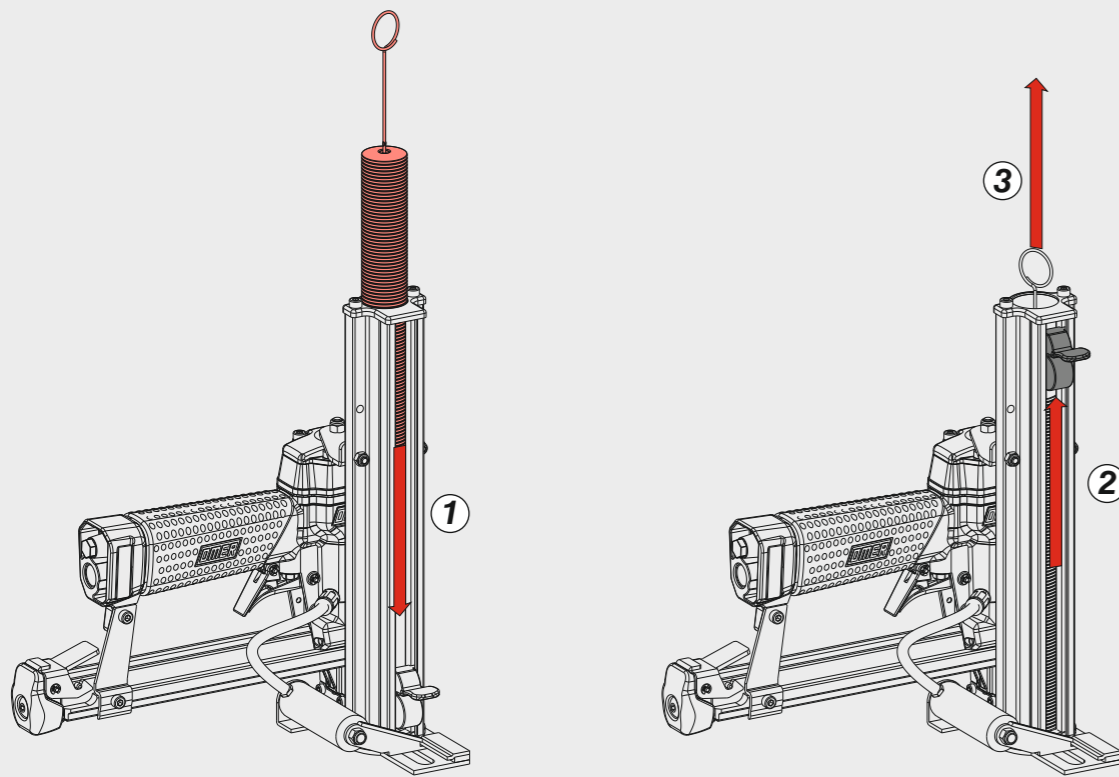

**Disinceppamento - Jam clearing - Staubeseitigung - Décoincement - Desatascamiento - Απεμπλοκή**  
Desencravamento - Deblokkering bij vastlopen - Sıkışma giderme - Rensning av igensättningar - Uvolnění - Uvol'nenie

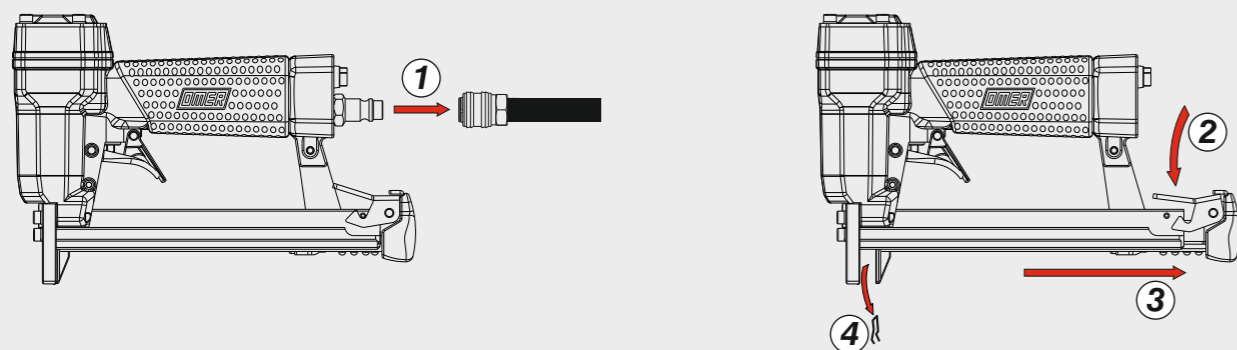

<b>Manuale d'uso, manutenzione e parti di ricambio</b>	<b>Parte 2</b>
<b>Manual for use, maintenance and spare parts</b>	<b>Part 2</b>
<b>Bedienungs- und Wartungshandbuch sowie Ersatzteilliste</b>	<b>Teil 2</b>
<b>Mode d'emploi, de maintenance et pièces de rechange</b>	<b>Partie 2</b>
<b>Manual de uso, mantenimiento y recambios</b>	<b>Part 2</b>
<b>Εγχειρίδιο χρήσης, συντήρησης και ανταλλακτικών</b>	<b>Μέρος 2</b>
<b>Manual de uso, manutenção e peças sobresselentes</b>	<b>Parte 2</b>
<b>Handleiding voor gebruik, onderhoud en wisselstukken</b>	<b>Deel 2</b>
<b>Kullanım, bakım ve yedek parça kılavuzu</b>	<b>Kisim 2</b>
<b>Användar-, underhålls- och reservdelshandbok</b>	<b>Del 2</b>
<b>Návod k používání a údržbě a náhradní díly</b>	<b>Část 2</b>
<b>Návod na obsluhu, údržbu a náhradné diely</b>	<b>Časť 2</b>



**83P DK**

cod. 1156390DK



<b>Dati tecnici</b> Technical data Technische Daten Tekniska data	<b>Caractéristiques techniques</b> Datos técnicos Τεχνικά χαρακτηριστικά Technické údaje	<b>Dados técnicos</b> Technische gegevens Teknik veriler Technické údaje		
<b>Misure impiegabili</b> Lengths Verwendbare Nagellänge Dimensioner som kan användas	<b>Dimensions utiles</b> Medidas de longitud Μήκος Αναλωσίμου Příпустné rozměry	<b>Medidas utilizáveis</b> Toepasbare afmetingen Boy Použitelné rozmery	<b>mm</b>	<b>10 ÷ 16</b> <b>3/8" ÷ 5/8"</b>
<b>Capacità caricatore n° punti</b> Magazine capacity Magazinkapazität Nägel Magasinkapacitet Antal punkter	<b>Capacité chargeur n° de points</b> Capacidad cargador n° puntos Δυνατότητα γεμιστερα Kapacita zásobníku p. sponek	<b>Capacidade carregador n° pontos</b> Capaciteit magazijn in aantal spijkers Dergi kapasitesi Kapacita zásobníka p. spôn		<b>80</b> <b>&amp;</b> <b>(100 disk)</b>
<b>Pressione d'esercizio</b> Operating pressure Betriebsdruck Driftryck	<b>Pression d'exercice</b> Presión de servicio Πίεση λειτουργίας Pracovní tlak	<b>Pressão de serviço</b> Werkdruk Çalışma basıncı Prevádzkový tlak	<b>bar</b> <b>psi</b>	<b>5 ÷ 6,5</b> <b>70 ÷ 95</b>
<b>Consumo aria</b> Air consumption Luftverbrauch Luftförbrukning	<b>Consommation d'air</b> Consumo aire Κατανάλωση αέρα Spotřeba vzduchu	<b>Consumo ar</b> Luchtverbruik Hava tüketimi Spotřeba vzduchu	<b>lt/colpo</b> <b>ft³/cycle</b>	<b>0,18</b> <b>0,0632</b>
<b>Peso</b> Weight Gewicht Vikt	<b>Poids</b> Peso Βάρος Hmotnost	<b>Peso</b> Gewicht Ağırlık Hmotnost	<b>kg</b> <b>lbs</b>	<b>1,60</b> <b>3,53</b>
<b>Dimensioni</b> Dimensions Abmessungen Dimensioner (AxBxH)	<b>Dimensions</b> Dimensiones Διαστάσεις Rozměry	<b>Dimensões</b> Afmetingen Boyutlar Rozmery	<b>mm</b> <b>inch</b>	<b>223x128x265</b> <b>8-25/32"x5-1/32"x10-7/16"</b> <b>(LxWxH)</b>
<b>EN 12549 :2009 EN ISO 4871 :2009</b>	<b>Pressione sonora in pos. operatore</b> Sound pressure in operator's position Schalldruck am Arbeitsplatz Ljudtryck på operatörsplatsen	<b>Pressão sonora na posição Operador</b> Geluidsdruk op de werkplaats Οπερατόρ ποζιسیونδα ses basıncı Akustický tlak v místě obsluhy	<b>dB(A)</b>	<b>81</b> <b>(K= 4 dB)</b>
<b>EN 12549 :2009 EN ISO 3746 :2011 EN ISO 4871 :2009</b>	<b>Potenza sonora emessa</b> Sound power emitted Emittierte Schalleistung Avgiven ljudeffekt	<b>Potência sonora emitida</b> Geëmitteerd geluidsvermogen Çıkan ses gücü (ses desibeli) Výstupný akustický výkon	<b>dB(A)</b>	<b>88</b> <b>(K= 4 dB)</b>
<b>CEN ISO/TS 8662-11 :2006 EN ISO 5349-2 :2004 EN 12096 :1999</b>	<b>Emissione vibratoria sull'impugnatura</b> Vibratory emissions on handle Vibrationsemission am Griff Vibrationsemission på handtaget	<b>Emissão vibratória na empunhadura</b> Trillingsemissie op de handgreep Tutamak üzerinde vibrasyon emisyonları Emisie vibrácií na rukováti	<b>m/s²</b>	<b>&lt;2,5</b> <b>(K= 2 m/s²)</b>



**Tipo di punto**  
Type of fastener  
Befestigungsmittel  
Type de rivet  
Tipo de punto  
Τύπος αναλωσίμου  
Tipo de agrafó  
Type nietjes  
Zimba ve çivi tipleri  
Typ av stygn  
Typ sponky  
Typ spony

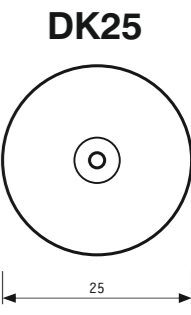
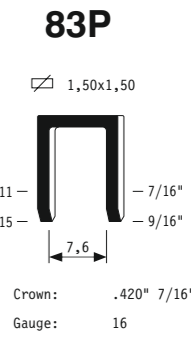

1156390DK\_83PDK\_5\_rev22\_27/09/2024\_DV

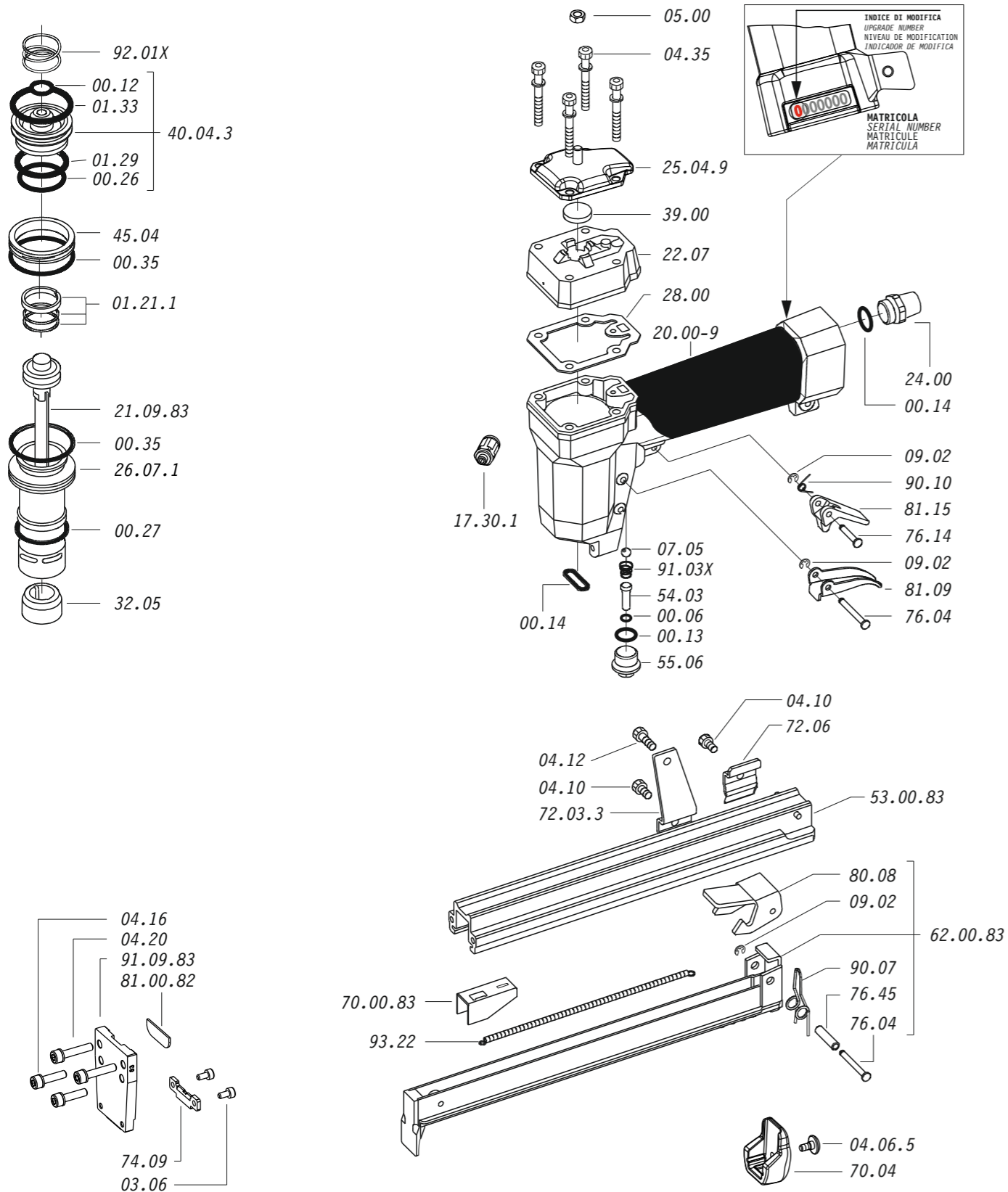

Dotazioni - Equipment - Ausstattung - Outillage - Dotaciones - Εξοπλισμός  
Dotações - Uitrusting - Donanımlar - Utrustning - Vybavení - Vybava

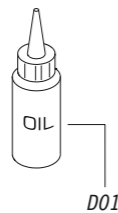
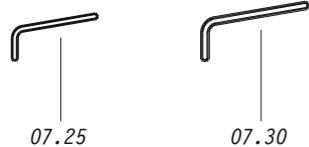

**83P DK**

cod. 1156390DK

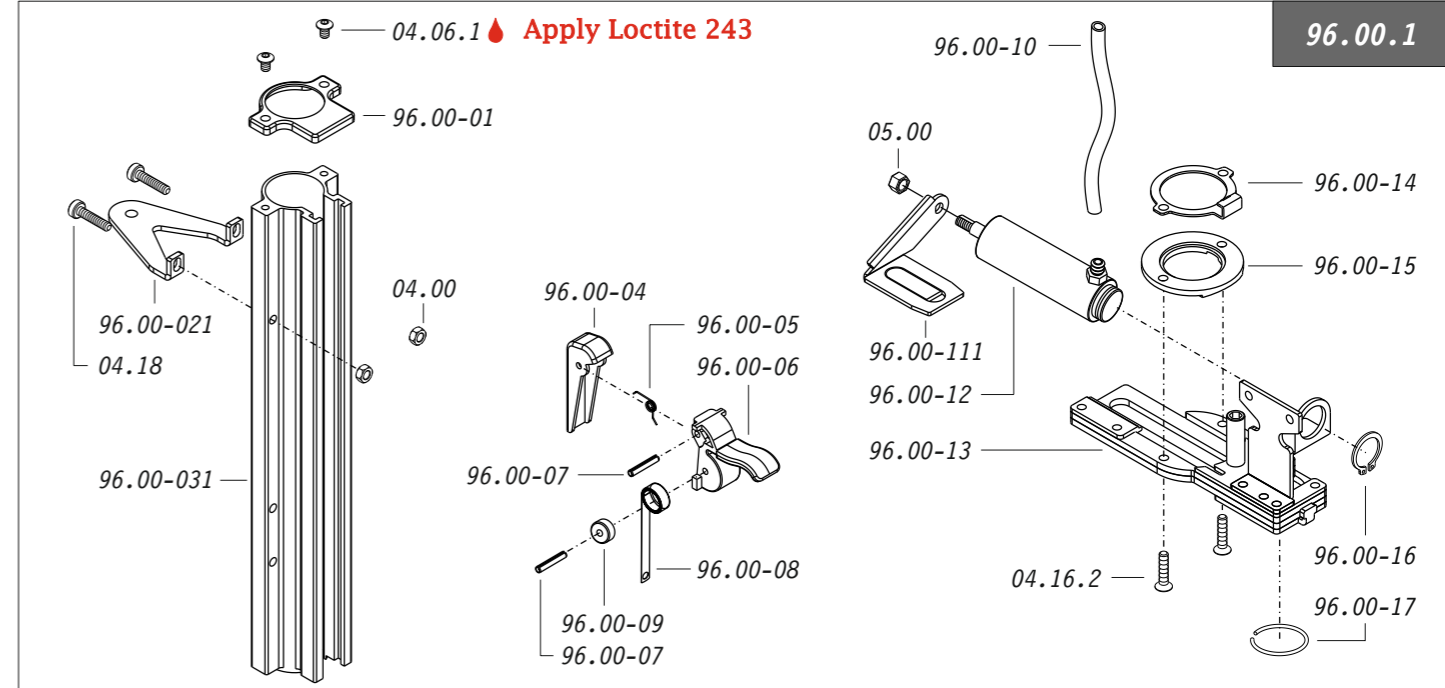

Cod.	Descrizione	Description
00.06	O-Ring	O-Ring
00.12	O-Ring	O-Ring
00.13	O-Ring	O-Ring
00.14	O-Ring	O-Ring
00.26	O-Ring	O-Ring
00.27	O-Ring	O-Ring
00.35	O-Ring	O-Ring
01.21.1	Guarnizione	Gasket
01.29	O-Ring	O-Ring
01.33	O-Ring	O-Ring
03.06	Vite	Screw
04.00	Dado	Nut
04.06.1	Vite	Screw
04.06.5	Vite	Screw
04.10	Vite	Screw
04.12	Vite	Screw
04.16	Vite	Screw
04.16.2	Vite	Screw
04.18	Vite	Screw
04.20	Vite	Screw
04.35	Vite	Screw
05.00	Dado	Nut
07.05	Sfera	Ball
07.25	Chiave esagonale	Hex. bar wrench
07.30	Chiave esagonale	Hex. bar wrench
09.02	Anello elastico	Elastic ring
17.30.1	Attacco	Connection

Cod.	Descrizione	Description
20.00-9	Corpo	Body
22.07	Testa	Head
24.00	Silenziatore	Silencer
25.04.9	Deflettore	Exhaust deflector
26.07.1	Cilindro	Cylinder
28.00	Guarnizione	Gasket
32.05	Ammortizzatore	Bumper
39.00	Guarnizione scarico	Exhaust gasket
40.04.3	Valvola completa	Valve ass'y
45.04	Anello valvola	Ring
54.03	Pulsante	Trigger valve
55.06	Raccordo	Bush
70.02.9K	Supporto bilanciante	Tool hangers
70.04	Protezione	Guard
72.03.3	Reggicaricatore	Support
72.06	Fermo carrello	Slider stop
74.09	Piastrina	Plate
76.04	Perno	Pin
76.14	Perno	Pin
76.45	Perno molla	Pin
80.08	Grilletto chiusura	Trigger
81.09	Grilletto comando	Trigger
81.15	Controgrilletto	Safety
90.07	Molla	Spring
90.10	Molla	Spring
91.03X	Molla	Spring
92.01X	Molla	Spring

Cod.	Descrizione	Description
93.22	Molla	Spring
96.00.1	Kit caricatore disc.	Magazine disk Kit
96.00-01	Tappo	Cap
96.00-021	Supporto	Support
96.00-031	Caricatore dischi	Disk magazine
96.00-04	Spingidisco	Pusher
96.00-05	Molla	Spring
96.00-06	Leva	Latch
96.00-07	Perno	Pin
96.00-08	Molla	Spring
96.00-09	Rullo molla	Roller
96.00-10	Tubo	Tube
96.00-111	Alimentatore dischi	Disk feeder
96.00-12	Pistone	Piston
96.00-13	Piastra	Plate
96.00-14	Anello	Ring
96.00-15	Anello	Ring
96.00-16	Anello elastico	Elastic ring
96.00-17	Anello	Ring
21.09.83	Battente	Driver
53.00.83	Caricatore	Magazine
62.00.83	Carrello	Slider
70.00.83	Spingipunto	Pusher
81.00.82	Controtestina	Nose
91.09.83	Testina	Nose plate
D01	Bocchetta olio	Oiler

Guarnizioni - O-Rings - Dichtungen - Joints toriques - Juntas - Δακτύλιος στεγανοποίησης  
Vedantes - O-ringen - Contalar - O-ringar - Těsnění - Tesnenia

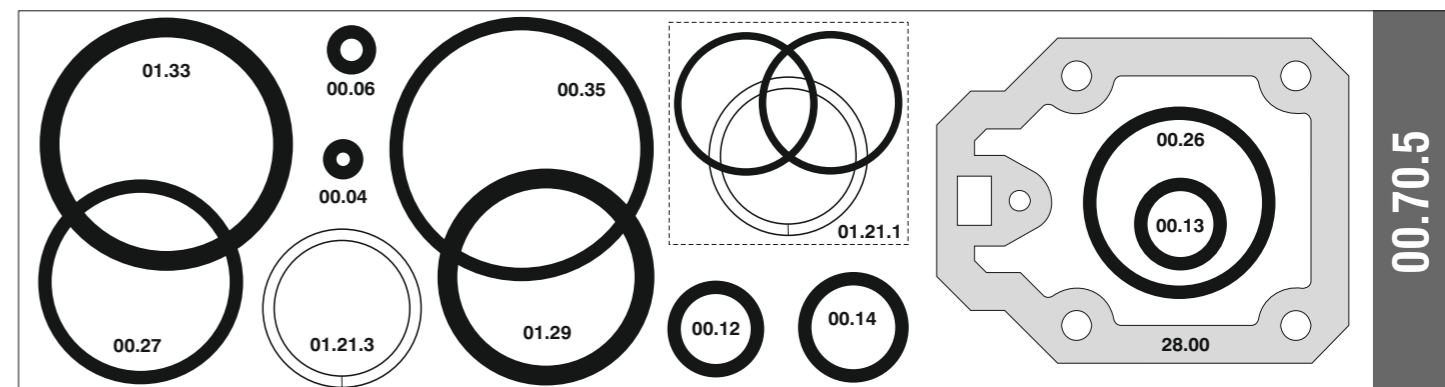

**83P DK**

cod. 1156390DK

Indice di modifica  
Upgrade number

**5**

### Azionamento singolo con doppia attivazione

Single actuation with dual activation

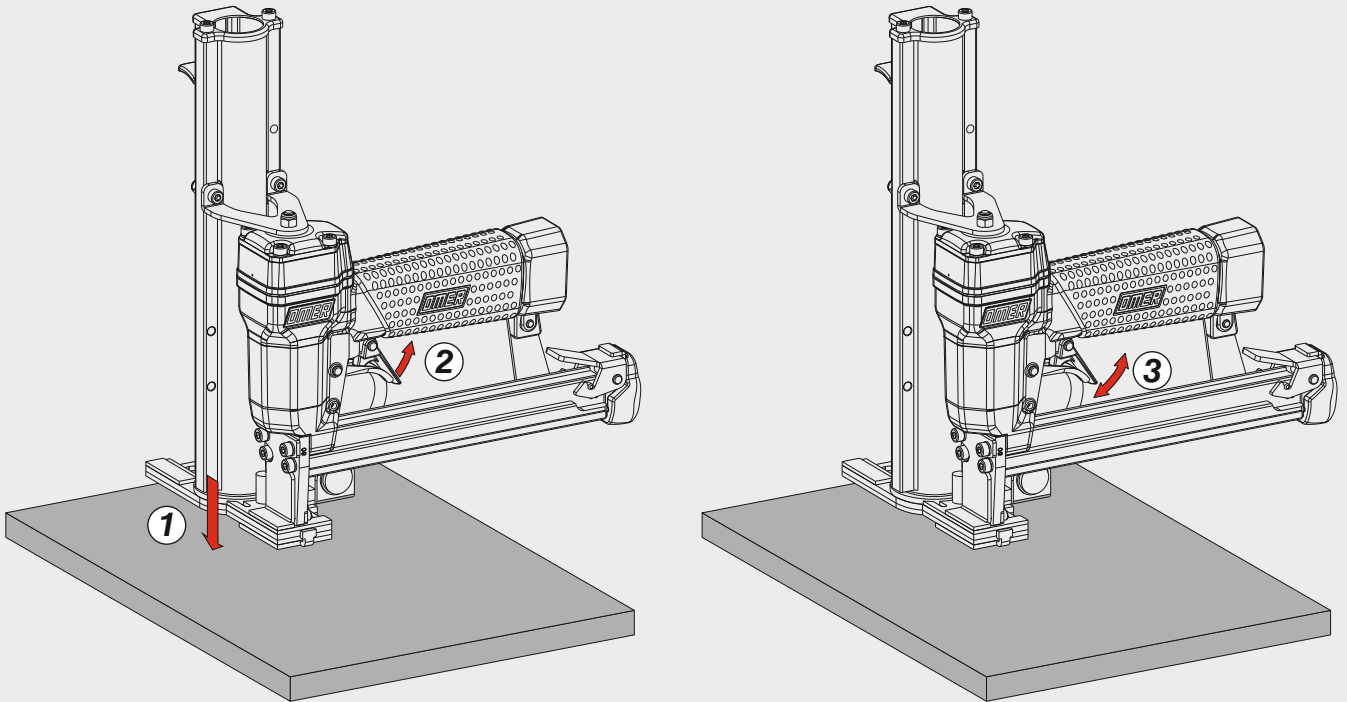

### Supporto bilanciante - Tool hangers

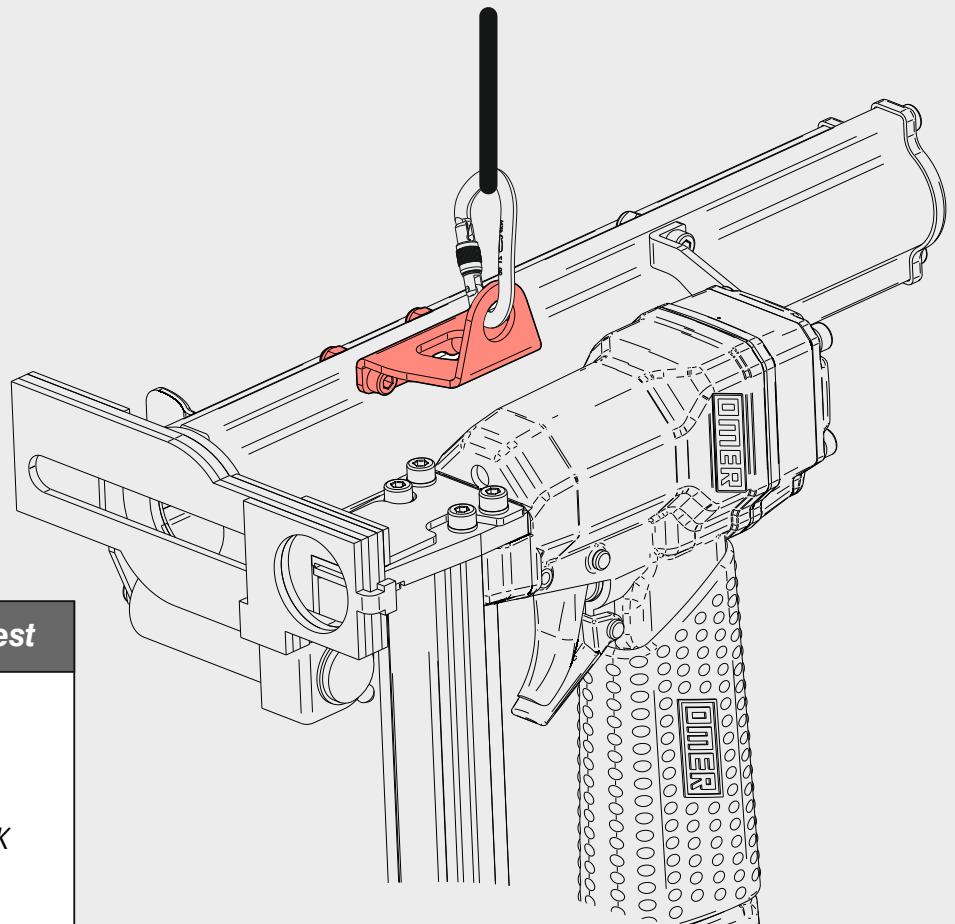

A richiesta - On request

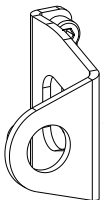

70.02.9K