

**Azionamento singolo con doppia attivazione**  
 Single actuation with dual activation

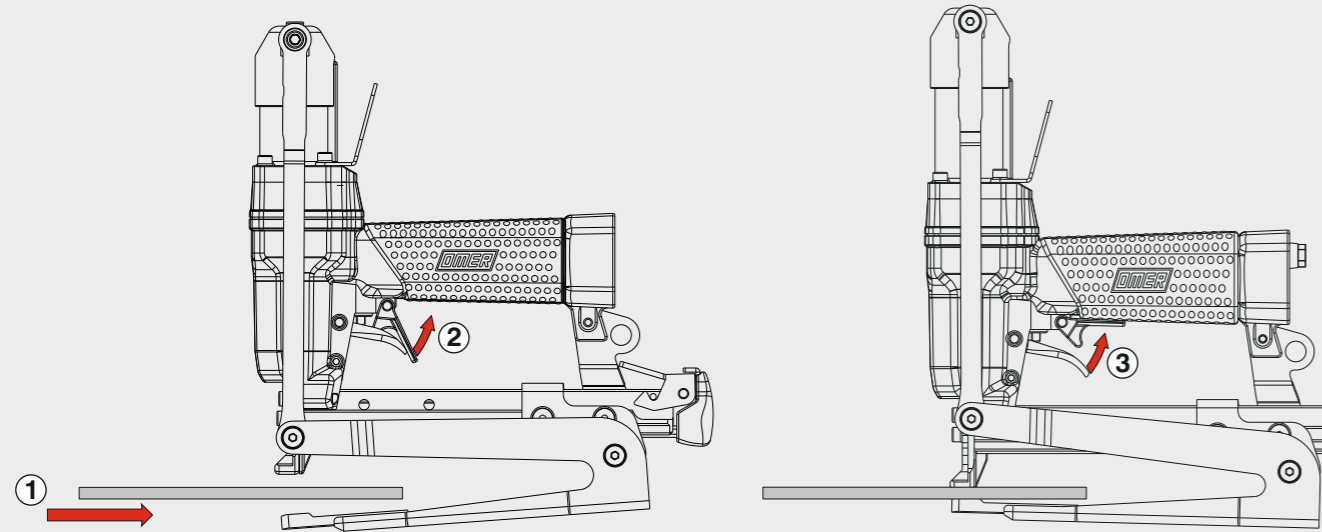

**Caricamento - Loading - Laden - Chargement - Carga - Γέμισμα - Carregamento - Laden - Yükleme - Laddning - Plnění - Plnenie**

**Caricamento da sotto**  
 Bottom load magazine

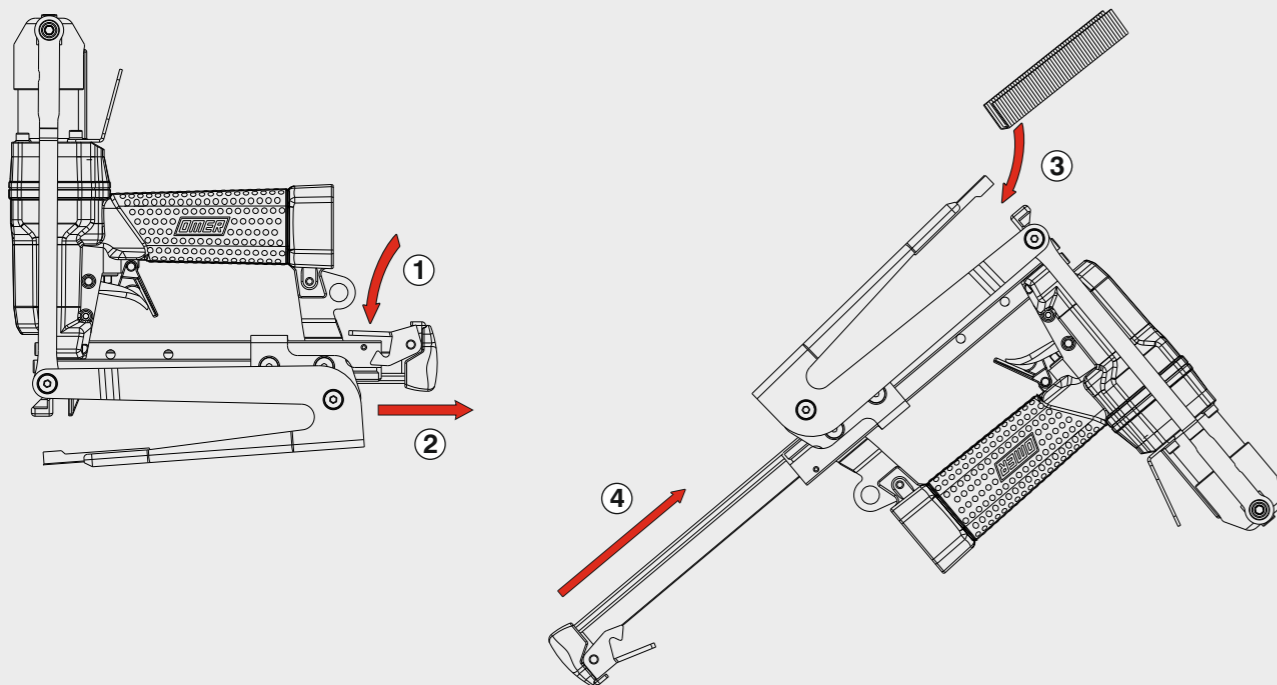

<b>Manuale d'uso, manutenzione e parti di ricambio</b>	<b>Parte 2</b>
<b>Manual for use, maintenance and spare parts</b>	<b>Part 2</b>
<b>Bedienungs- und Wartungshandbuch sowie Ersatzteilliste</b>	<b>Teil 2</b>
<b>Mode d'emploi, de maintenance et pièces de rechange</b>	<b>Partie 2</b>
<b>Manual de uso, mantenimiento y recambios</b>	<b>Part 2</b>
<b>Εγχειρίδιο χρήσης, συντήρησης και ανταλλακτικών</b>	<b>Μέρος 2</b>
<b>Manual de uso, manutenção e peças sobresselentes</b>	<b>Parte 2</b>
<b>Handleiding voor gebruik, onderhoud en wisselstukken</b>	<b>Deel 2</b>
<b>Kullanım, bakım ve yedek parça kılavuzu</b>	<b>Kisim 2</b>
<b>Användar-, underhålls- och reservdelshandbok</b>	<b>Del 2</b>
<b>Návod k používání a údržbě a náhradní díly</b>	<b>Část 2</b>
<b>Návod na obsluhu, údržbu a náhradné diely</b>	<b>Časť 2</b>



**PL50.16 LJC-03**

cod. 11567530C-03



<b>Dati tecnici</b> Technical data Technische Daten Tehniska data	<b>Caractéristiques techniques</b> Datos técnicos Τεχνικά χαρακτηριστικά Technické údaje	<b>Dados técnicos</b> Technische gegevens Teknik veriler Technické údaje		
<b>Misure impiegabili</b> Lengths Verwendbare Nagellänge Dimensioner som kan användas	Dimensions utiles Medidas de longitud Μήκος Αναλωσίμου Příпустné rozměry	Medidas utilizáveis Toepasbare afmetingen Boy Použitelné rozmery	<b>mm</b> <b>inch</b>	<b>10÷16</b> <b>3/8"÷5/8"</b>
<b>Capacità caricatore n° punti</b> Magazine capacity Magazinkapazität: Nägel Μαγασινάκι: Αριθμός βελών Magasínkapacitét: Antal punkter	Capacité chargeur n° de points Capacidad cargador n° puntos Δυνατότητα γεμιστέρας Kapacita zásobníku p. sponek	Capacidade carregador n° pontos Capaciteit magazijn in aantal spijkers Dergi kapasitesi Kapacita zásobníka p. spôn		<b>105</b>
<b>Pressione d'esercizio</b> Operating pressure Betriebsdruck Drifttryck	Pression d'exercice Presión de servicio Πίεση λειτουργίας Pracovní tlak	Pressão de serviço Werkdruk Çalışma basıncı Prevádzkový tlak	<b>bar</b> <b>psi</b>	<b>4,5÷6,5</b> <b>65÷95</b>
<b>Consumo aria</b> Air consumption Luftverbrauch Luftförbrukning	Consommation d'air Consumo aire Κατανάλωση αέρα Spotřeba vzduchu	Consumo ar Luchtverbruik Hava tüketimi Spotřeba vzduchu	<b>lt/colpo</b> <b>ft<sup>3</sup>/cycle</b>	<b>0,20</b> <b>0,01227</b>
<b>Peso</b> Weight Gewicht Vikt	Poids Peso Βάρος Hmotnost	Peso Gewicht Ağırlık Hmotnost	<b>kg</b> <b>lbs</b>	<b>1,70</b> <b>3,75</b>
<b>Dimensioni</b> Dimensions Abmessungen Dimensioner (AxBxH)	Dimensions Dimensiones Διαστάσεις Rozměry	Dimensões Afmetingen Boyutlar Rozmery	<b>mm</b> <b>inch</b>	<b>223x64x249</b> <b>8-25/32"x2-1/2"x9-13/16"</b> <b>(LxWxH)</b>
<b>EN 12549 :2009 EN ISO 4871 :2009</b> <b>Pressione sonora in pos. operatore</b> Sound pressure in operator's position Schalldruck am Arbeitsplatz Ljudtryck på operatörsplatsen	Pression sonore poste Opérateur Presión sonora en la pos. del operador Ηχητική πίεση στη θέση του χειριστή Akustický tlak v místě obsluhy	Pressão sonora na posição Operador Geluidsdruk op de werkplaats Operatör pozisyonunda ses basıncı Akustický tlak v mieste obsluhy	<b>dB(A)</b>	<b>88</b> <b>(K= 4 dB)</b>
<b>EN 12549 :2009 EN ISO 3746 :2011 EN ISO 4871 :2009</b> <b>Potenza sonora emessa</b> Sound power emitted Emitierte Schalleistung Avgiven ljudeffekt	Puissance sonore émise Potencia sonora emitida Εκπεμπόμενη ηχητική ισχύς Emitovaný akustický tlak	Potência sonora emitida Geëmitteerd geluidsvermogen Çıkan ses gücü (ses desibeli) Výstupný akustický výkon	<b>dB(A)</b>	<b>95</b> <b>(K= 4 dB)</b>
<b>CEN ISO/TS 8662-11 :2006 EN ISO 5349-2 :2004 EN 12096 :1999</b> <b>Emissione vibratoria sull'impugnatura</b> Vibratory emissions on handle Vibrationsemission am Griff Vibrationsemission på handtaget	Émission vibratoire sur la prise en main Emisión de vibraciones en la empuñadura Εκπεμπόμενες δονήσεις στη λαβή Emise vibrací na rukojet	Emissão vibratória na empunhadura Trillingsemissie op de handgreep Tutamak üzerindeki vibrasyon emisyonları Emisie vibrácií na rukoväti	<b>m/s<sup>2</sup></b>	<b>3,15</b> <b>(K= 2 m/s<sup>2</sup>)</b>

**Stapling results**



**Tipo di punto**  
Type of fastener  
Befestigungsmittel  
Type de rivet  
Tipo de punto  
Τύπος αναλωσίμου  
Tipo de agrafó  
Type nietjes  
Zimba ve çivi tipleri  
Typ av stygn  
Typ sponky  
Typ spony

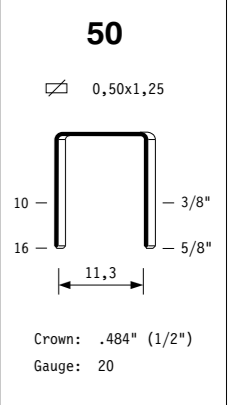

11567530C-03\_PL5016LJC-03\_5\_rev24\_16/10/2024\_DV

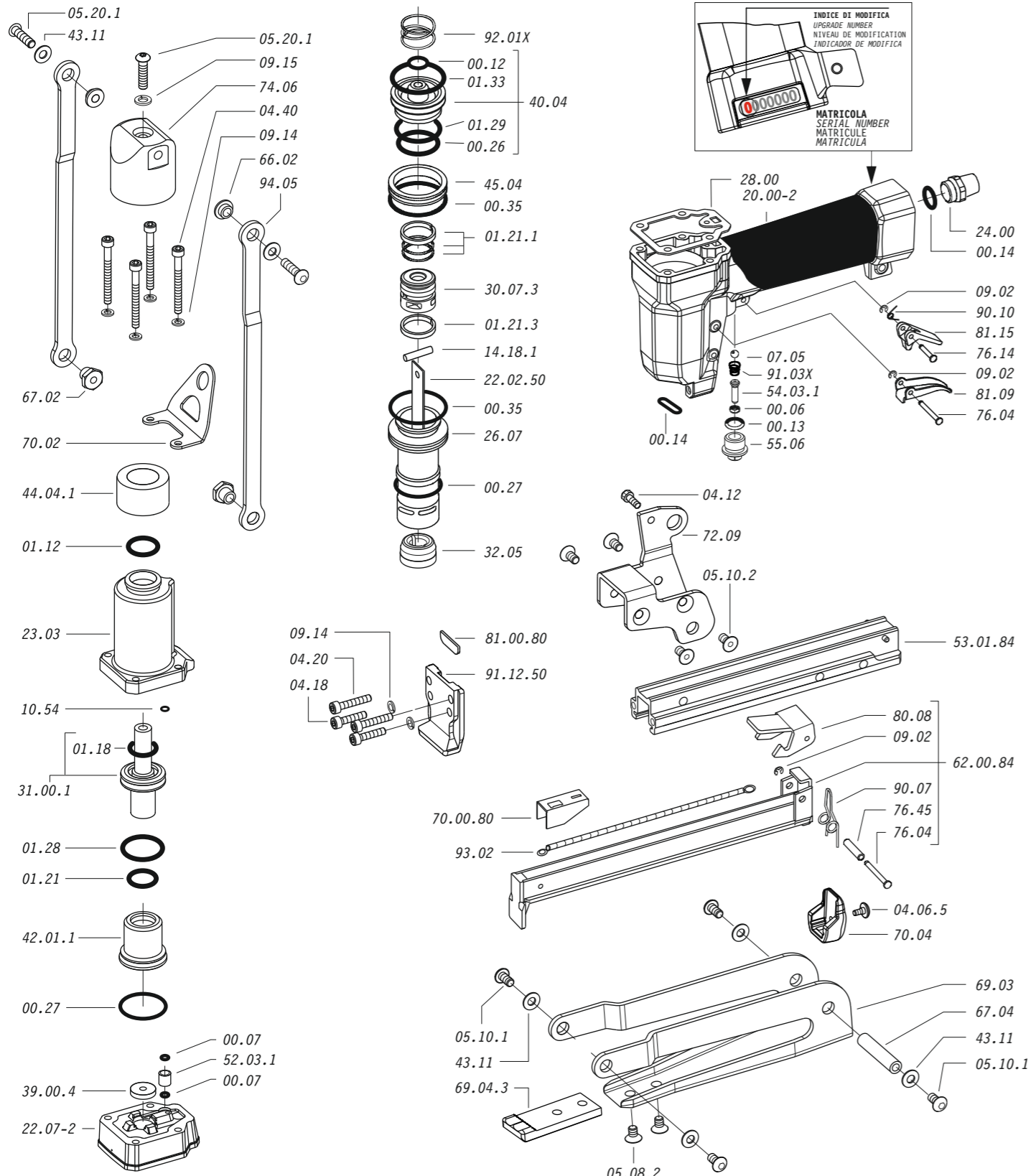

Dotazioni - Equipment - Ausstattung - Outillage - Dotaciones - Εξοπλισμός  
Dotações - Uitrusting - Donanımlar - Utrustning - Vybavení - Vybava



**PL50.16 LJC-03**

cod. 11567530C-03

Cod.	Descrizione	Description
00.06	O-Ring	O-Ring
00.07	O-Ring	O-Ring
00.12	O-Ring	O-Ring
00.13	O-Ring	O-Ring
00.14	O-Ring	O-Ring
00.26	O-Ring	O-Ring
00.27	O-Ring	O-Ring
00.35	O-Ring	O-Ring
01.12	O-Ring	O-Ring
01.18	O-Ring	O-Ring
01.21	O-Ring	O-Ring
01.21.1	Guarnizione	Gasket
01.21.3	Guarnizione	Gasket
01.28	O-Ring	O-Ring
01.29	O-Ring	O-Ring
01.33	O-Ring	O-Ring
04.06.5	Vite	Screw
04.12	Vite	Screw
04.18	Vite	Screw
04.20	Vite	Screw
04.40	Vite	Screw
05.08.2	Vite	Screw
05.10.1	Vite	Screw
05.10.2	Vite	Screw
05.20.1	Vite	Screw
07.05	Sfera	Ball
07.30	Chiave esagonale	Hex. bar wrench
09.02	Anello elastico	Elastic ring
09.14	Rondella	Washer
09.15	Rondella	Washer
10.54	O-Ring	O-Ring
14.18.1	Spina	Pin
20.00-2	Corpo	Body
22.07-2	Testa	Head
23.03	Testa superiore	Head
24.00	Silenziatore	Silencer
26.07	Cilindro	Cylinder
28.00	Guarnizione	Gasket
30.07.3	Pistone	Piston
31.00.1	Pistone ganascia	Jaws Piston
32.05	Ammortizzatore	Bumper
39.00.4	Guarnizione scarico	Exhaust gasket
40.04	Valvola completa	Valve ass'y
42.01.1	Anello superiore	Upper ring
43.11	Rondella	Washer
44.04.1	Ammortizzatore	Bumper
45.04	Anello valvola	Ring
52.03.1	Distanziale	Pacer
54.03.1	Pulsante	Trigger valve
55.06	Raccordo	Bush
66.02	Boccola	Bush
67.02	Boccola	Bush
67.04	Boccola	Bush
69.03	Ganascia	Jaws
69.04.3	Ribattitore	Riveter
70.02	Supporto	Support
70.04	Protezione	Guard
72.09	Reggicaricatore	Support
74.06	Staffa	Bracket
76.04	Perno	Pin
76.14	Perno	Pin
76.45	Perno molla	Pin
80.08	Grilletto chiusura	Trigger
81.09	Grilletto comando	Trigger
81.15	Controgrilletto	Safety
90.07	Molla	Spring
90.10	Molla	Spring
91.03X	Molla	Spring
92.01X	Molla	Spring
93.02	Molla	Spring
94.05	Tirante	Connecting rod
22.02.50	Battente	Driver
53.01.84	Caricatore	Magazine
62.00.84	Carrello	Slider
70.00.80	Spingipunto	Pusher
81.00.80	Controtestina	Nose
91.12.50	Testina	Nose plate
D01	Bocchetta olio	Oiler

Guarnizioni - O-Rings - Dichtungen - Juntas - Δακτύλιος στεγανοποίησης  
Vedantes - O-ringen - Contalar - O-ringar - Tésnéni - Tesnenia

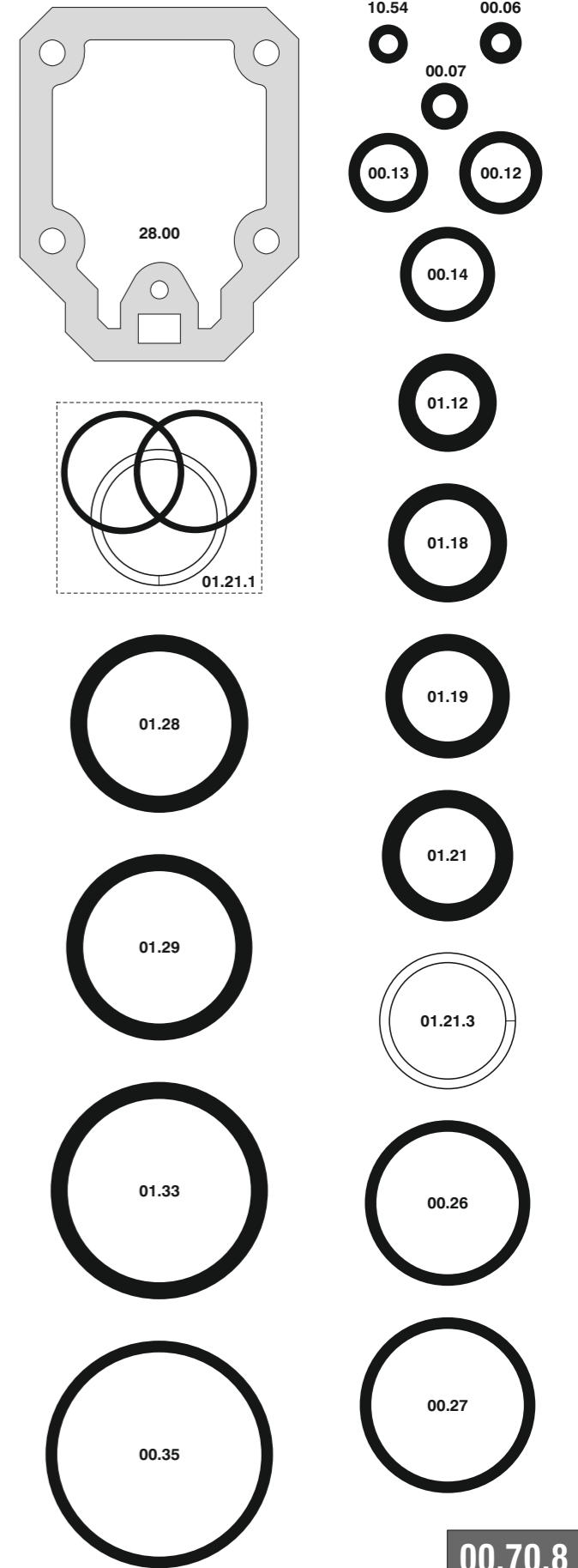

**PL50.16 LJC-03**

cod. 11567530C-03

Indice di modifica  
Upgrade number

**5**

Disinceppamento - Jam clearing - Staubeseitigung - Décoincement - Desatascamiento - Απεμπλοκή  
Desencravamento - Deblokkering bij vastlopen - Sıkışma giderme - Rensning av igensättningar - Uvolňení - Uvolňenie

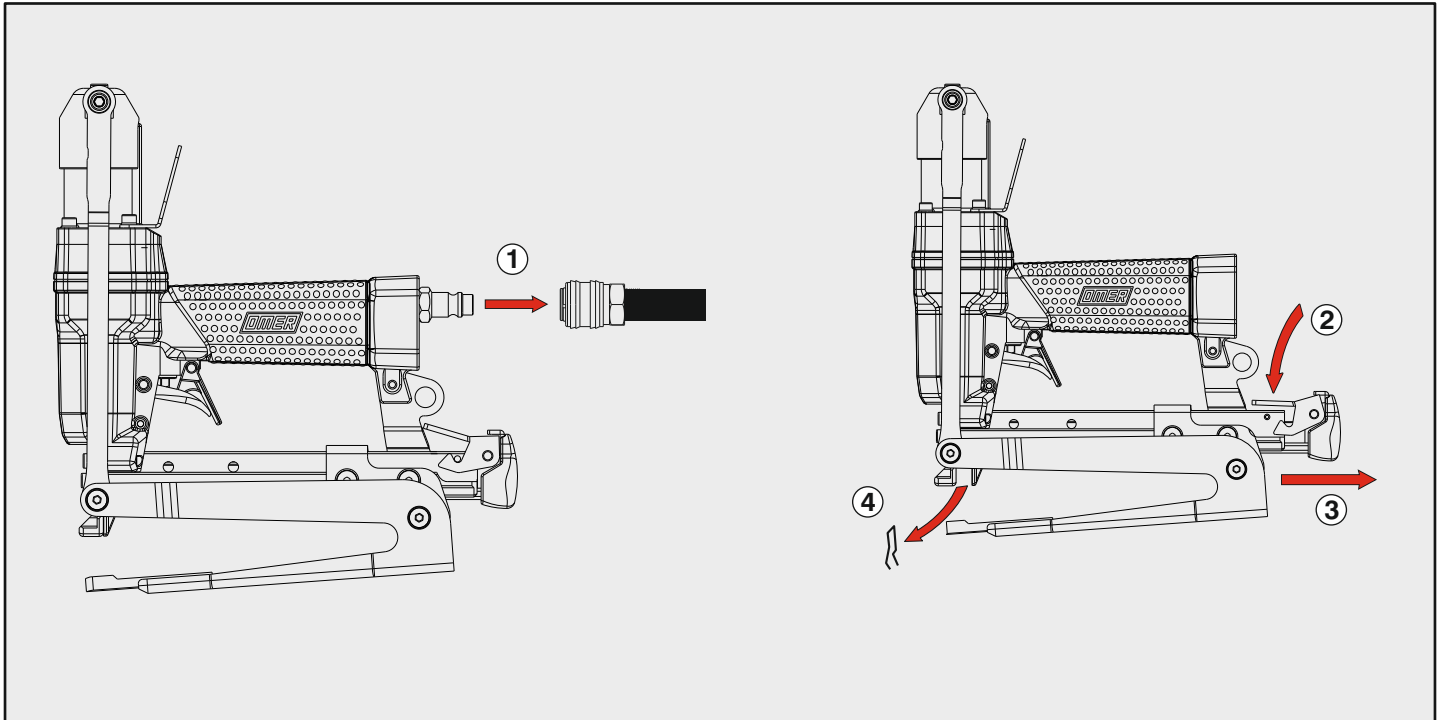

Caratteristiche - Features - Merkmale - Caractéristiques - Características  
Χαρακτηριστικά - Características - Kenmerken - Özellikler - Funktionen - Vlastnosti - Vlastnosti

**Spessore**  
Thickness

