

Schema di collegamento - Connecting diagram

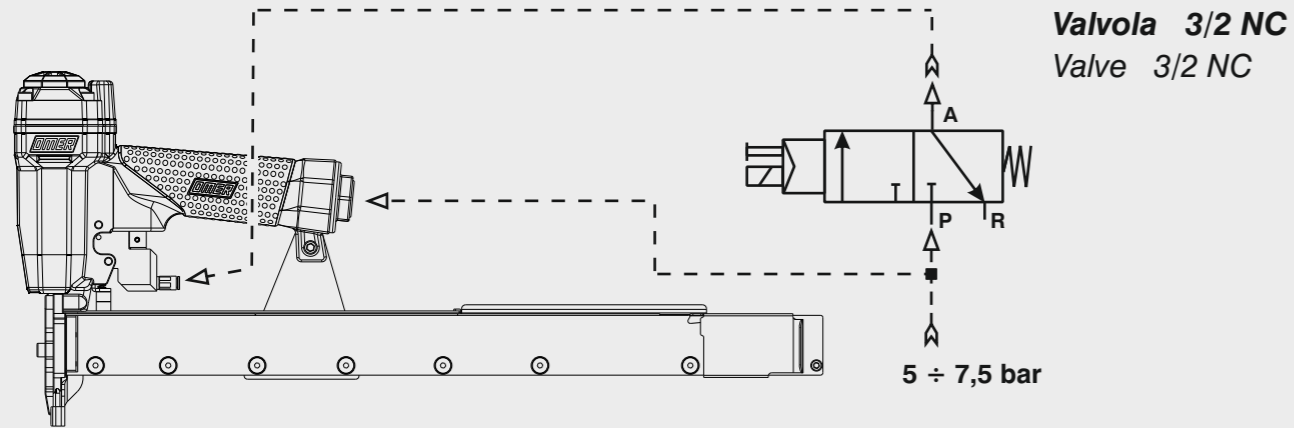

Caricamento - Loading - Laden - Chargement - Carga - Γέμισμα - Carregamento - Laden - Yükleme - Laddning - Plnění - Plnenie

Caricamento da sopra Top load magazine

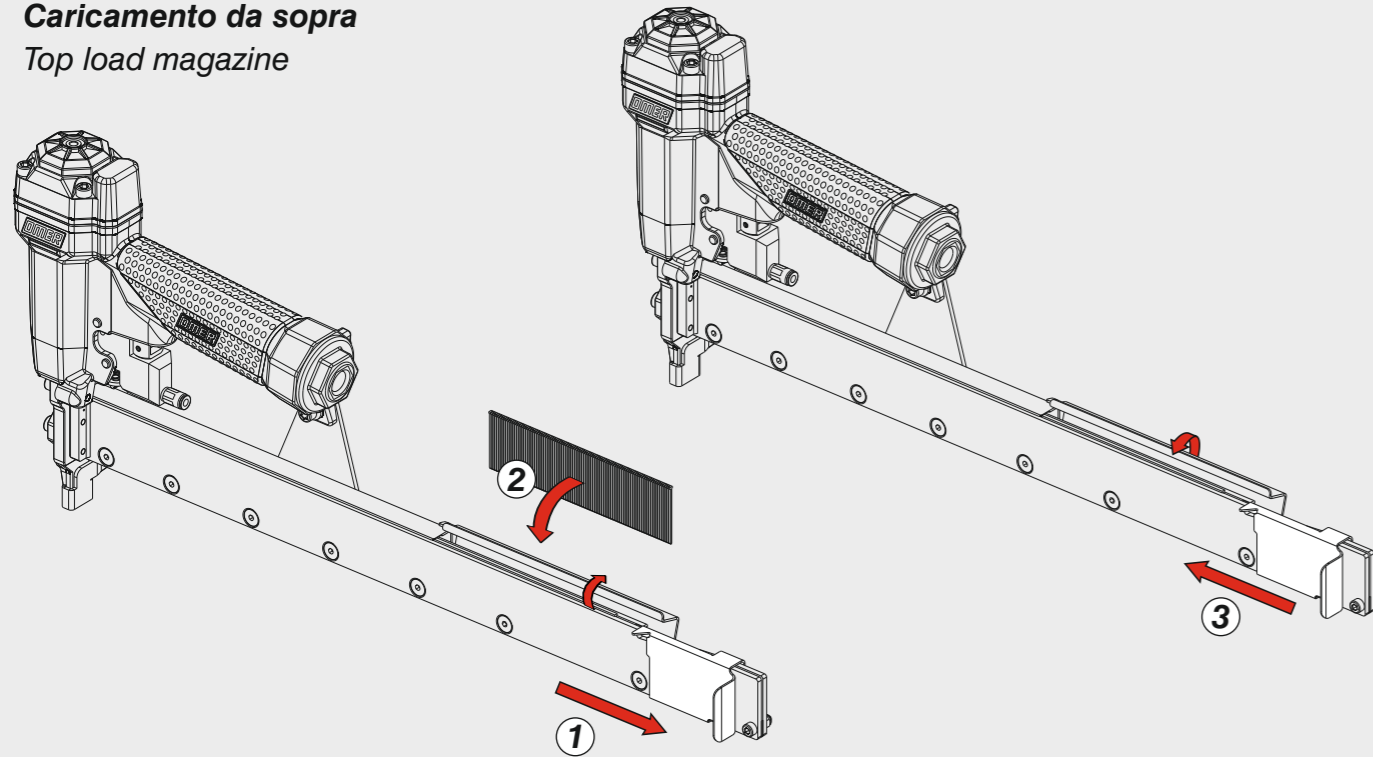

Disincerramento - Jam clearing - Staubeseitigung - Décoincement - Desatascamiento - Απεμπλοκή
Desencravamento - Deblokkering bij vastlopen - Sıkışma giderme - Rensning av igensättningar - Uvolnění - Uvol'nenie

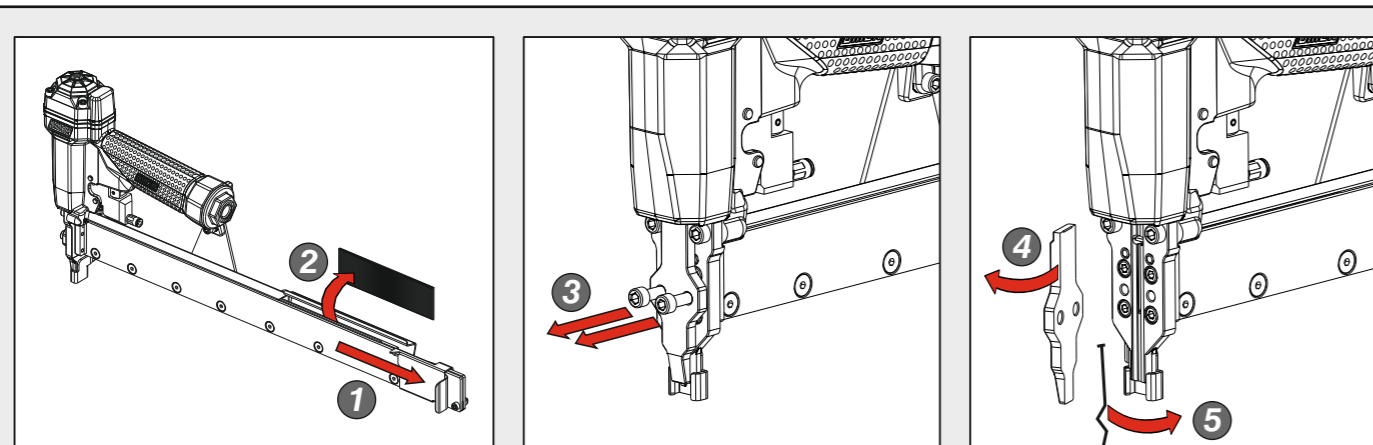

OMER

Manuale d'uso, manutenzione e parti di ricambio
Manual for use, maintenance and spare parts
Bedienungs- und Wartungshandbuch sowie Ersatzteilleiste
Mode d'emploi, de maintenance et pièces de rechange
Manual de uso, mantenimiento y recambios
Εγχειρίδιο χρήσης, συντήρησης και ανταλλακτικών
Manual de uso, manutenção e peças sobresselentes
Handleiding voor gebruik, onderhoud en wisselstukken
Kullanım, bakım ve yedek parça kılavuzu
Användar-, underhålls- och reservdelshandbok
Návod k používání a údržbě a náhradní díly
Návod na obsluhu, údržbu a náhradné diely

Parte 2
Part 2
Teil 2
Partie 2
Part 2
Μέρος 2
Parte 2
Deel 2
Kisim 2
Del 2
Část 2
Čast 2

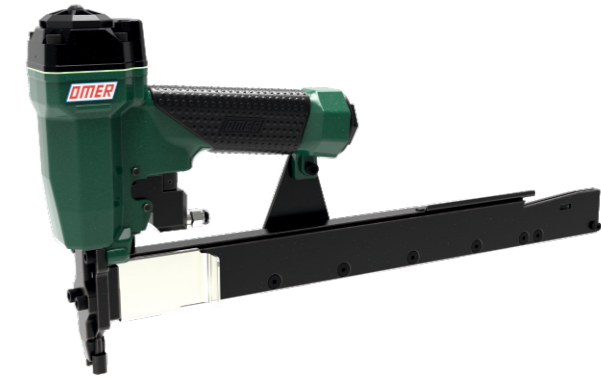

14.25 CLT4

cod. 12214540



Dati tecnici

Technical data
Technische Daten
Tehniska data

Caractéristiques techniques

Datos técnicos
Τεχνικά χαρακτηριστικά
Technické údaje

Dados técnicos

Technische gegevens
Teknik veriler
Technické údaje

Misure impiegabili

Lengths
Verwendbare Nagellänge
Dimensioner som kan användas

Dimensions utiles

Medidas de longitud
Μήκος Αναλωσίμου
Příпустné rozměry

Medidas utilizáveis

Toepasbare afmetingen
Boy
Použitelné rozmery

mm **13+25**

inch **1/2" + 1"**

Capacità caricatore n° punti

Magazine capacity
Magazinkapazität Nägel
Magasinkapacitet Antal punkter

Capacité chargeur n° de points

Capacidad cargador n° puntos
Δυνατότητα γεμιστερα
Kapacita zásobníku p. sponek

Capacidade carregador n° pontos

Capaciteit magazijn in aantal spijkers
Dergi kapasitesi
Kapacita zásobníka p. spôn

200

Pressione d'esercizio

Operating pressure
Betriebsdruck
Drifttryck

Pression d'exercice

Presión de servicio
Πίεση λειτουργίας
Pracovní tlak

Pressão de serviço

Werkdruk
Çalışma basıncı
Prevádzkový tlak

bar **5 ÷ 7,5**

psi **70 ÷ 105**

Consumo aria

Air consumption
Luftverbrauch
Luftförbrukning

Consommation d'air

Consumo aire
Κατανάλωση αέρα
Spotreba vzduchu

Consumo ar

Luchtverbruik
Hava tüketimi
Spotreba vzduchu

lt/colpo **0,34**

ft³/cycle **0,02087**

Peso

Weight
Gewicht
Vikt

Poids

Peso
Βάρος
Hmotnost

Peso

Gewicht
Ağırlık
Hmotnost

kg **2,14**

lbs **4,72**

Dimensioni

Dimensions
Abmessungen
Dimensioner (AxBxH)

Dimensions

Dimensiones
Διαστάσεις
Rozměry

Dimensões

Afmetingen
Boyutlar
Rozmery

mm **455x50x220**

inch **14-29/32"x2"x8-21/32"**

(LxWxH)

EN 12549 :2009 EN ISO 3746 :2011 EN ISO 4871 :2009

Potenza sonora emessa

Sound power emitted
Emitierte Schalleistung
Avgiven ljudeffekt

Puissance sonore émise

Potencia sonora emitida
Εκτεμπόμενη ηχητική ισχύς
Emitovaný akustický tlak

Potência sonora emitida

Geëmitteerd geluidsvermogen
Çıkan ses gücü (ses desibeli)
Výstupný akustický výkon

dB(A) **89**

(K = 4 dB)

12214540_1425CLT4_2_rev22_06/11/2024 MG

**DO NOT
HANDHELD
THIS TOOL**



Tipo di punto

Type of fastener
Befestigungsmittel
Type de rivet
Tipo de punto
Τύπος αναλωσίμου
Tipo de agrafo
Type nietjes
Zimba ve çivi tipleri
Typ av stygn
Typ sponky
Typ spony

Brads 14

1,40x1,60

2,7

13 - 1/2"

25 - 1"

Head width: .108"

Gauge: 16

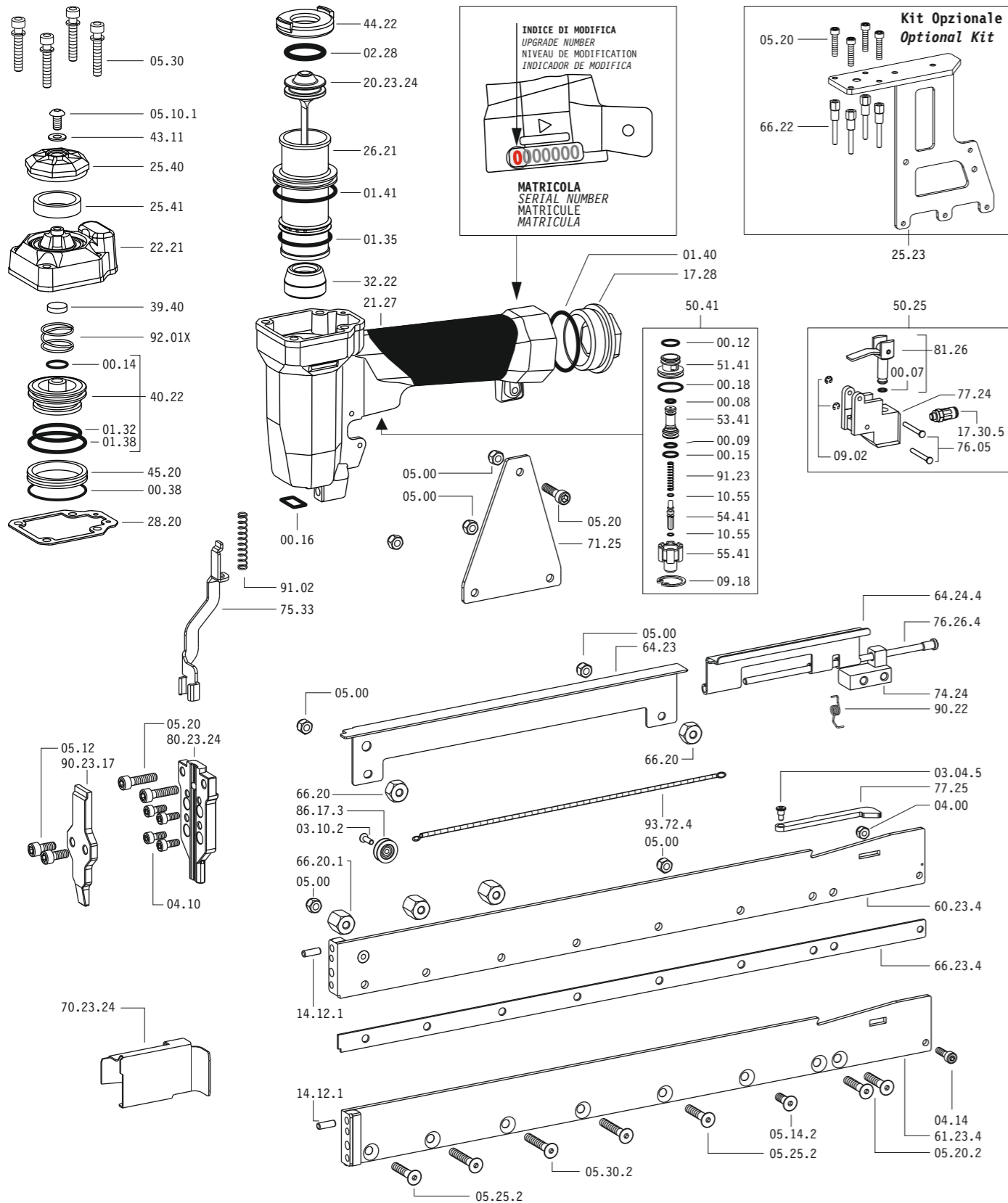

Dotazioni - Equipment - Ausstattung - Outillage - Dotaciones - Εξοπλισμός
Dotações - Uitrusting - Donanımlar - Utrustning - Vybavení - Vybava

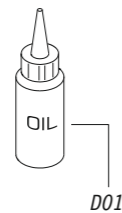

14.25 CLT4

cod. 12214540

Cod.	Descrizione	Description
00.07	O-Ring	O-Ring
00.08	O-Ring	O-Ring
00.09	O-Ring	O-Ring
00.12	O-Ring	O-Ring
00.14	O-Ring	O-Ring
00.15	O-Ring	O-Ring
00.16	O-Ring	O-Ring
00.18	O-Ring	O-Ring
00.38	O-Ring	O-Ring
01.32	O-Ring	O-Ring
01.35	O-Ring	O-Ring
01.38	O-Ring	O-Ring
01.40	O-Ring	O-Ring
01.41	O-Ring	O-Ring
02.28	O-Ring	O-Ring
03.04.5	Vite	Screw
03.10.2	Vite	Screw
04.00	Dado	Nut
04.10	Vite	Screw
04.14	Vite	Screw
05.00	Dado	Nut
05.10.1	Vite	Screw
05.12	Vite	Screw
05.14.2	Vite	Screw
05.20	Vite	Screw
05.20.2	Vite	Screw
05.25	Vite	Screw
05.25.2	Vite	Screw
05.30	Vite	Screw
05.30.2	Vite	Screw
07.30	Chiave esagonale	Hex. bar wrench
07.40	Chiave esagonale	Hex. bar wrench
09.02	Anello elastico	Elastic ring
09.18	Anello elastico	Elastic ring
10.55	O-Ring	O-Ring
14.12.1	Spina	Pin
17.28	Tappo	Inlet cap
17.30.5	Attacco	Connection
21.27	Corpo	Body
22.21	Testa	Head
25.23	Supporto	Support
25.40	Deflettore	Exhaust deflector
25.41	Silenziatore	Silencer
26.21	Cilindro	Cylinder
28.20	Guarnizione testa	Head gasket
32.22	Ammortizzatore	Bumper
39.40	Guarnizione scarico	Exhaust seal
40.22	Valvola completa	Valve ass'y
43.11	Rondella	Washer
44.22	Guarnizione	Gasket
45.20	Anello valvola	Ring
50.25	Comando a distanza	Remote control
50.41	Pulsante completo	Trigger valve ass'y
51.41	Boccola pulsante	Trigger valve housing
53.41	Pistone servovalvola	Valve piston
54.41	Pulsante	Trigger valve
55.41	Raccordo pulsante	Bush
60.23.4	Guida Sx	Left guide
61.23.4	Guida Dx	Right guide
64.23	Carter	Hold Down
64.24.4	Carter Mobile	Movable Hold Down
66.20	Distanziale	Spacer
66.20.1	Distanziale	Spacer
66.22	Distanziale	Spacer
66.23.4	Distanziale	Spacer
71.25	Reggicaricatore	Support
74.24	Staffa	Stirrup
75.33	Sicura	Safety
76.05	Perno	Pin
76.26.4	Perno carter	Pin
77.24	Guida	Guide
77.25	Leva	Lever
81.26	Pistoncino	Piston
86.17.3	Carrucola	Pulley
90.22	Molla	Spring
91.02	Molla	Spring
91.23	Molla	Spring
92.01X	Molla	Spring
93.72.4	Molla	Spring
20.23.24	Battente	Driver
70.23.24	Spingipunto	Pusher
80.23.24	Controtestina	Nose
90.23.17	Testina	Nose plate
D01	Bocchetta olio	Oiler

Guarnizioni - O-Rings - Dichtungen - Joints - Juntas - Δακτύλιος στεγανοποίησης - Vedantes - O-ringen - Contalar - O-ringar - Těsnění - Tesnenia

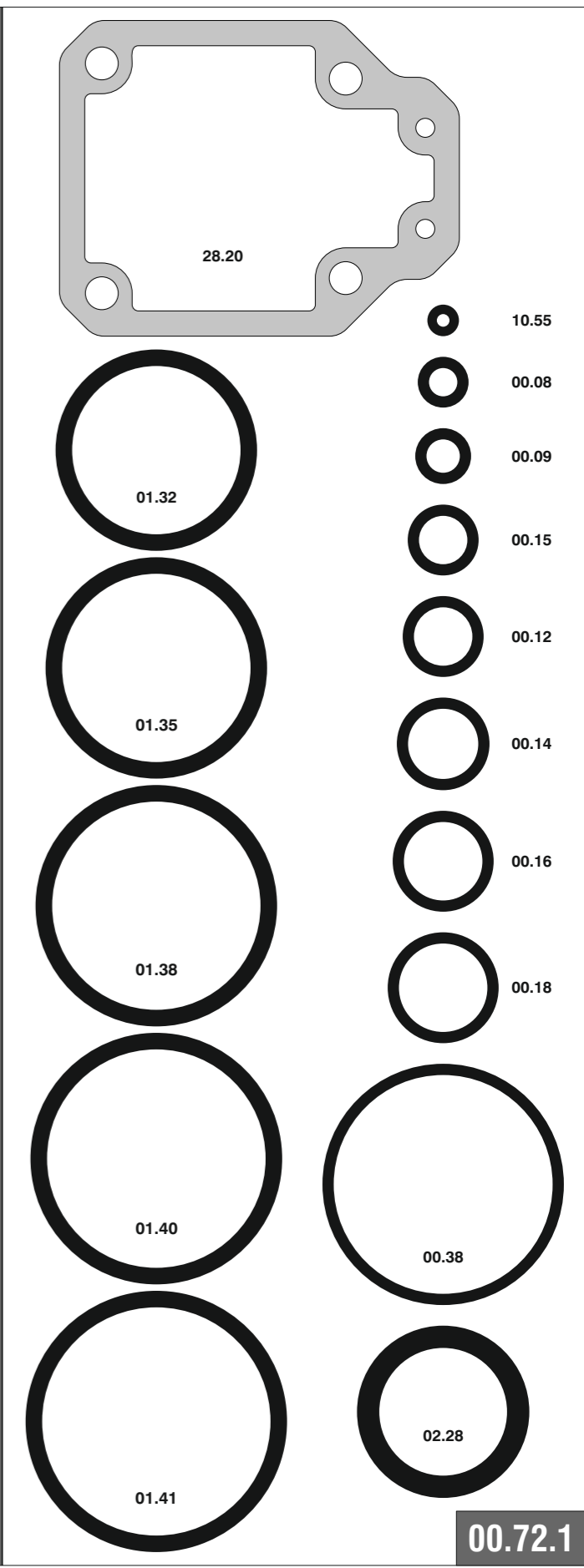

14.25 CLT4

cod. 12214540

Indice di modifica
Upgrade number

2