

Tipo di punto - Type of fastener - Befestigungsmittel - Type de rivet - Tipo de punto - Τύπος αναλωσίμου  
 Tipo de agrafa - Type nietjes - Zimba ve çivi tipleri - Typ av stygn - Typ sponky - Typ spony

590

0,85x1,80

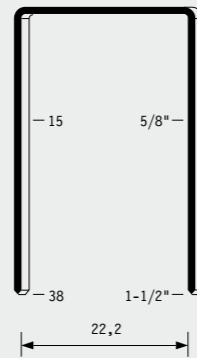

Crown: .941" (15/16")  
 Gauge: 17

Caratteristiche - Features - Merkmale - Caractéristiques - Características  
 Χαρακτηριστικά - Características - Kenmerken - Özellikler - Funktionen - Vlastnosti - Vlastnosti

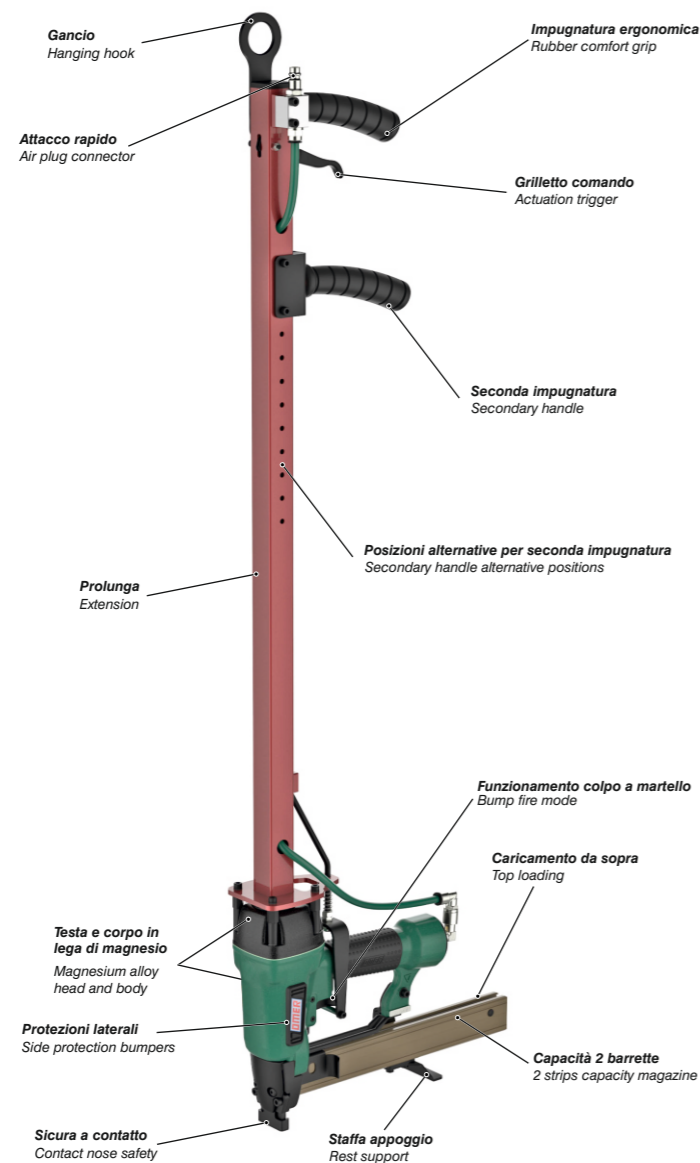

Manuale d'uso, manutenzione e parti di ricambio	Parte 2
Manual for use, maintenance and spare parts	Part 2
Bedienungs- und Wartungshandbuch sowie Ersatzteilleiste	Teil 2
Mode d'emploi, de maintenance et pièces de rechange	Partie 2
Manual de uso, mantenimiento y recambios	Part 2
Εγχειρίδιο χρήσης, συντήρησης και ανταλλακτικών	Μέρος 2
Manual de uso, manutenção e peças sobresselentes	Parte 2
Handleiding voor gebruik, onderhoud en wisselstukken	Deel 2
Kullanım, bakım ve yedek parça kılavuzu	Kisim 2
Användar-, underhålls- och reservdelshandbok	Del 2
Návod k používání a údržbě a náhradní díly	Část 2
Návod na obsluhu, údržbu a náhradné diely	Časť 2

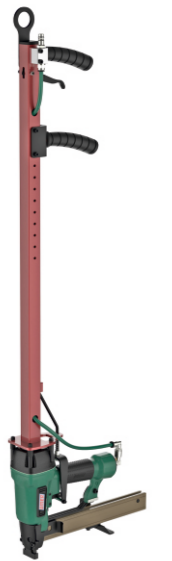

590.738 CP1

cod. 1748710CP1



Dati tecnici Technical data Technische Daten Tehniska data	Caractéristiques techniques Datos técnicos Τεχνικά χαρακτηριστικά Technické údaje	Dados técnicos Technische gegevens Teknik veriler Technické údaje		
<b>Misure impiegabili</b> Lengths Verwendbare Nagellänge Dimensioner som kan användas	Dimensions utiles Medidas de longitud Μήκος Αναλωσίμου Příпустné rozměry	Medidas utilizáveis Toepasbare afmetingen Boy Použitelné rozmery	mm inch	15+40 5/8"÷ 1-1/2"
<b>Capacità caricatore n° punti</b> Magazine capacity Magazinkapazität: Nägel Magasinkapacitet: Antal punkter	Capacité chargeur n° de points Capacidad cargador n° puntos Δυνατότητα γεμιστερά Kapacita zásobníku p. sponek	Capacidade carregador n° pontos Capaciteit magazijn in aantal spijkers Dergi kapasitesi Kapacita zásobníka p. spôn		30
<b>Pressione d'esercizio</b> Operating pressure Betriebsdruck Drifttryck	Pression d'exercice Presión de servicio Πίεση λειτουργίας Pracovní tlak	Pressão de serviço Werkdruk Çalışma basıncı Prevádzkový tlak	bar psi	5÷7,5 70÷105
<b>Consumo aria</b> Air consumption Luftverbrauch Luftförbrukning	Consommation d'air Consumo aire Κατανάλωση αέρα Spotreba vzduchu	Consumo ar Luchtverbruik Hava tüketimi Spotreba vzduchu	lt/colpo ft <sup>3</sup> /cycle	0,75 0,0264
<b>Peso</b> Weight Gewicht Vikt	Poids Peso Βάρος Hmotnost	Peso Gewicht Ağırlık Hmotnost	kg lbs	4,50 9,92
<b>Dimensioni</b> Dimensions Abmessungen Dimensioner (AxBxH)	Dimensions Dimensiones Διαστάσεις Rozměry	Dimensões Afmetingen Boyutlar Rozmery	mm inch	345x85x1120 13-5/8"x3-11/32"x44-1/16" (LxWxH)
<b>EN 12549 :2009 EN ISO 4871 :2009</b> <b>Pressione sonora in pos. operatore</b> Sound pressure in operator's position Schalldruck am Arbeitsplatz Ljudtryck på operatörsplatsen	Pression sonore poste Opérateur Presión sonora en la pos. del operador Ηχητική πίεση στη θέση του χειριστή Akustický tlak v místě obsluhy	Pressão sonora na posição Operador Geluidsdruk op de werkplaats Οπερατόρ ποζιζιονουδα ses basıncı Akustický tlak v mieste obsluhy	dB(A)	86 (K= 4 dB)
<b>EN 12549 :2009 EN ISO 3746 :2011 EN ISO 4871 :2009</b> <b>Potenza sonora emessa</b> Sound power emitted Emitierte Schalleistung Avgiven ljudeffekt	Puissance sonore émise Potencia sonora emitida Εκπεμπόμενη ηχητική ισχύς Emitovaný akustický tlak	Potência sonora emitida Geëmitteerd geluidsvermogen Çıkan ses gücü (ses desibel) Výstupný akustický výkon	dB(A)	94 (K= 4 dB)
<b>CEN ISO/TS 8662-11 :2006 EN ISO 5349-2 :2004 EN 12096 :1999</b> <b>Emissione vibratoria sull'impugnatura</b> Vibratory emissions on handle Emisión de vibraciones en la empuñadura Εκπεμπόμενες δονήσεις στη λαβή Vibrationsemission på handtaget Emise vibrací na rukojet	Émission vibratoire sur la prise en main Emisión de vibraciones en la empuñadura Εκπεμπόμενες δονήσεις στη λαβή Emise vibrací na rukojet	Emissão vibratória na empunhadura Trillingsemisse op de handgreep Tutamaç üzerinde vibrasyon emisyonları Emisie vibrácií na rukováti	m/s <sup>2</sup>	2,6 (K= 2 m/s <sup>2</sup> )

1748710CP1\_590738CP1\_4\_rev22\_27/11/2024\_MG

Parti di ricambio - Spare parts - Ersatzteile - Pièces de rechange - Recambios  
 Ανταλλακτικά - Partes sobresselentes - Wisselstukken - Yedek parçalar - Reservdelar

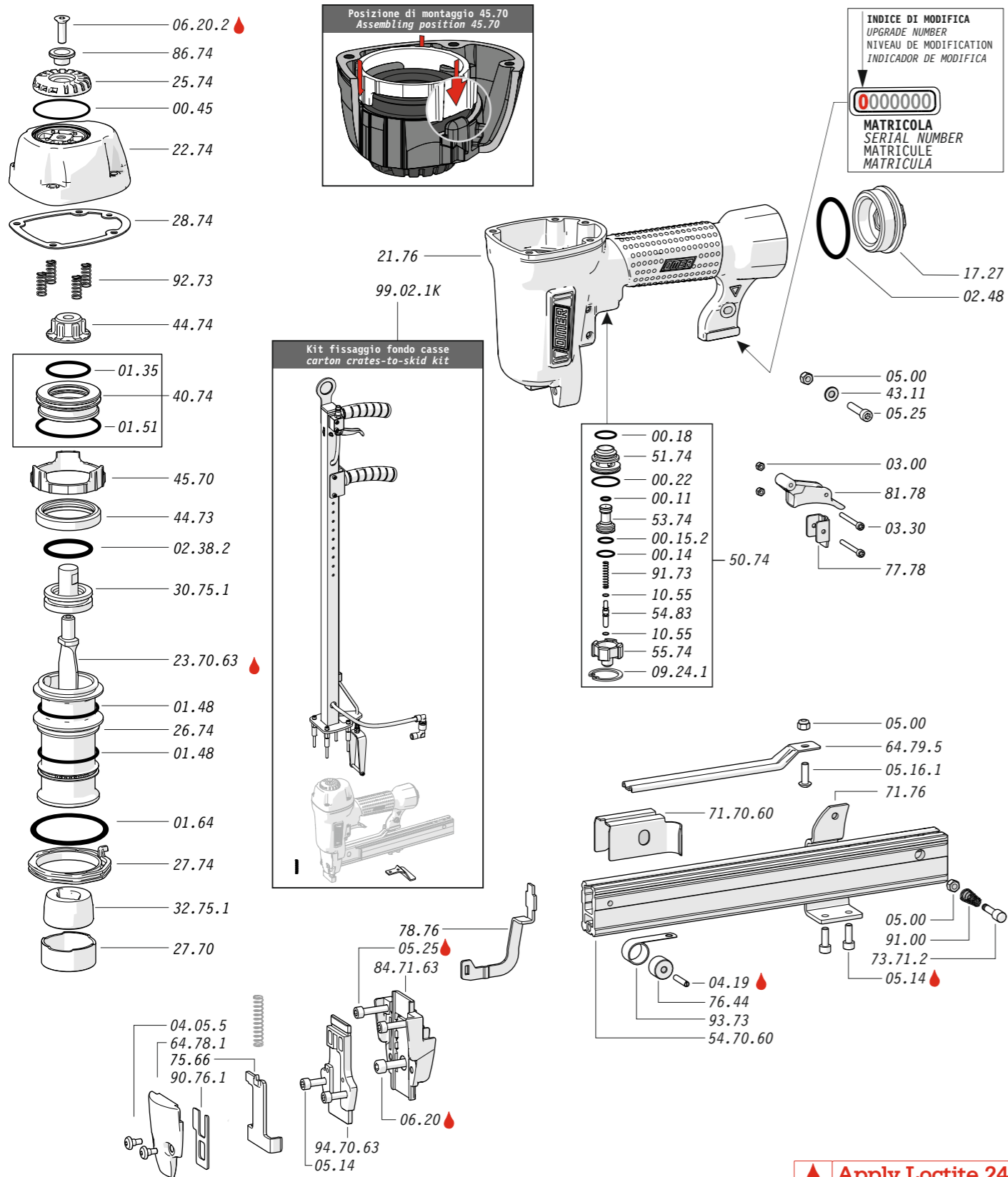

Disincroamento - Jam clearing - Staubeseitigung - Décoincement - Desatascamiento - Απεμπλοκή  
 Desencravamento - Deblokkering bij vastlopen - Sikişma giderme - Rensning av igensättningar - Uvoľnění - Uvoľnenie

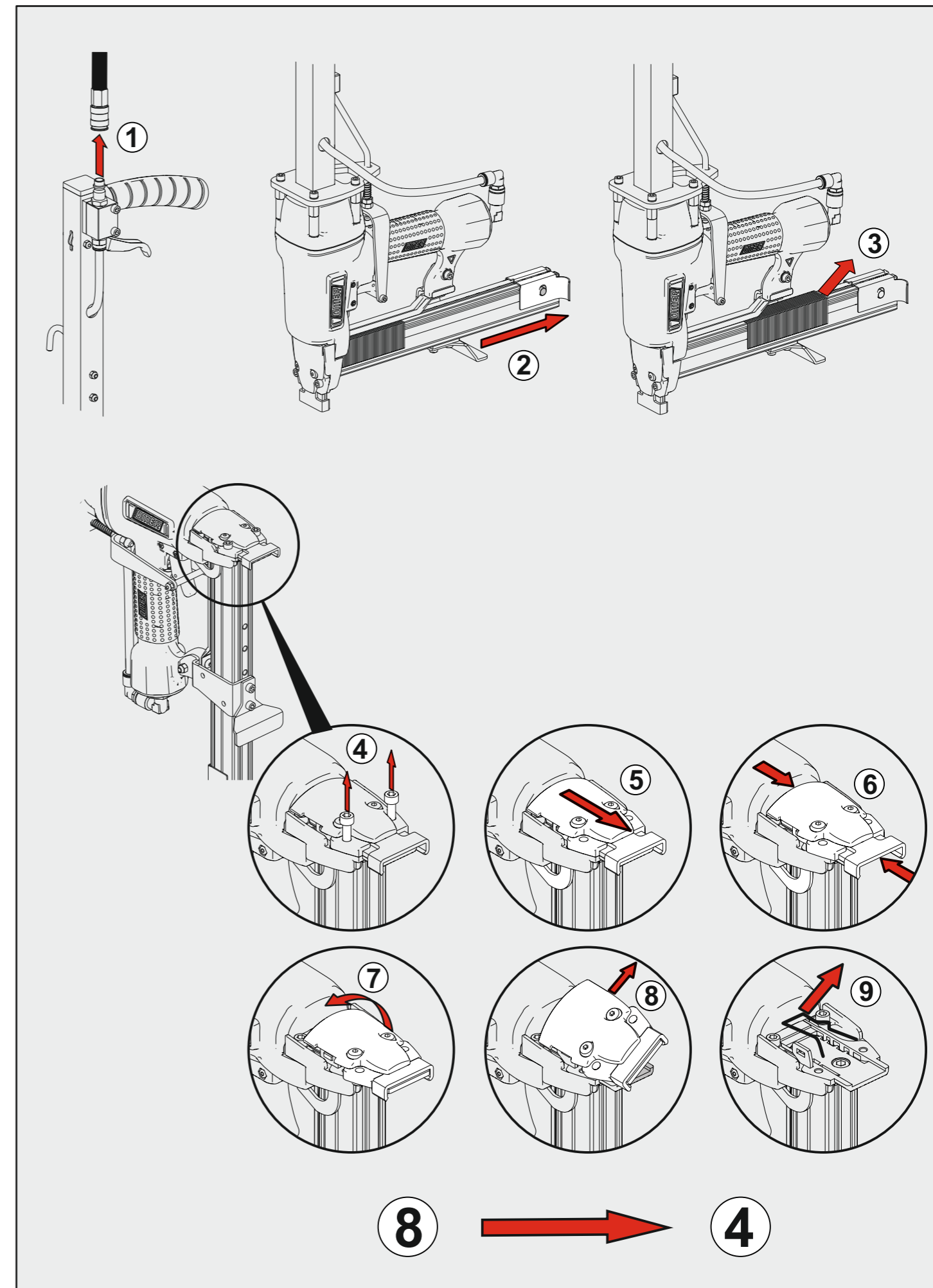

Dotazioni - Equipment - Ausstattung - Outillage - Dotaciones - Εξοπλισμός  
 Dotações - Uitrusting - Donanımlar - Utrustning

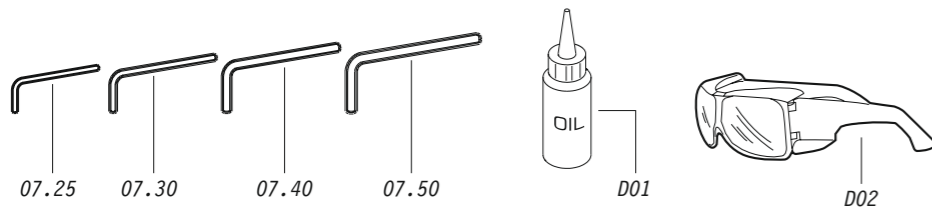

590.738 CP1

cod. 1748710CP1

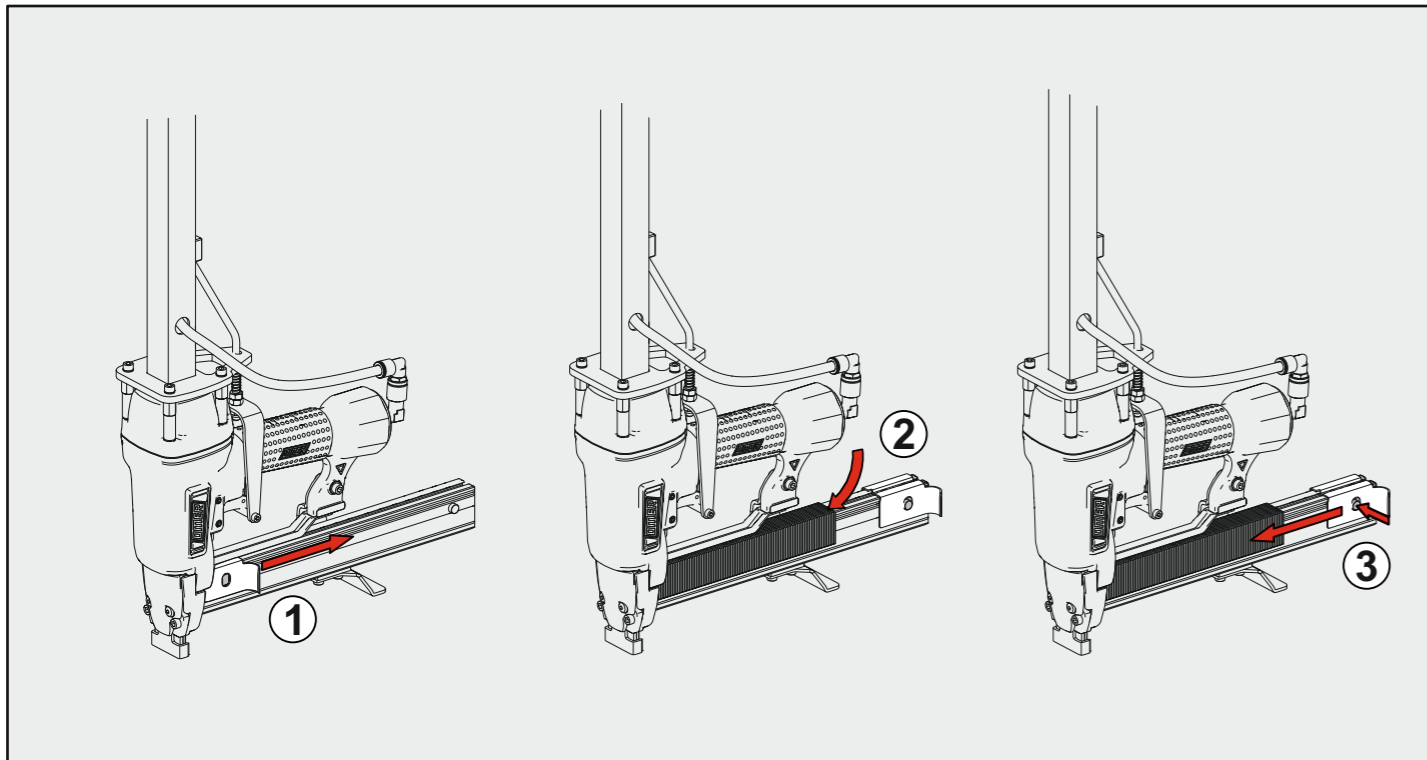

Azionamento - Actuation - Auslösung - Actionnement - Accionamiento - Ενεργοποίηση  
Acionamento - Activering - Çalıştırma - Aktivering - Spuštění - Spustenie

**Azionamento a contatto**  
Contact actuation

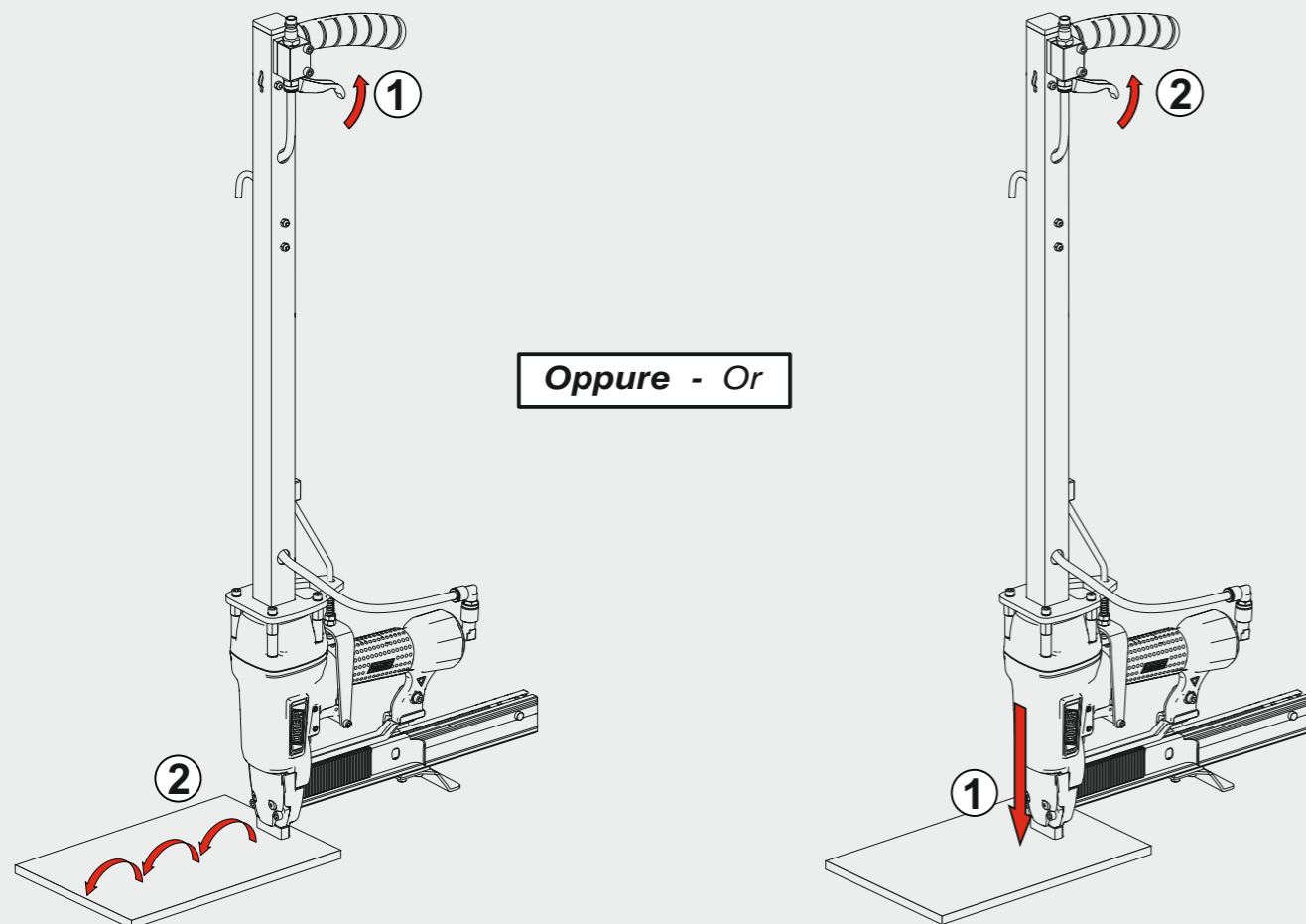

Cod.	Descrizione	Description
00.11	O-Ring	O-Ring
00.14	O-Ring	O-Ring
00.15.2	O-Ring	O-Ring
00.18	O-Ring	O-Ring
00.22	O-Ring	O-Ring
00.45	O-Ring	O-Ring
01.35	O-Ring	O-Ring
01.48	O-Ring	O-Ring
01.51	O-Ring	O-Ring
01.64	O-Ring	O-Ring
02.38.2	O-Ring	O-Ring
02.48	O-Ring	O-Ring
03.00	Dado	Nut
03.30	Dado	Nut
04.05.5	Vite	Screw
04.19	Vite	Screw
05.00	Dado	Nut
05.14	Vite	Screw
05.16.1	Vite	Screw
05.25	Vite	Screw
06.20	Vite	Screw
06.20.2	Vite	Screw
07.25	Chiave esagonale	Hex. bar wrench
07.30	Chiave esagonale	Hex. bar wrench
07.40	Chiave esagonale	Hex. bar wrench
07.50	Chiave esagonale	Hex. bar wrench
09.24.1	Anello elastico	Elastic ring
10.55	O-Ring	O-Ring
17.27	Tappo	Inlet cap
21.76	Corpo	Body
22.74	Testa	Head
25.74	Deflettore scarico	Exhaust deflector
26.74	Cilindro	Cylinder
27.70	Anello	Ring
27.74	Anello cilindro	Cylinder ring
28.74	Guarnizione testa	Head gasket
30.75.1	Pistone	Piston
32.75.1	Ammortizzatore	Bumper
40.74	Valvola completa	Valve assembled
43.11	Rondella	Washer
44.73	Guarnizione cilindro	Cylinder gasket
44.74	Ammortizzatore sup.	Upper bumper
45.70	Distanziale	Spacer
50.74	Pulsante completo	Trigger valve assy
51.74	Boccola servovalvola	Servo valve bushing
53.74	Pistone servovalvola	Servo valve piston
54.83	Pulsante	Trigger valve
55.74	Raccordo pulsante	Trigger valve bush
64.78.1	Carter sicura	Safety guard
64.79.5	Carter	Hold down
71.76	Reggicaricatore	Support
73.71.2	Perno	Pin
75.66	Sicura	Safety
76.44	Rullo molla	Roller
77.78	Guida sicura	Safety guide
78.76	Staffa sicura	Safety rod
81.78	Grilletto comando BF	BF Trigger
86.74	Boccola	Bushing
90.76.1	Piastra	Plate
91.00	Molla	Spring
91.73	Molla	Spring
92.73	Molla	Spring
93.73	Molla	Spring
99.02.1K	Kit fissaggio fondi casse	Crates-to-skid Kit
23.70.63	Battente	Driver
54.70.60	Caricatore	Magazine
71.70.60	Spingipunto	Pusher
84.71.63	Controtestina	Nose
94.70.63	Testina	Nose plate
D01	Bocchetta olio	Oiler
D02	Occhiali protettivi	Protective goggles

Guarnizioni - O-Rings - Dichtungen - Joints - Junta - Δακτύλιος στεγανοποίησης - Vedantes - O-ringen - Contalar - O-ringar - Těsnění - Tesnenia

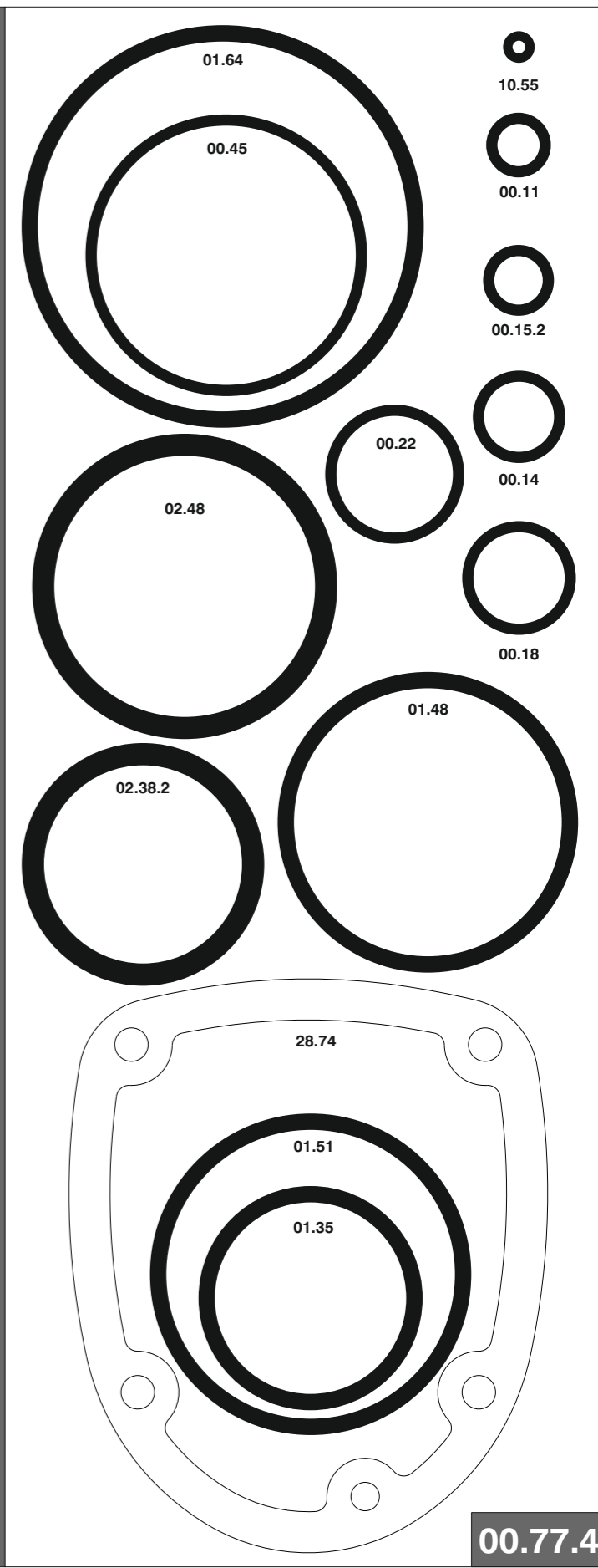

Parti di ricambio - Spare parts - Ersatzteile - Pièces de rechange - Recambios - Ανταλλακτικά  
Partes sobresselentes - Wisselstukken - Yedek parçalar - Reservdelar - Náhradní díly - Náhradné diely

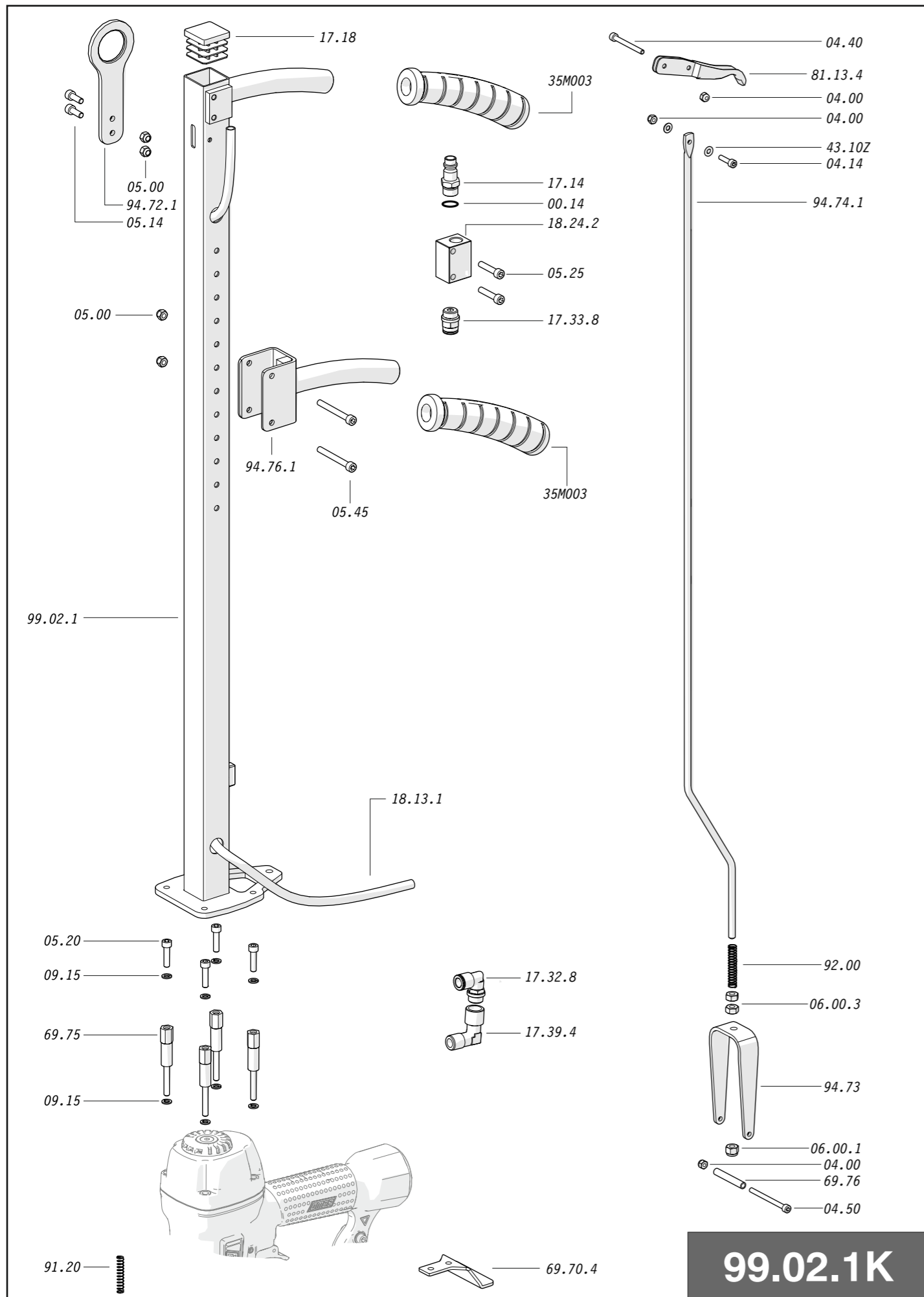

Parti di ricambio - Spare parts - Ersatzteile - Pièces de rechange - Recambios - Ανταλλακτικά  
Partes sobresselentes - Wisselstukken - Yedek parçalar - Reservdelar - Náhradní díly - Náhradné diely

Cod.	Descrizione	Description
00.14	O-Ring	O-Ring
04.00	Dado	Nut
04.14	Vite	Screw
04.40	Vite	Screw
04.50	Vite	Screw
05.00	Dado	Nut
05.14	Vite	Screw
05.20	Vite	Screw
05.25	Vite	Screw
05.45	Vite	Screw
06.00.1	Dado	Nut
06.00.3	Dado	Nut
09.15	Rondella	Washer
17.14	Attacco rapido	Air plug
17.18	Tappo	Inlet cap
17.32.8	Raccordo "L"	Connection "Elbow"
17.33.8	Raccordo "D"	Connection "Straight"

Cod.	Descrizione	Description
17.39.4	Raccordo "L"	Connection "Elbow"
18.24.2	Distributore	Distributor
18.13.1	Tube	Tube
43.10Z	Rondella	Washer
69.70.4	Staffa appoggio	Rest support
69.75	Vite-distanziale	Spacer-screw
69.76	Distanziale	Spacer
81.13.4	Grilletto	Trigger
91.20	Molla	Spring
92.00	Molla	Spring
94.72.1	Gancio	Hook
94.73	Forcella	Fork
94.74.1	Tirante	Rod
94.76.1	Maniglia	Handle
99.02.1	Prolunga	Extension
35M003	Impugnatura gomma	Rubber grip

Dati tecnici - Technical data - Technische Daten - Caractéristiques techniques - Datos técnicos - Τεχνικά χαρακτηριστικά  
Datos técnicos - Technische gegevens - Teknik veriler - Tekniska data - Technické údaje - Technické údaje

