

ROLL C

0,95x1,90

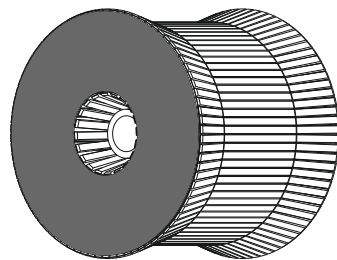
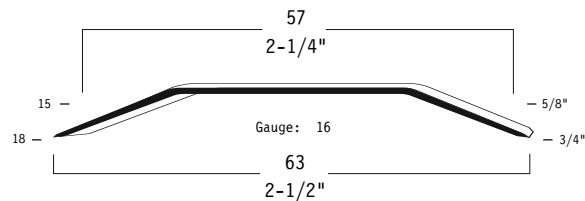
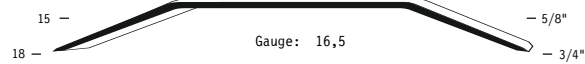

Caricamento - Loading - Laden - Chargement - Carga - Γέμισμα - Carregamento - Laden - Yükleme

Caricamento da sopra Top load magazine

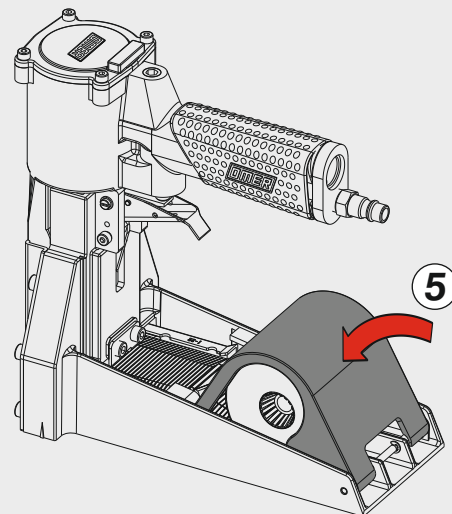
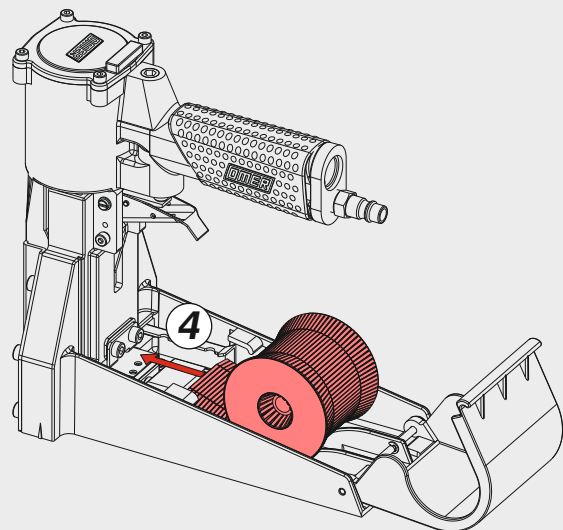
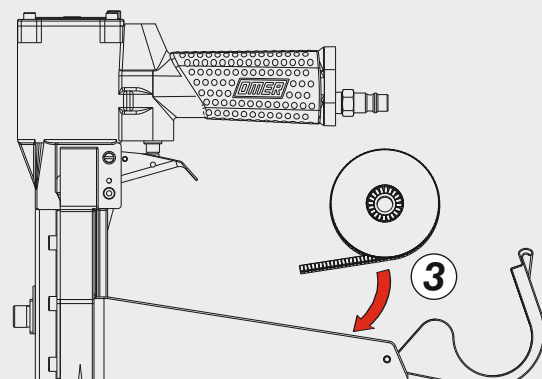
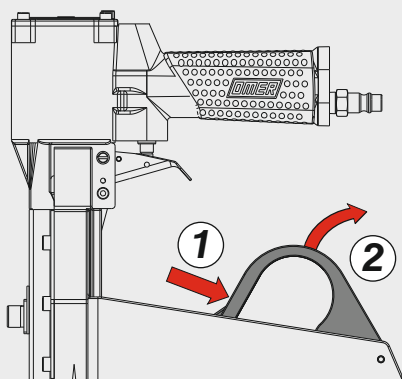

Manuale d'uso, manutenzione e parti di ricambio	Parte 2
Manual for use, maintenance and spare parts	Part 2
Bedienungs- und Wartungshandbuch sowie Ersatzteilleiste	Teil 2
Mode d'emploi, de maintenance et pièces de rechange	Partie 2
Manual de uso, mantenimiento y recambios	Part 2
Εγχειρίδιο χρήσης, συντήρησης και ανταλλακτικών	Μέρος 2
Manual de uso, manutenção e peças sobresselentes	Parte 2
Handleiding voor gebruik, onderhoud en wisselstukken	Deel 2
Kullanım, bakım ve yedek parça kılavuzu	Kısım 2

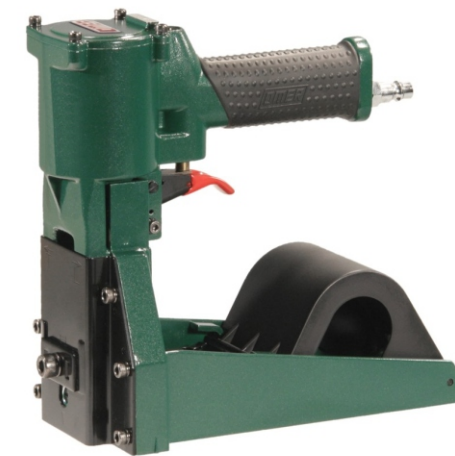

C.18 Roll

cod. 19718RT4



Dati tecnici Technical data Technische Daten	Caractéristiques techniques Datos técnicos Τεχνικά χαρακτηριστικά	Dados técnicos Technische gegevens Teknik veriler
Misure impiegabili mm Lengths mm Verwendbare Nagellänge mm	Dimensions utiles mm Medidas de longitud mm Μήκος Αναλωσίμου - mm	Medidas utilizáveis mm Toepasbare afmetingen mm Boy mm
		15 ÷ 18
Capacità caricatore n° punti Magazine capacity Magazinkapazität Nägel	Capacité chargeur n° de points Capacidad cargador n° puntos Δωνατοτητα γεμιστερα	Capacidade carregador n° pontos Capaciteit magazijn in aantal spijkers Dergi kapasitesi
		1000
Pressione d'esercizio Operating pressure Betriebsdruck	Pression d'exercice Presión de servicio Πίεση λειτουργίας	Pressão de serviço Werkdruk Çalışma basıncı
		5 ÷ 7 bar 70 ÷ 100 psi
Consumo aria litri/colpo Air consumption litres/stroke Luftverbrauch Liter/Schuss	Consommation d'air litres/coup Consumo aire litros/golpe Κατανάλωση αέρα - λίτρα/βολή	Consumo ar litros/disparo Luchtverbruik liter/slag Litre/vuruş hava tüketimi
		1,32
Peso kg Weight kg Gewicht kg	Poids kg Peso kg Βάρος - kg	Peso kg Gewicht in kg Ağırlık kg
		2,40
Dimensioni mm Dimensions mm Abmessungen mm	Dimensions mm Dimensiones mm Διαστάσεις mm	Dimensões mm Afmetingen mm Boyutlar mm
		237x115x222 (LxWxH)
UNI EN 12549 :2009 UNI EN ISO 4871 :2009		
Pressione sonora in pos. operatore Sound pressure in operator's position Schalldruck am Arbeitsplatz	Pression sonore poste Opérateur Presión sonora en la pos. del operador Ηχητική πίεση στη θέση του χειριστή	Pressão sonora na posição Operador Geluidsdruk op de werkplaats Operatör pozisyonunda ses basıncı
		89 dB(A) (K= 2,5 dB)
UNI EN 12549 :2009 UNI EN ISO 3746 :2011 UNI EN ISO 4871 :2009		
Potenza sonora emessa Sound power emitted Emittierte Schallleistung	Puissance sonore émise Potencia sonora emitida Εκπεμπόμενη ηχητική ισχύς	Potência sonora emitida Geëmitteerd geluidsvermogen Çıkan ses gücü (ses desibel)
		93 dB(A) (K= 2,5 dB)
UNI CEN ISO/TS 8662-11 :2006 UNI EN ISO 5349-2 :2004 UNI EN 12096 :1999		
Emissione vibratoria sull'impugnatura Vibratory emissions on handle Vibrationsemission am Griff	Émission vibratoire sur la prise en main Emisión de vibraciones en la empuñadura Εκπεμπόμενες δονήσεις στη λαβή	Emissão vibratória na empunhadura Trillingsemissie op de handgreep Tutamak üzerinde vibrasyon emisyonları
		<2,5 m/s² (K= 0,62 m/s ³)

Parti di ricambio - Spare parts - Ersatzteile - Pièces de rechange - Recambios
 Ανταλλακτικά - Partes sobresselentes - Wisselstukken - Yedek parçalar

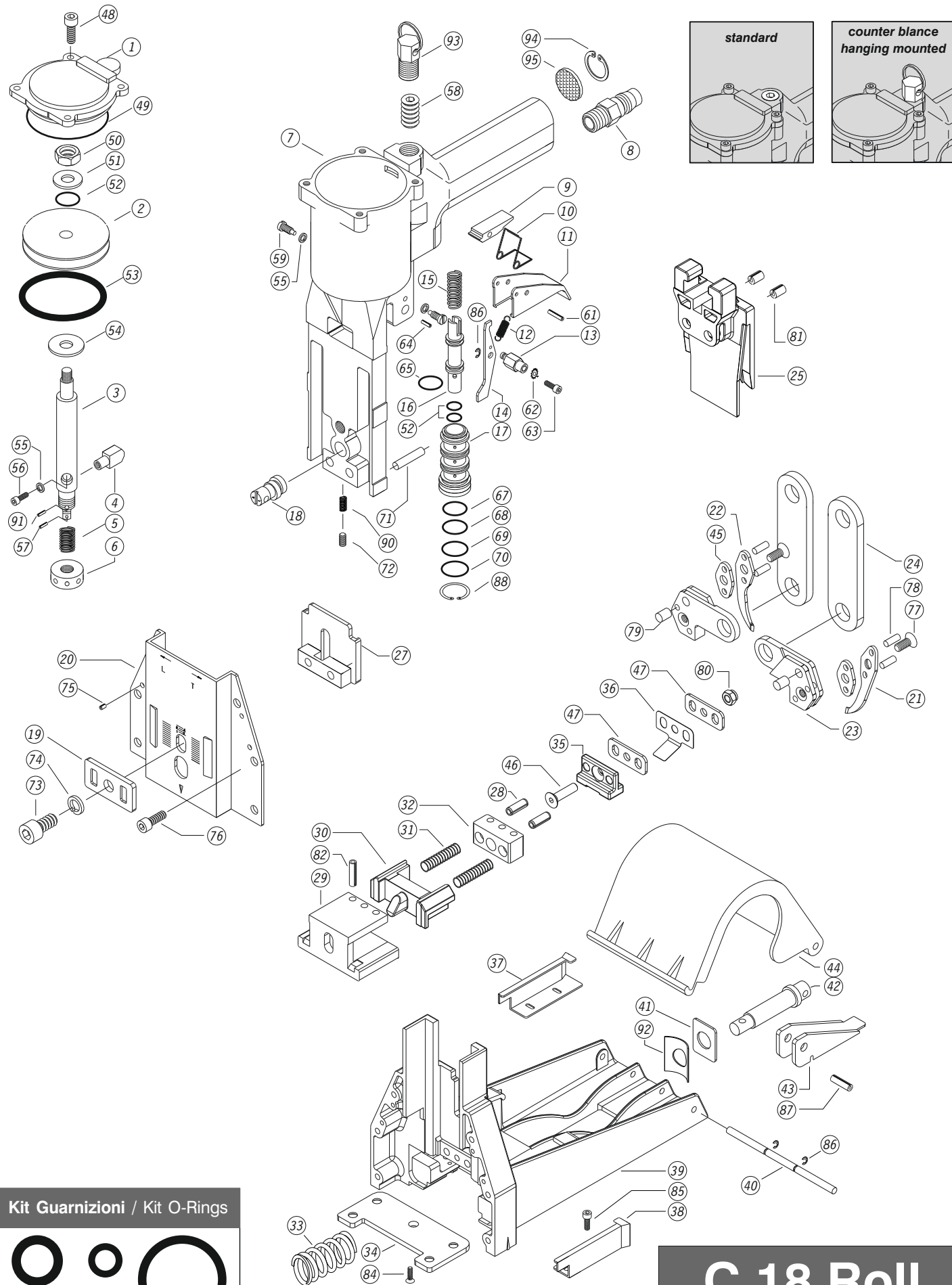

C.18 Roll

cod. 19718RT4

Kit Guarnizioni / Kit O-Rings

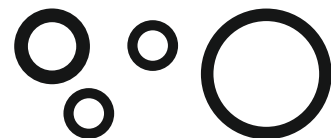

CRT0RK1

Regolazione della chiusura - Clinching adjustment

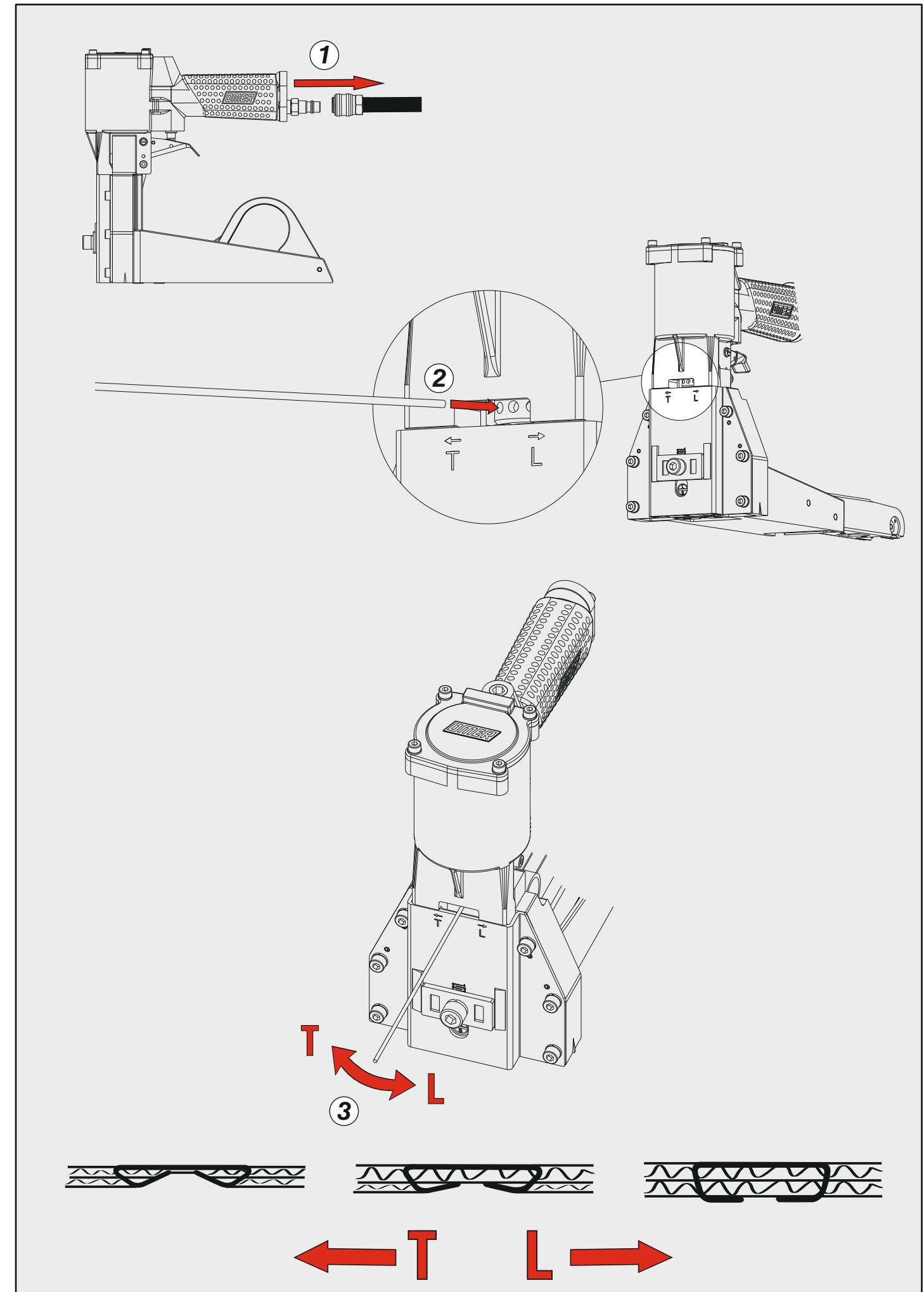

Regolazione di profondità - Depth adjustment - Tiefeneinstellung - Réglage des dimensions - Réglage des dimensions
 Ρύθμιση βάθους - Regulação de profundidade - Diepte afstelling - Derinlik ayarı

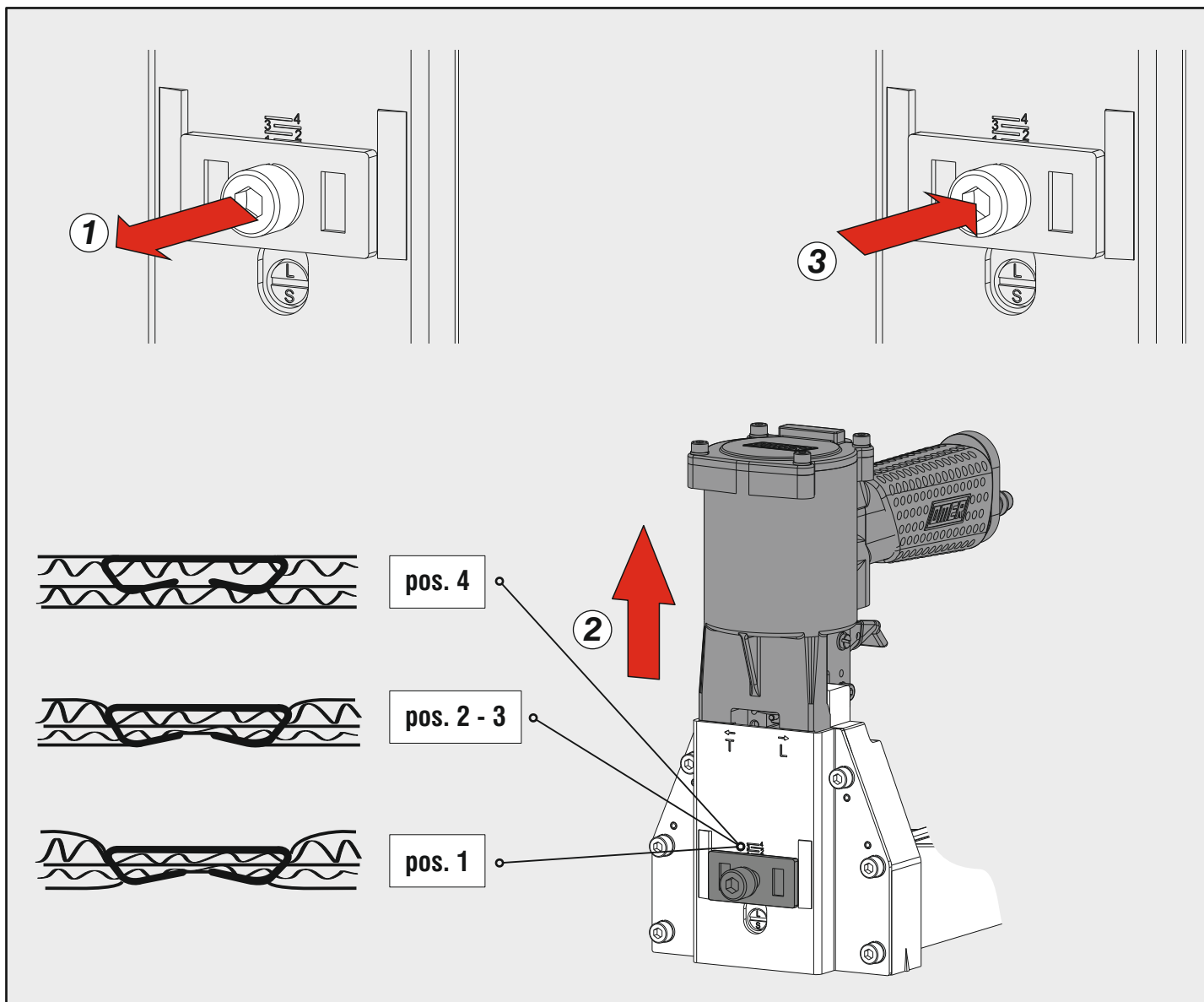

Azionamento - Actuation - Auslösung - Actionnement - Accionamiento - Ενεργοποίηση - Acionamento - Activering - Çalıştırma

Azionamento singolo
 Single actuation

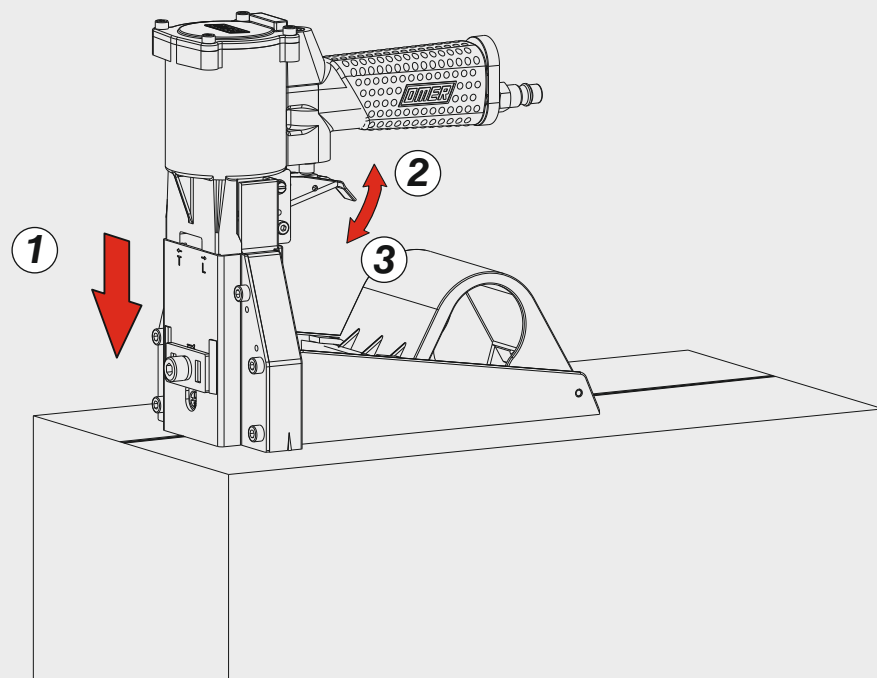

Ref. No.	Part No.	Description	Ref. No.	Part No.	Description	Ref. No.	Part No.	Description
1	32P501	Cap	34	19R034	Plate	68	35P059	O-Ring
2	35P002N	Piston	35	35R035	Top Guide	69	35P060	O-Ring
3	35P003N	Piston Rod	36	35R036	Leaf Spring	70	35P061	O-Ring
4	35P004	Block	37	19I037	Right Coil Guide	71	35P062	Rod
5	35P005	Spring	38	19I038	Left Coil Guide	72	35P063	Screw
6	35P006	Collar	39	32R039	Magazine Seat	73	35P064	Screw
7	35P007N	Body	40	19R040	Shaft	74	35P065	Spring Washer
8	35P008	Air Plug	41	19T041	Washer	75	35P066	Spring Pin
9	35P009	Block	42	19R042	Shaft	76	32P570	Screw
10	35P010	Spring	43	19R043	Lever	77	35P069	Screw
11	35P011	Trigger	44	19R044	Cover	78	35P070	Pin
12	35P012	Spring	45	35P092	Plate	79	35P071	Pin
13	35P013	Rod	46	35R540	Screw	80	35R531	Nut
14	35P014	Trigger's control	47	35R047	Washer	81	35P072	Spring Pin
15	35P015	Spring	48	35P040N	Screw	82	19B081	Spring Pin
16	35P016	Valve	49	35P042N	O-Ring	84	35P082N	Screw
17	35P017N	Tube	50	35P043	Nut	85	19B084	Screw
18	35P018	Adjusting Rod	51	35P044	Washer	86	35P081	E-Ring
19	35P019	Adjusting Plate	52	35P045	O-Ring	87	19B086	Spring Pin
20	32P520	Front plate	53	35P046N	O-Ring	88	35P080N	C-Ring
21	35P021	Right jaw	54	35P047	Washer	90	35P084	Heli-Coil
22	35P022	Left jaw	55	35P041	Spring Washer	91	35P085	Plastic Pin
23	35P023	Jaw seat	56	35P048	Screw	92	19B090	Wave Washer
24	35P024	Plate	57	35P049	Spring Pin	93	19B091	Counter Balance Hanger
25	35T025	Driver	58	35P050	Screw	94	35P080N	C-Ring
27	35T027	Driver guide unit	59	35P051	Trigger Screw	95	32P541	Silencer
28	35R528	Spring pin	61	35P052	Spring Pin	07.25		Hex. Bar wrench
29	19I029	Anvil	62	35P053	Teeth Washer	07.30		Hex. Bar wrench
30	32R030	Pusher	63	35P054	Screw	07.40		Hex. Bar wrench
31	19R031	Spring	64	35P066	Spring Pin	D01		Oiler
32	19R032	Anvil Cap	65	35P056	O-Ring	D06		Staple remover
33	19R033	Spring	67	35P058	O-Ring			

Dotazioni - Equipment - Ausstattung - Outillage - Dotaciones - Εξοπλισμός
 Dotações - Uitrusting - Donanımlar

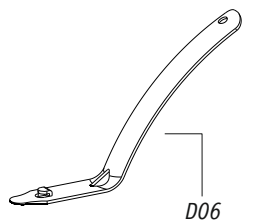
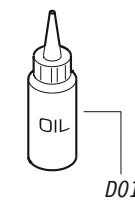

C.18 Roll

cod. 19718RT4

Indice di modifica
 Upgrade number

4

