

Azionamento singolo
Single actuation

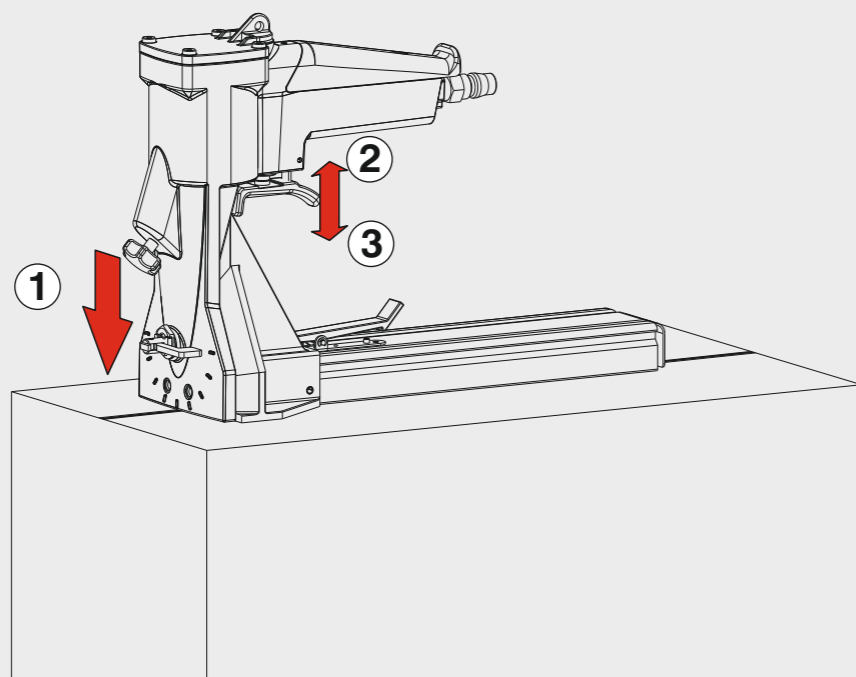

Caricamento - Loading - Laden - Chargement - Carga - Γέμισμα - Carregamento - Laden - Yükleme

Caricamento da sopra
Top load magazine

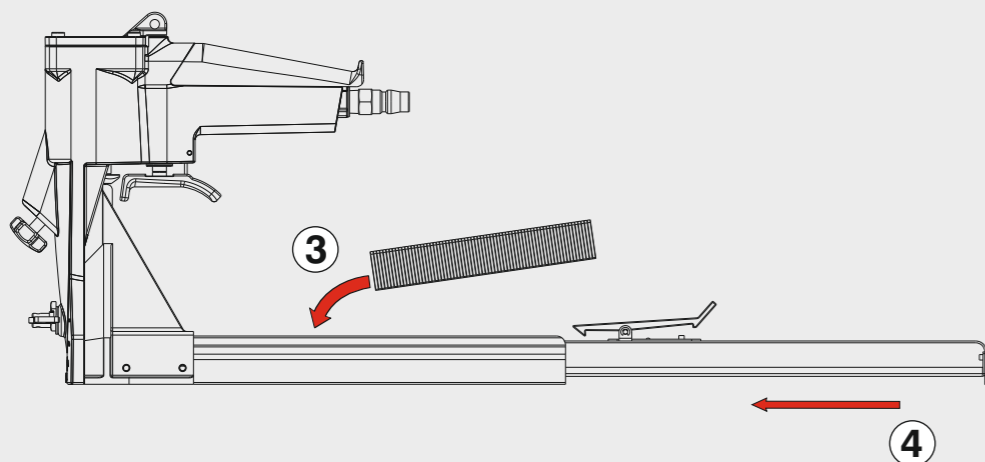
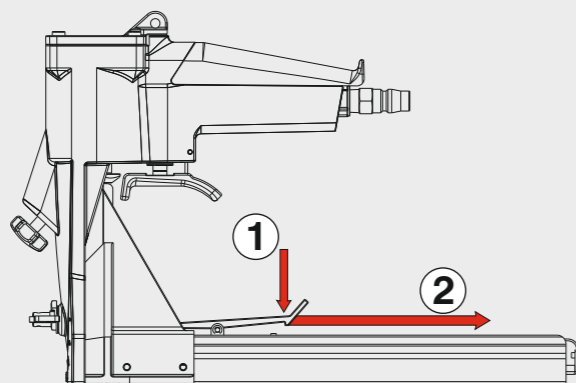

Manuale d'uso, manutenzione e parti di ricambio	Parte 2
Manual for use, maintenance and spare parts	Part 2
Bedienungs- und Wartungshandbuch sowie Ersatzteilleiste	Teil 2
Mode d'emploi, de maintenance et pièces de rechange	Partie 2
Manual de uso, mantenimiento y recambios	Part 2
Εγχειρίδιο χρήσης, συντήρησης και ανταλλακτικών	Μέρος 2
Manual de uso, manutençao e peças sobresselentes	Parte 2
Handleiding voor gebruik, onderhoud en wisselstukken	Deel 2
Kullanım, bakım ve yedek parça kılavuzu	Kısım 2



32.18 E

cod. 197M3218E



Dati tecnici Technical data Technische Daten	Caractéristiques techniques Datos técnicos Τεχνικά χαρακτηριστικά	Dados técnicos Technische gegevens Teknik veriler
Misure impiegabili mm Lengths mm Verwendbare Nagellänge mm	Dimensions utiles mm Medidas de longitud mm Μήκος Αναλωσίμου - mm	Medidas utilizáveis mm Toepasbare afmetingen mm Boy mm
		15 ÷ 18
Capacità caricatore n° punti Magazine capacity Magazinkapazität Nägel	Capacité chargeur n° de points Capacidad cargador n° puntos Δωνατοτητα γεμιστερα	Capacidade carregador n° pontos Capaciteit magazijn in aantal spijkers Dergi kapasitesi
		120
Pressione d'esercizio Operating pressure Betriebsdruck	Pression d'exercice Presión de servicio Πίεση λειτουργίας	Pressão de serviço Werkdruk Çalışma basıncı
		5 ÷ 7 bar 70 ÷ 100 psi
Consumo aria litri/colpo Air consumption litres/stroke Luftverbrauch Liter/Schuss	Consommation d'air litres/coup Consumo aire litros/golpe Κατανάλωση αέρα - λίτρα/βολή	Consumo ar litros/disparo Luchtverbruik liter/slag Litre/vuruş hava tüketimi
		1,11
Peso kg Weight kg Gewicht kg	Poids kg Peso kg Βάρος - kg	Peso kg Gewicht in kg Ağırlık kg
		1,63
Dimensioni mm Dimensions mm Abmessungen mm	Dimensions mm Dimensiones mm Διαστάσεις mm	Dimensões mm Afmetingen mm Boyutlar mm
		313x100x205 (LxWxH)
UNI EN 12549 :2009 UNI EN ISO 4871 :2009		
Pressione sonora in pos. operatore Sound pressure in operator's position Schalldruck am Arbeitsplatz	Pression sonore poste Opérateur Presión sonora en la pos. del operador Ηχητική πίεση στη θέση του Χειριστή	Pressão sonora na posição Operador Geluidsdruk op de werkplaats Operatör pozisyonunda ses basıncı
		84,3 dB(A) (K= 2,5 dB)
UNI EN 12549 :2009 UNI EN ISO 3746 :2011 UNI EN ISO 4871 :2009		
Potenza sonora emessa Sound power emitted Emittierte Schallleistung	Puissance sonore émise Potencia sonora emitida Εκπεμπόμενη ηχητική ισχύς	Potência sonora emitida Geëmitteerd geluidsvermogen Çıkan ses gücü (ses desibel)
		93,7 dB(A) (K= 2,5 dB)
UNI CEN ISO/TS 8662-11 :2006 UNI EN ISO 5349-2 :2004 UNI EN 12096 :1999		
Emissione vibratoria sull'impugnatura Vibratory emissions on handle Vibrationsemission am Griff	Émission vibratoire sur la prise en main Emisión de vibraciones en la empuñadura Εκπεμπόμενες δονήσεις στη λαβή	Emissão vibratória na empunhadura Trillingsemissie op de handgreep Tutamak üzerinde vibrasyon emisyonları
		<2,5 m/s² (K= 0,61 m/s ³)

Tipo di punto
Type of fastener
Befestigungsmittel
Type de rivet
Tipo de punto
Τύπος αναλωσίμου
Tipo de agrafo
Type nietjes
Zimba ve çivi tipleri

32

0,80x1,90

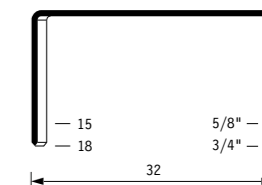

Gauge: 16,5

Crown: 1.260° (1-1/4°)

Parti di ricambio - Spare parts - Ersatzteile - Pièces de rechange - Recambios
 Ανταλλακτικά - Partes sobresselentes - Wisselstukken - Yedek parçalar

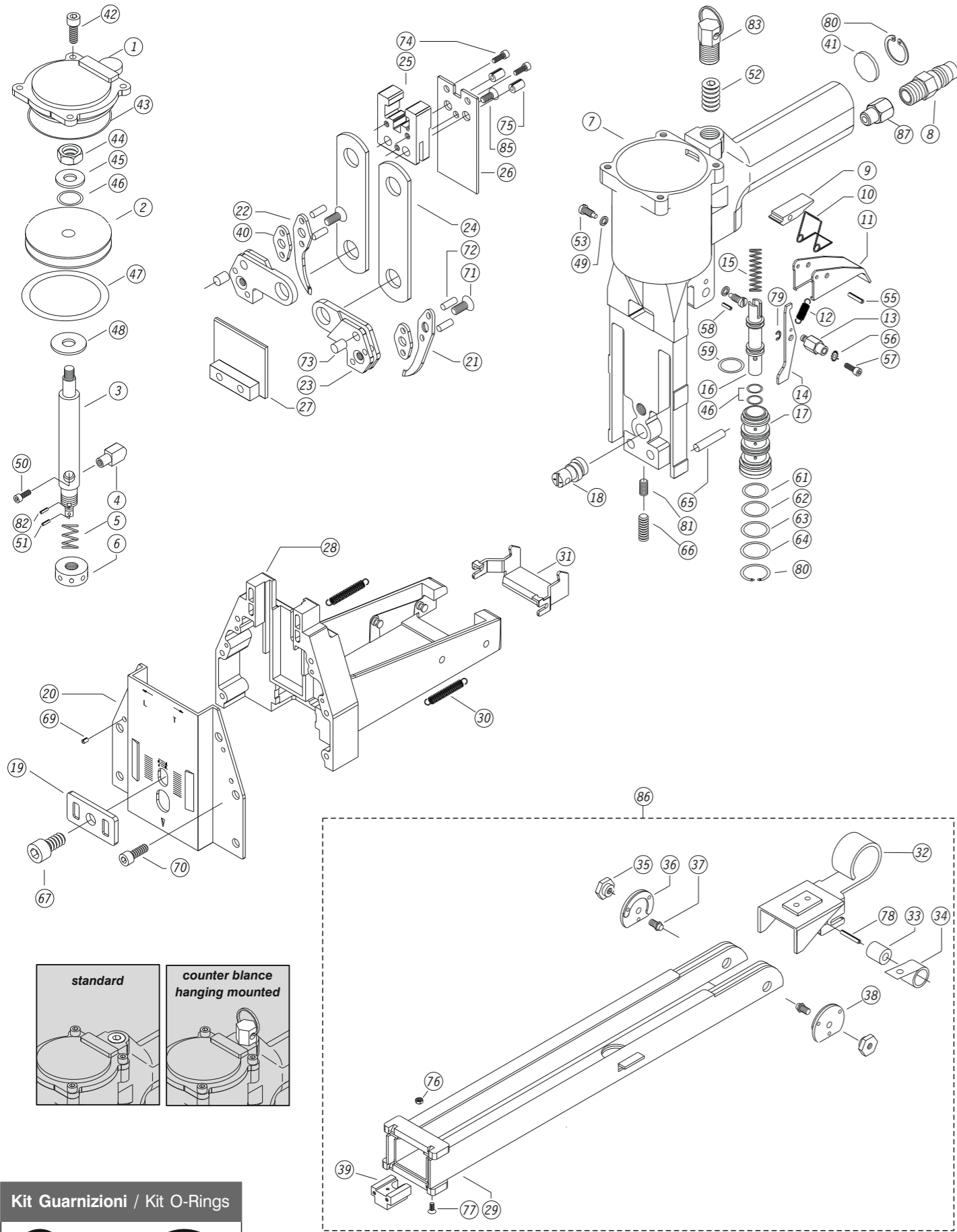

Kit Guarnizioni / Kit O-Rings

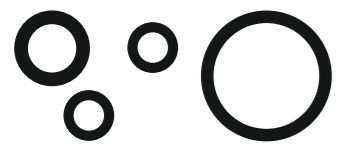

CRT0RK1

32.18

cod. 19718T3

Regolazione della chiusura - *Clinching adjustment*

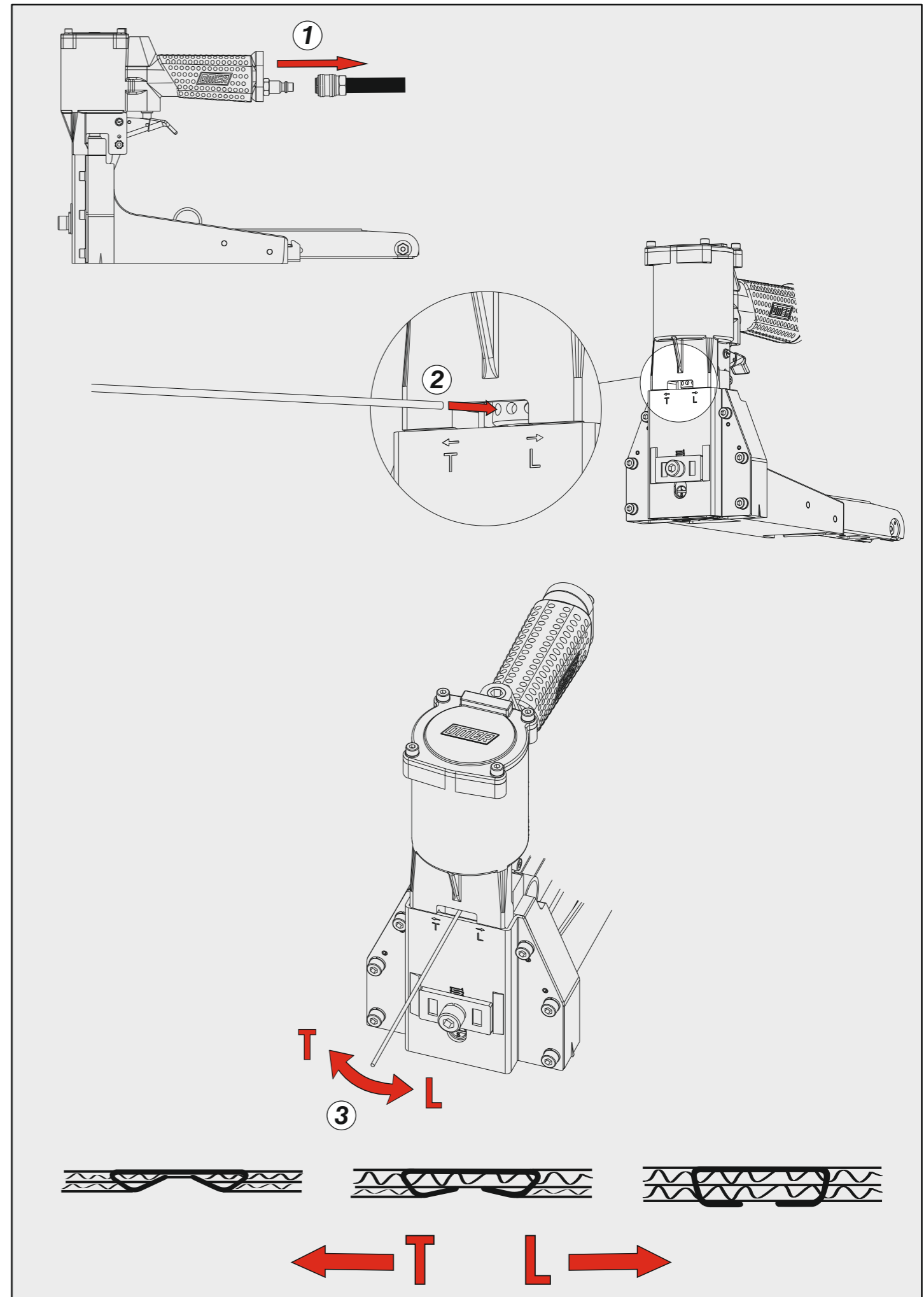

Regolazione di profondità - Depth adjustment - Tiefeneinstellung - Réglage des dimensions - Réglage des dimensions
 Ρύθμιση βάθους - Regulação de profundidade - Diepte afstelling - Derinlik ayarı

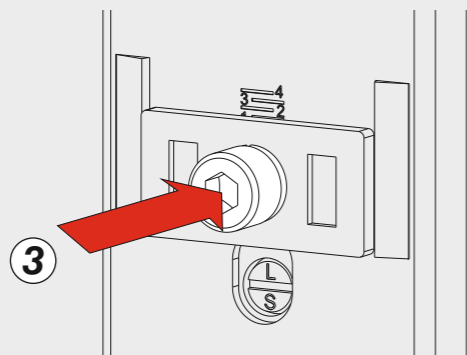
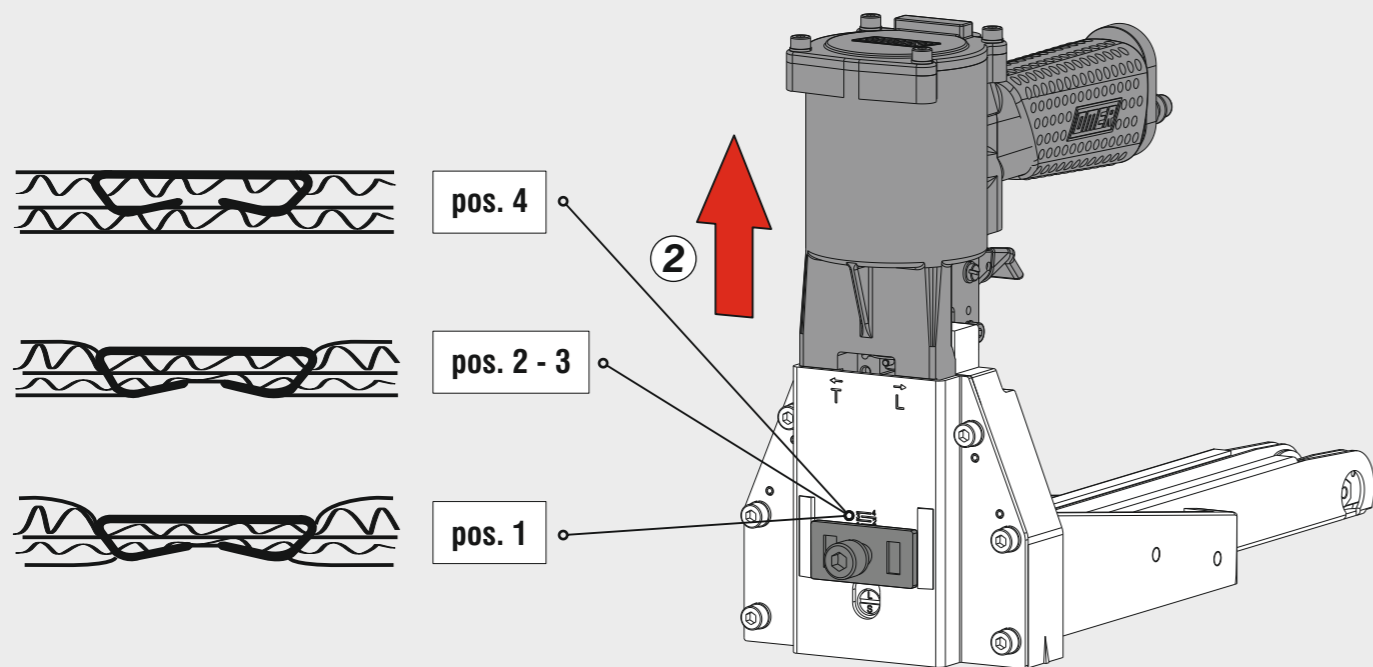
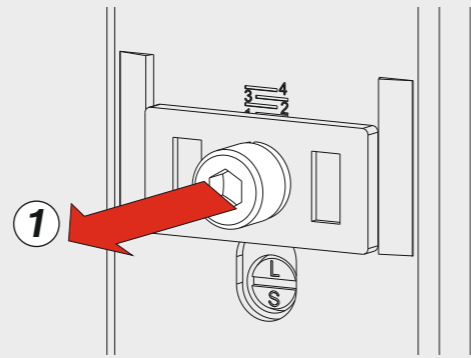
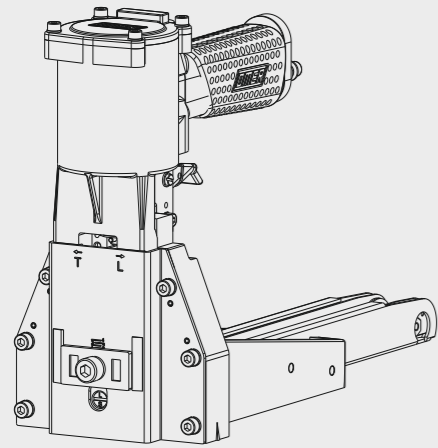

Ref. No.	Part No.	Description	Ref. No.	Part No.	Description	Ref. No.	Part No.	Description
1	32P501	Cap	31	32M523	Bracket	63	35P060	O-Ring
2	35P002N	Piston	32	32P035	Pusher Unit	64	35P061	O-Ring
3	35P003N	Piston Rod	33	35P034	Roller	65	35P062	Rod
4	35P004	Block	34	35P033	Spring	66	35P063	Screw
5	35P005	Spring	35	32P535	Rod Nut	67	35P064	Screw
6	35P006	Collar	36	35P037	Right pusher guide	69	35P066	Spring Pin
7	35P007N	Body	37	35P032	Rod	70	32P570	Screw
8	35P008	Air Plug	38	35M032	Left pusher guide	71	35P069	Screw
9	35P009	Block	39	34P339	Bracket	72	35P070	Pin
10	35P010	Spring	40	35P039	Washer	73	35P071	Pin
11	35P011	Trigger	41	32P541	Silencer	74	35M046N	Screw
12	35P012	Spring	42	35P040N	Screw	75	35P072	Spring Pin
13	35P013	Rod	43	35P042N	O-Ring	76	35P076	Lock nut
14	35P014	Trigger's Control	44	35P043	Nut	77	32P577	Screw
15	35P015	Spring	45	35P044	Washer	78	32M549	Spring Pin
16	35P016	Valve	46	35P045	O-Ring	79	35P081	E-Ring
17	35P017N	Tube	47	35P046N	O-Ring	80	35P080N	C-Ring
18	35P018	Adjusting Rod	48	35P047	Washer	81	35P084	Heli-Coil
19	35P019	Adjusting Plate	49	35P041	Spring Washer	82	35P085	Plastic Pin
20	32P520	Front plate	50	35P048	Screw	83	19B091	Counter Balance Hanger
21	35P021	Right jaw	51	35P049	Spring Pin	85	32P585	Screw
22	35P022	Left jaw	52	35P050	Screw	86	32M321	Magazine Ass'y
23	35P023	Jaw seat	53	35P051	Trigger Screw	87	34P387	Adaptor
24	35P024	Plate	55	35P052	Spring Pin	07.25		Hex. Bar wrench
25	32P525	Block	56	35P053	Teeth Washer	07.30		Hex. Bar wrench
26	32M518	Driver	57	35P054	Screw	07.40		Hex. Bar wrench
27	35P027	Cover Unit	58	35P066	Spring Pin	D01		Oiler
28	32M320	Magazine seat	59	35P056	O-Ring	D06		Staple remover
29	32P329	Magazine	61	35P058	O-Ring			
30	32M522	Spring	62	35P059	O-Ring			

Dotazioni - Equipment - Ausstattung - Outillage - Dotaciones - Εξοπλισμός
 Dotações - Uitrusting - Donanımlar

