

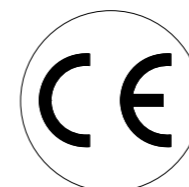

192HR23MA2_HR23M8_291013 IV



**Manuale d'uso, manutenzione
e parti di ricambio Parte 2**
Use, maintenance
and spare parts manual Part.2

HR23 M8

cod. 192HR23MA2

Indice di modifica
Upgrade number

A2

Misure impiegabili mm (inch) Usable lengths mm (inch)	23 (7/8")
Capacità caricatore n° punti Magazine capacity No. of fasteners	130
Pressione d'esercizio bar (psi) Working pressure bar (psi)	5 ÷ 7 (70 ÷ 100)
Consumo aria litri/colpo a 6 bar Air consumption litres/shot at 6 bar	1,50
Peso kg Weight kg	1,45
Dimensioni (AxBxH) mm Dimensions mm	198x89x354
EN 12549:1999 ISO 11201:1995 Pressione sonora in posizione operatore Max A-Weighted pressure level at operator's position	84 dBA
EN 12549:1999 ISO 3744:1994 Potenza sonora emessa Max A-Weighted sound power level	94 dBA
ISO 8662-11:1999 Vibrazione Vibration	< 2,5 m/s²

Dimensione naso
Nose dimension

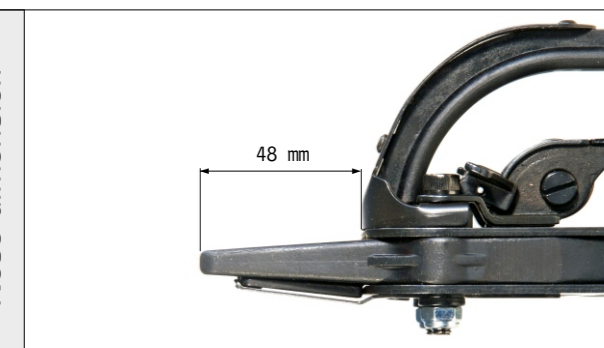

Tipo di punto
Type of fastener

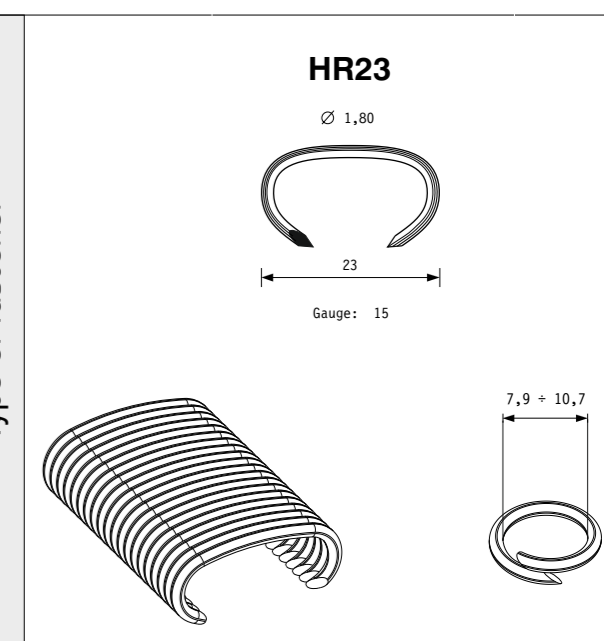

Ref. No. Part No. Description

001	2HR23M-A001	Testa	Head
002	2HR23M-A002	Guarnizione testa	Head gasket
003	2HR20M-A003	Pistone	Piston
004	2HR23M-B004	Corpo	Body
005	2HR23M-A005	Deflettore	Deflector
006	2HR23M-B006	Valvola posteriore	Rear Valve
007	2HR23M-A007	Molla	Spring
008	2HR23M-A008	Rondella	Washer
009	2HR23M-A009	Sede finale	End seat
010	2HR23M-A010	Sede centrale	Center seat
011	2HR23M-A011	Grilletto	Trigger
012	2HR23M-A012	Protezione grilletto	Trigger guard
013	2HR23M-A013	Boccola	Bushing
014	2HR23M-A014	Blocco-punti	Latch
015	2HR23M-A015	Piastra laterale	Side Plate
016	2HR23M-B016	Molla blocco punti	Spring Latch
017	2HR23M-A017	Rondella	Washer
018	2HR23M-A018	Pulsante	Trigger stem
019	2HR23M-A019	Valvola anteriore	Front Valve
020	2HR23M-A020	Distanziale	Spacer
021	2HR23M-A021	Ganascia inferiore	Jaw, Lower
022	2HR23M-A022	Ganascia superiore	Jaw, Upper
023	2HR23M-A023	Battente	Blade
024	2HR23M-A024	Perno	Pin
025	2HR23M-A025	Bussola	Roller
026	2HR23M-A026	Pistone	Piston Rod
027	2HR23M-A027	Nasello	Magazine shoe
029	2HR20M-A029	Molla	Spring
030	2HR23M-A030	Protezione	Guard
031	2HR23M-A031	Bussola	Roller
032	2HR23M-A032	Molla	Spring
033	2HR23M-A033	Supporto	Bracket
034	2HR23M-A034	Spingipunto	Pusher
035	2HR23M-A035	Caricatore	Magazine
036	2HR23M-A036	Molla	Clip
037	2HR23M-A037	Supporto caricatore	Rail Unit
038	2HR23M-A038	Rondella	Washer
039	2HR23M-B039	Grip	Grip
040	2HR23M-A040	Ammortizzatore	Bumper
041	2HR23M-B041	Gommino	Plastic Pin
042	2HR23M-B042	Silenziatore	Silencer
501	2HR23M-A501	Vite	Screw
502	2HR23M-A502	O-Ring	O-Ring
504	2HR23M-A504	O-Ring	O-Ring
505	2HR23M-A505	Vite	Screw
506	2HR23M-A506	O-Ring	O-Ring
507	2HR23M-A507	Attacco rapido	Air Plug
508	2HR23M-A508	Anello elastico	C-Ring
509	2HR23M-A509	Silenziatore	Silencer
510	2HR23M-A510	Vite	Screw
512	2HR23M-B512	Vite	Screw
513	2HR23M-A513	Perno	Spring Pin
514	2HR23M-A514	Dado	Nut
515	2HR23M-A515	Dado	Nut
516	2HR23M-B516	Vite	Screw
517	2HR23M-A517	Perno	Spring Pin
518	2HR23M-A518	Vite	Screw
519	2HR23M-A519	Perno	Spring Pin
520	2HR23M-A520	Vite	Screw
521	2HR23M-A521	Vite	Screw
521	2HR23M-A521	Vite	Screw
522	2HR23M-B522	Vite	Screw
523	2HR23M-A523	Vite	Screw
524	2HR23M-A524	Dado	Nut
525	2HR23M-A525	O-Ring	O-Ring
526	2HR20M-A526	Perno	Spring Pin
527	2HR23M-B527	Perno	Spring Pin

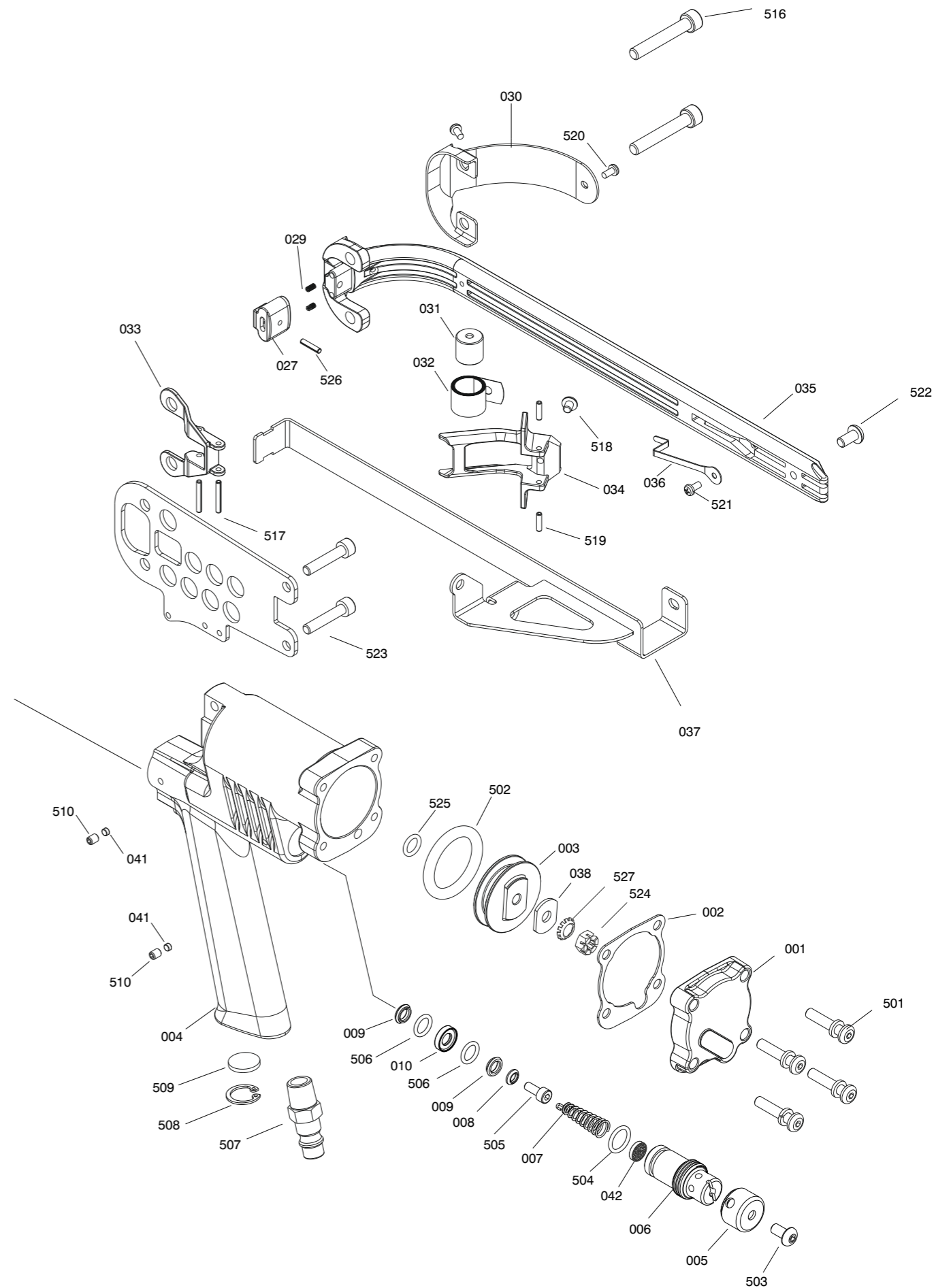
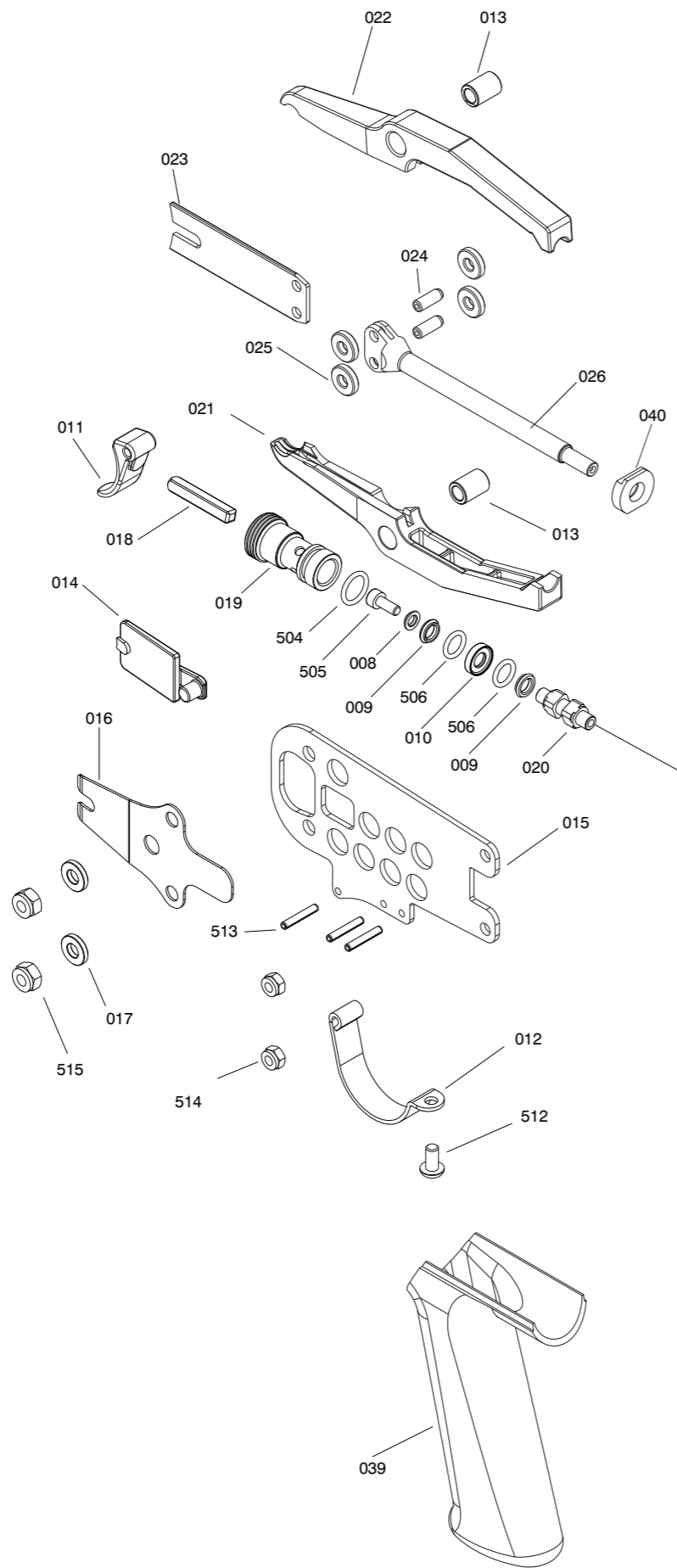

192HR23MA2_HR23M8_291013 IV

Parti di ricambio - Spare parts

HR23 M8

Cod. 192HR23MA2

Indice di modifica
Upgrade number

A2

213847