

Dati tecnici

Lubrificazione consigliata:

Olio per utensili pneumatici

Applicazioni:

Recinzioni, scatole per l'imballaggio, foderatura, pannelli, pavimentazioni, rivestimenti, fissaggio tavole in legno e altre costruzioni in legno.

Sistema di funzionamento:

Grilletto-Duo (sparo sequenziale singolo / azionamento a contatto)

Caricamento

1. Sbloccare la chiusura per aprire porta e caricatore.
2. Caricare i chiodi nel caricatore dentro il sistema di alimentazione.
3. Chiudere il caricatore e assicurarsi che il chiavistello sia chiuso correttamente.

Technical data

Recommended lubrications:

Pneumatic tool oil

Applications & suitability:

Fencing, packing case, sheathing, panel, floor working, cladding, boarding and other wooden assemblies.

Actuating system:

Combi-Trigger (single sequential actuation / contact actuation)

Filling the magazine

1. Release latch to open the door and magazine.
2. Load nails onto pivot in the magazine and full forward so that the nails are inserted into the feeder mechanism.
3. On closing the magazine ensure the latch is closed properly.

195MCN2132D1_CN2132D1_281019 IV

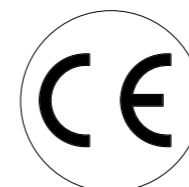

Manuale d'uso, manutenzione e parti di ricambio Parte 2

Use, maintenance and spare parts manual Part.2

CN21.32 D1

cod. 195MCN2132D1

Indice di modifica
Upgrade number

A1

Misure impiegabili mm (inch) Usable lengths mm (inch)	16 ÷ 32 (5/8" ÷ 1-1/4")
---	--

Capacità caricatore n° punti Magazine capacity No. of fasteners	150
---	------------

Pressione d'esercizio bar (psi) Working pressure bar (psi)	5 ÷ 7 (70 ÷ 100)
--	-----------------------------------

Consumo aria litri/colpo a 7 bar Air consumption litres/shot at 7 bar	0,73
---	-------------

Peso kg Weight kg	1,33
-----------------------------	-------------

Dimensioni (AxBxH) mm Dimensions mm	274x100x238
---	--------------------

Pressione sonora Max A-Weighted surface impulse sound pressure level	79,1 dBA
--	-----------------

Potenza sonora emessa Max A-Weighted impulse sound power level	92,1 dBA
--	-----------------

Vibrazione Vibration	< 2,5 m/s²
--------------------------------	---------------------------------

Tipo di punto
Type of fastener

CNP 21

Ø 5,5
Head dia: .216"

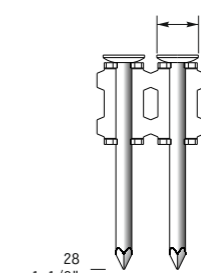

Ø 2,03
Shank dia: .080"
Gauge: 14

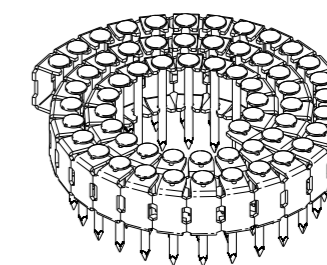

Dotazioni - Equipment

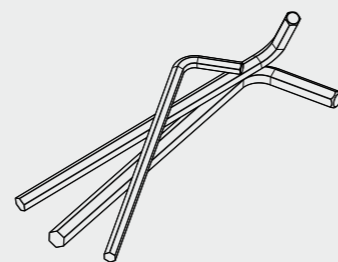
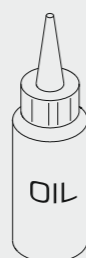
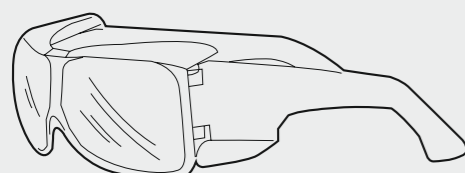

omer s.p.a.

Via Foresto, 42 - 31058 SUSEGANA (TV) ITALY
Tel. 0438 455 318 Fax 0438 455 530
e-mail: omer@omer.it www.omer.it

Ref. No. Part No. Description

101	2MCN2132-A101	Bolt assy
102	2MCN2132-A102	Cap
103	2MCN2132-A103	Hex. Soc. Hd. Screw
104	2MCN2132-A104	Collar
105	2MCN2132-A105	O-Ring
106	2MCN2132-A106	Hd. Valve Piston
107	2MCN2132-A107	O-Ring
108	2MCN2132-A108	Compression Spring
109	2MCN2132-A109	Cylinder Cap Seal
110	2MCN2132-A110	O-Ring
111	2MCN2132A511	Driver unit
112	2MCN2132-A112	O-Ring
113	2MCN2132-A113	Cylinder spacer
114	2MCN2132-A114	O-Ring
115	2MCN2132-A115	Cylinder
116	2MCN2132-A116	Cylinder ring
117	2MCN2132-A117	Bumper
201	2MCN2132-A201	Spring
202	2MCN3165-A209	O-Ring
202A	2MCN2132-A202A	O-Ring
203	2MCN2132-A203	Plunger
204	2MCN2132-A204	Cap
205	2MCN2132-A205	O-Ring
206	2MCN2132-A206	Spring
207	2MCN2132-A207	Trigger Unit
208	2MCN2132-A208	Spring pin
209	2MCN2132-A209	Spring pin
210	2MA34100-A442	Spring pin
301	2MCN2132-A301	Gun Body Unit
302	2MCN2132-A302	O-Ring
303	2MCN2132-A303	Link rod
304	2MCN2132-A304	Gasket
306	2MCN2132-A306	Gasket
307	2MCN2132-A307	Spring retainer
308	2MCN2132-A308	Rubber pad
309	2MCN2132-A309	End cap
310	2MCN3165-A107	Hex. Soc. Hd. Bolt
311	2MCN2132-A311	Muffler
312	2MCN2132-A312	Guide plate
313	2MCN3165-A304	Dusty cover
314	2MCN3165-A305	Air plug
401	2MCN2132-A401	O-Ring
403	2MCN3390-A402	O-Ring
404	2MCN3165-A206	O-Ring
405	2MCN2132-A405	Feed piston
406	2MCN2132-A406	O-Ring
407	2MCN2132-A407	Feed piston spring
408	2MCN2132-A408	Feed Bumper
409	2MCN2132-A409	Feed piston cap
410	2MCN2132-A410	C-ring
411	2MCN2132-A411	Feed finger
412	2MCN2132-A412	Spring pin
413	2MCN2132-A413	Door
414	2MCN2132-A414	Latch spring
415	2MCN2132-A415	Door latch
416	2MCN2132-A416	Spiral pins
417	2MCN2132-A417	Door shaft pin
418	2MCN2132-A418	Magazine case
419	2MCN2132-A419	Magazine cover
420	2MCN2132-A420	Pin
421	2MCN2132-A421	Hex. Soc. Hd. Bolt
422	2MCN2132-A422	Flat washer
423	2MCN2132-A423	Bolt cap
425	2MCN2132-A425	Adjust axie
427	2MCN2132-A427	Safety
428	2MCN2132-A428	Safety Spring
429	2MCN2132-A429	Safety guide
430	2MCN2132-A430	O-Ring
432	2MCN2132-A432	Bolt Assy
435	2MCN2132-A435	O-Ring
500	2MCN2132A500	Nose piece
501	2MCN2132A501	Spacer
502	2MCN2132A502	Jaw
503	2MCN2132A503	Safety Plate
504	2MCN2132A504	Safety A unit
508	2MCN2132A508	Backing
510	13.66	Pin
512	09.14	Washer
513	04.25	Screw
514	06.05.4	Screw
515	39.13	Cushion
516	92.04	Spring

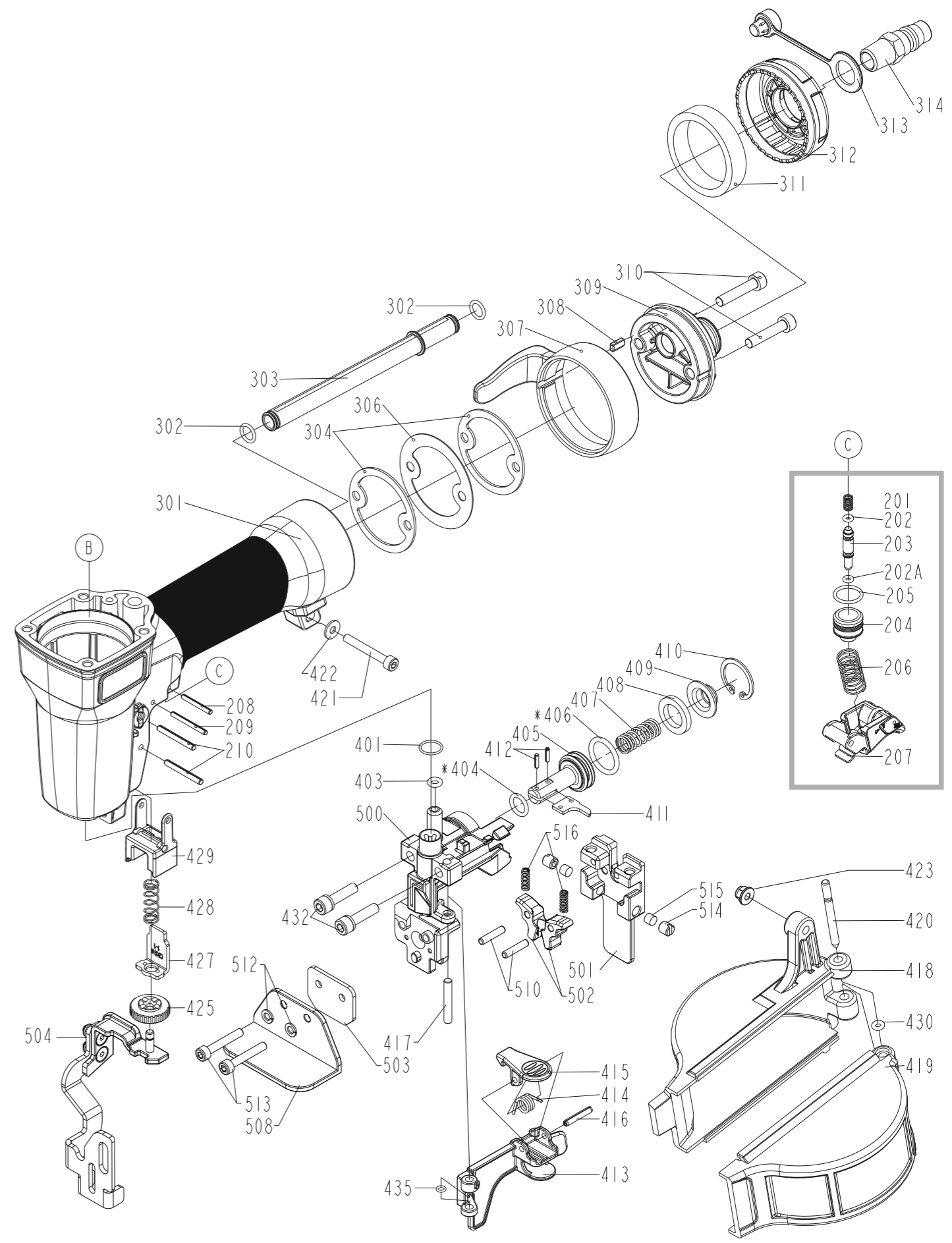
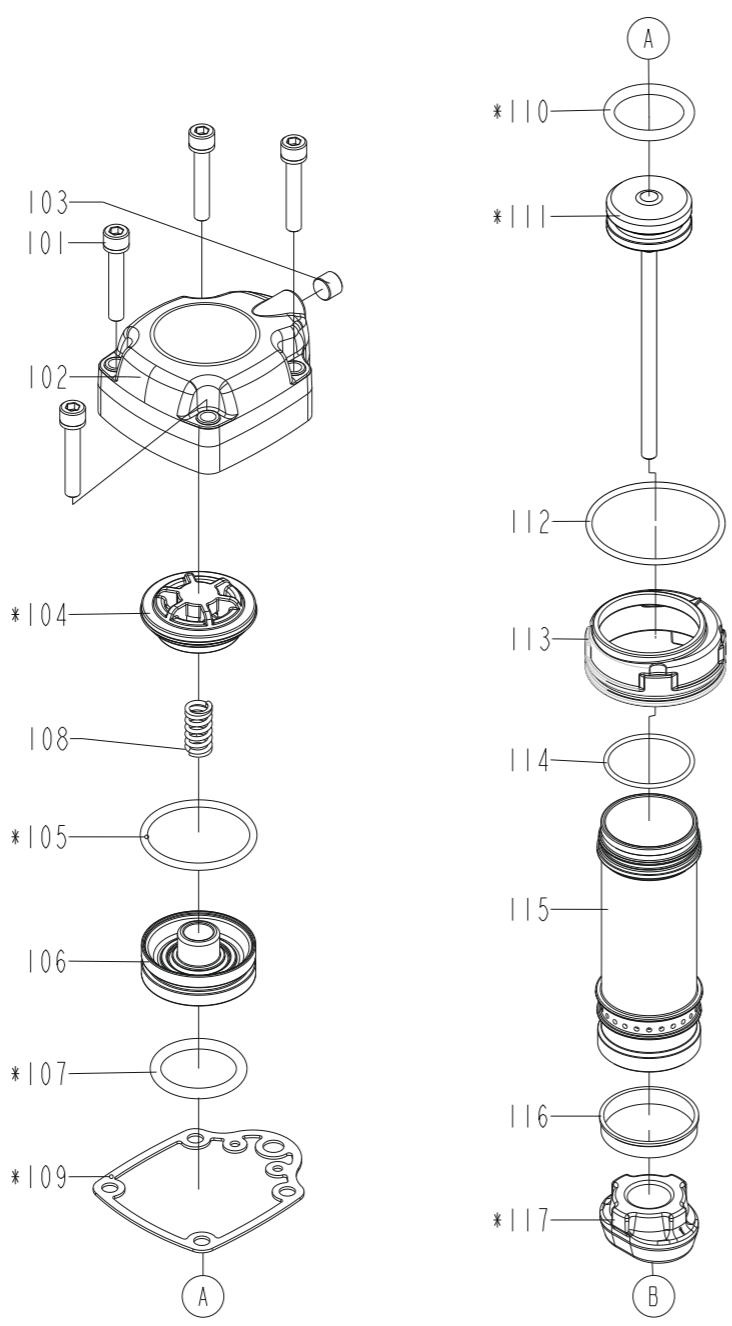

Parti di ricambio - Spare parts

CN21.32 D1

cod. 195MCN2132D1

Indice di modifica
Upgrade number

A1

17120096

195MCN2132D1_CN2132D1_281019 IV