

Dati tecnici

Lubrificazione consigliata:

Olio per utensili pneumatici

Applicazioni:

Carpenteria pesante, sotto pavimento, roofing, rivestimenti, pallets, scatole e gabbie.

Sistema di funzionamento:

Grilletto-Duo
(sparo sequenziale singolo / azionamento a contatto)

Caricamento

1. Arretrare lo spingipunto fino alla posizione di scatto.
2. Inserire le graffe mettendole a cavallo del caricatore.
3. Premere il pulsante per rilasciare il meccanismo di chiusura seguendo lo spingipunto fino alla chiusura ricordando di tener le dita lontano dal percorso dello stesso.

Technical data

Recommended lubrications:

Pneumatic tool oil

Applications & suitability:

Heavy-duty framing, sub floors, roofing, sheathing, pallets, boxes and crates.

Actuating system:

Combi-Trigger
(single sequential actuation / contact actuation)

Filling the magazine

1. Pull back the pusher mechanism until it latches into position.
2. Load the staple onto the top ridge of the magazine.
3. Press the button latch to releases the latch mechanism to allow the pusher to close remembering to take care and keep fingers well clear of its pathway.

195MM365A1_M365_170216 IV

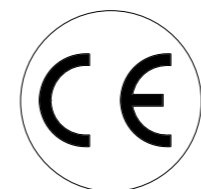

Manuale d'uso, manutenzione e parti di ricambio Parte 2

Use, maintenance and spare parts manual Part.2

M3.65

cod. 195MM365A1

Indice di modifica
Upgrade number

A1

Misure impiegabili mm (inch) Usable lengths mm (inch)	32 ÷ 65 (1-1/4" ÷ 2-5/8")
Capacità caricatore n° punti Magazine capacity No. of fasteners	160
Pressione d'esercizio bar (psi) Working pressure bar (psi)	5 ÷ 8 (70 ÷ 115)
Consumo aria litri/colpo a 7 bar Air consumption litres/shot at 7 bar	1,25
Peso kg Weight kg	2,50
Dimensioni (AxBxH) mm Dimensions mm	369x98x338
Pressione sonora Max A-Weighted surface impulse sound pressure level	96,6 dBA
Potenza sonora emessa Max A-Weighted impulse sound power level	83,6 dBA
Vibrazione Vibration	3,17 m/s²

Tipo di punto
Type of fastener

M3

1,60x1,90

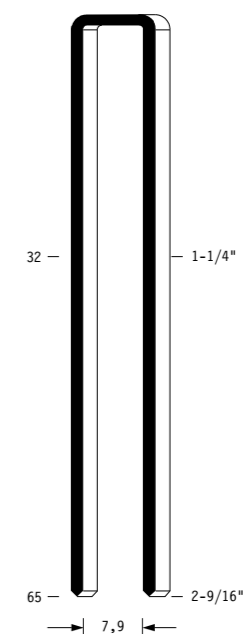

Gauge: 15

Crown: .437" (7/16")



Dotazioni - Equipment

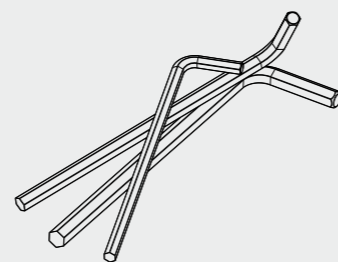
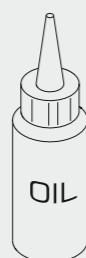
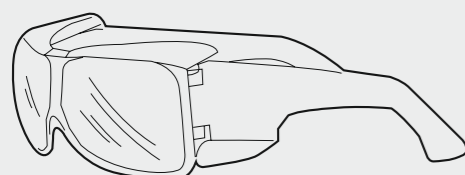

omer s.p.a.

Via Foresto, 42 - 31058 SUSEGANA (TV) ITALY
Tel. 0438 455 318 Fax 0438 455 530
e-mail: omer@omer.it www.omer.it

Ref. No. Part No. Description

101	2MM365-A101	Deflector Pad
102	2MM365-A102	Deflector
103	2MM365-A103	O-Ring
104	2MM365-A104	Bolt W/Flat Washer
105	2MCN2970-A104	Hex. Soc. Hd. Screw
107	2MM365-A107	Cap
108	2MCN2357-A111	Washer Seal
109	2MCN2357-A112	Seal
110	2MM365-A110	Compression Spring
111	2MCN2357-A116	Washer
112	2MCN2970-A109	O-Ring
113	2MM365-A113	Hd. Valve Piston
114	2MCN2357-A114	O-Ring
115	2MM365-A115	Packing
116	2MM365-A116	Press Ring
117	2MM365-A117	Cylinder Press Ring
118	2MM365-A118	O-Ring
119	2MM365-A119	Driver Unit
120	2MM365-A120	Collar
121	2MM365-A121	Cylinder
122	2MM365-A122	O-Ring
123	2MM365-A123	Cylinder Spacer
124	2MM365-A124	O-Ring
125	2MM365-A125	Cylinder Ring
126	2MCN3165-A124	Bumper
200	2MCN3165-A200	Trigger Valve Unit
201	2MCN3165-A201	O-Ring
202	2MCN3165-A202	O-Ring
203	2MCN3165-A203	Plunger Cap
204	2MCN3165-A204	Valve Plunger
205	2MCN3165-A205	O-Ring
206	2MCN3165-A206	O-Ring
207	2MCN3165-A207	Spring
208	2MCN2550-A208	Plunger
209	2MCN3165-A209	O-Ring
210	2MCN3165-A210	Trigger Valve Head
211	2MCN3165-A211	Spring Pin
212	2MCN3165-A212	Spring Pin
213	2MCN3165-A213	Spring Pin
214	2MCN2550-A215	Trigger Unit
215	2MCN2550-A214	Spring
301	2MM365-A301	Gun Body Unit
302	2MCN3165-A303	O-Ring
303	2MCN3165-A302	End Cap
304	2MCN3165-A304	Dusty Cover
305	2MCN3165-A305	Air Plug
401	2MM365-A401	Base
402	2MCN3165-A402	O-Ring
403	2MCN3165-A429	Hex. Soc. Hd. Bolt
404	2MCN3165-A458	O-Ring
405	2MM365-A405	Driver Guide
406	2MM365-A406	Driver Guide
407	2MM365-A407	Driver Guide Cover
408	2MM365-A408	Driver Guide Cover
409	2MM365-A409	Lock Handle Unit
410	2MM365-A410	Feed Finger Plug
411	2MCN3165-A414	Pu Retainer
412	2MM365-A412	Spiral Pins
413	2MCN3165-A432	Safety Guide
414	2MCN3165-A433	Spring Pin
415	2MCN3165-A434	Safety Spring
416	2MM365-A416	Safety B
417	2MCN3165-A436	Adjust Axie
418	2MCN3165-A437	Cover-Safety
419	2MCN3165-A438	Adjust Rod
420	2MCN3165-A439	O-Ring
421	2MM365-A421	Safety
422	2MCN3165-A441	E-Ring
423	2MM365-A423	Bolt Assy
424	2MM365-A424	Mounting Bracket
425	2MM365-A425	Pusher
426	2MM365-A426	Magazine A
427	2MM365-A427	Half Round Hd. Hex. Bolt
428	2MM365-A428	Spring
429	2MM365-A429	Special Screw
430	2MS29130-A439	Door Latch
431	2MS29130-A438	Latch Spring
432	2MS29130-A435	E-Ring
433	2MM365-A433	Positioning Sheet
434	2MCN3165-A428	Hex. Soc. Hd. Bolt
435	2MCN3165-A452	Flat Washer
436	2MCN3165-A431	Bolt Cap
437	2MM365-A437	Safety Spring
438	2MM365-A438	O-Ring
439	2MM365-A439	Hinge Point

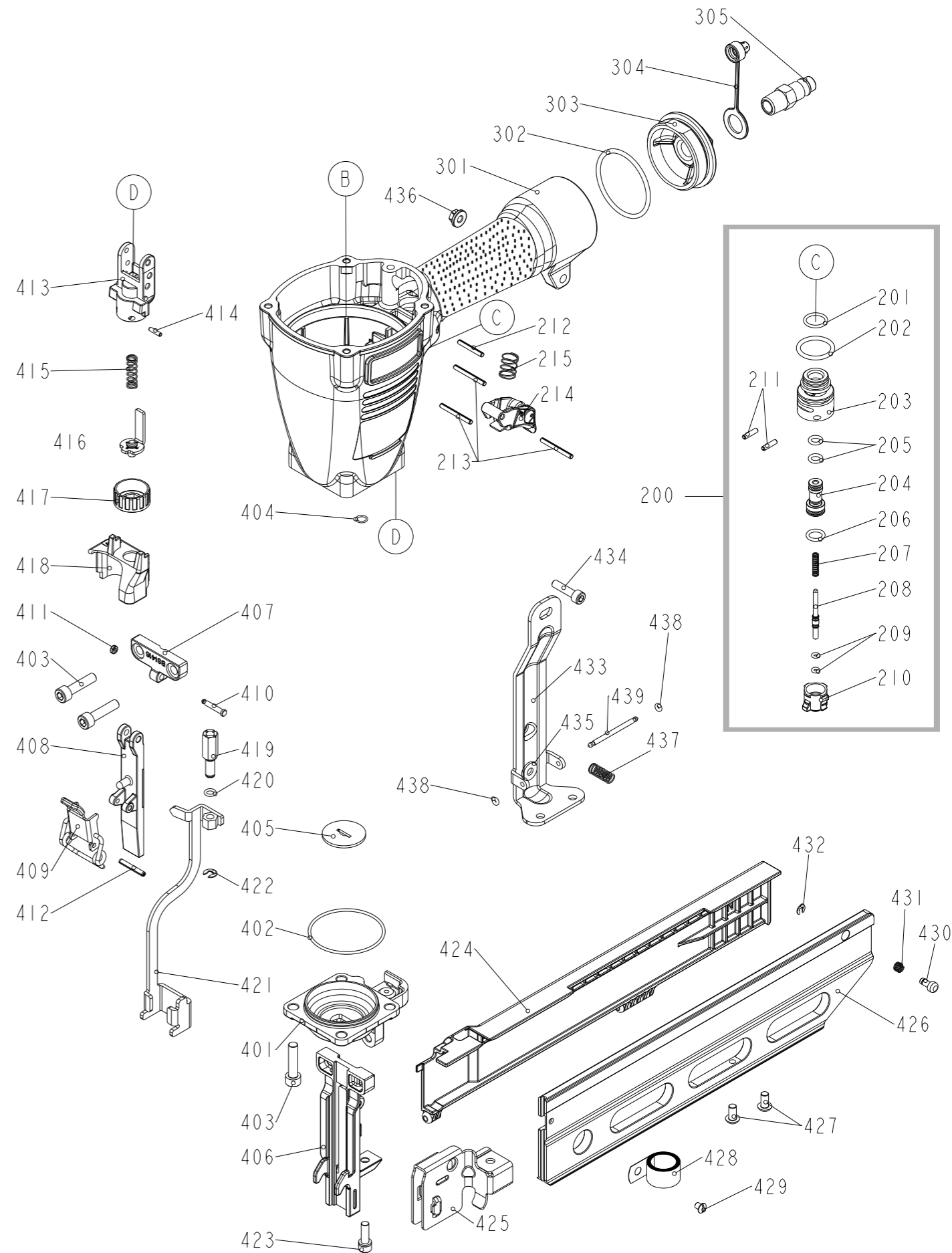
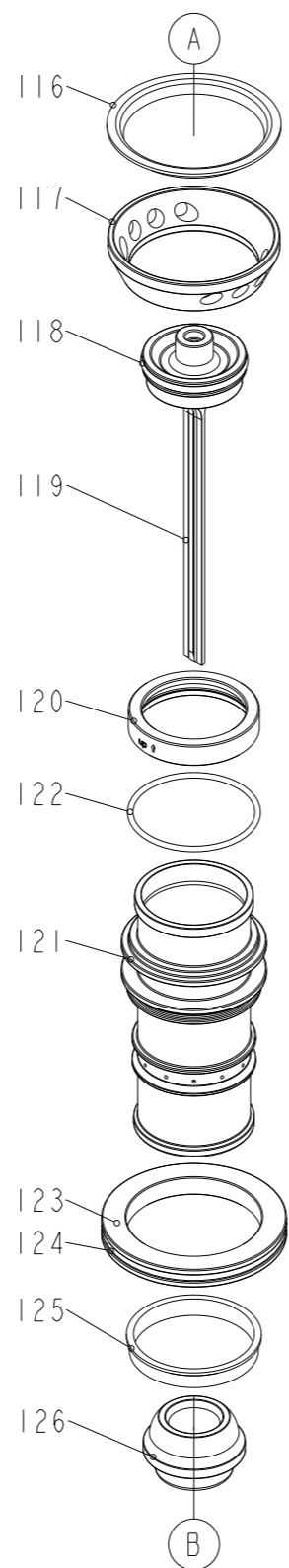
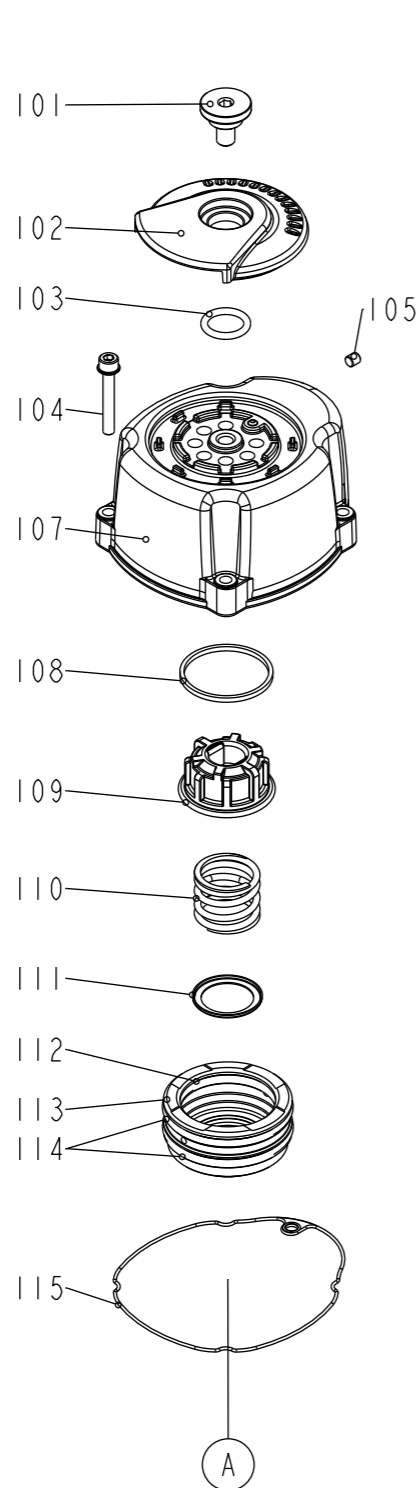

195MM365A1_M365_170216 IV

Parti di ricambio - Spare parts

M3.65

cod. 195MM365A1

Indice di modifica Upgrade number

A1

09233767