

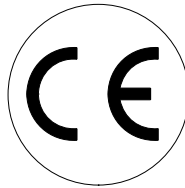

# PR.18-2722

cod. 10802800-2722

10802800-2722\_PR18\_8 071019 IV



<b>Dati tecnici</b> Technical data Technische daten	<b>Données techniques</b> Datos tècnicos Τεχνικά χαρακτηριστικά	<b>Dados tècnicos</b> Technische gegevens Tehniske data	
<b>Misure impiegabili mm</b> Usable lengths mm Gebrauchliche Längen mm	Mesures utilisable mm Medidas que se pueden emplear mm Διαστάσεις σε μμ	Medidas que se podem utilizar mm Te gebruiken engtes in mm Brugbare længder i mm	<b>10 ÷ 18</b>
<b>Capacità caricatore n° punti</b> Magazine capacity No. of fasteners Magazinkapazität Nägel	Capacité chargeur n° de points Capacidad cargador n° puntos Δυνατότητα γεμιστερα, σπνδτερες	Capacidade carregador n° pontos Capaciteit magazijn in aantal spijkers Kapacitet af magasin antal klemme	<b>200</b>
<b>Pressione d'esercizio</b> Working pressure Betriebsdruck	Pression de fonctionnement Presión de trabajo Πιεση λειτουργιασ ατμ.	Pressao de trabalho Werkdruk Arbejds tryk bar	<b>4 ÷ 7 bar 60 ÷ 100 psi</b>
<b>Consumo aria litri/colpo</b> Air consumption litres/shot Luftverbrauch Liter/Schlag	Consommation air litre/coup Consumo aire-litros/golpe Καταναλοση αερα λ/ξτπημα	Consumo ar litro/golpe Luchtverbruik liter/schot Luftforbrug liter/skud	<b>0,1</b>
<b>Peso kg</b> Weight kg Gewicht kg	Poids kg Peso kg Βαροσ κγ	Peso kg Gewicht in kg Vaegt kg	<b>0,70</b>
<b>Dimensioni (AxBxH) mm</b> Dimensions mm Größe mm	Dimension mm Dimensiones mm Δυνατότητα γεμιστερα , σπνδτερες	Dimencoes mm Afmetingen in mm Dimensioner mm	<b>200x33x148</b>
<b>EN 12549 :1999 ISO 11201 :1995</b>			
<b>Pressione sonora in pos. operatore</b> Sound pressure at the workstation Lärmintensität am Arbeitsplatz	Pression acoustique près de l'opérateur Presión sonora en posición encargado Ακουστικη πιεση στη θεση χειριστου	Intensidade sonora perto do operador Geluidssterkte op de werkplek Lydstyrke på operatorposten	<b>76,7 dB(A)</b>
<b>EN 12549 :1999 ISO 3744 :1994</b>			
<b>Potenza sonora emessa</b> Emitted sound power Ausgestrahlte Lärmintensität	Puissance acoustique émise Potencia sonora emitida Ακουστικη ισχυ	Potência sonora emitida Uitgestraalde geluidssterkte Udsendt lydstryrke	<b>82,2 dB(A)</b>
<b>ISO 5349 :1986</b>			
<b>Valore medio ponderato di vibrazione sull'impugnatura</b> Weighted mean value of vibration on the grip Mittlerer Vibrationswert, am Griff Gemessen	Valeur moyenne pondérée de vibration mesurée sur la poignée Valor medio ponderado de vibracion medida en la empuñadura Μεσοσ ορος μετρησισ κραδασιμον στη χειρολαβη	Valor medio ponderado de vibracao medida no punho Gewogen gemiddelde vibratiewaarde Middelvaerdi af vibrationer pa handtaget	<b>&lt;2,5 m/s²</b>

**Tipo di punto**  
Type of fastener  
Befestigungselement  
Type d'agrafe  
Tipo de punto  
Τυπος καρφιου  
Tipo de ponto  
Type nietjes  
Tilspændingstype

**Pins 6**

Ø 0,64

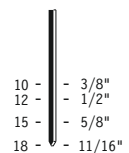

Wire dia: 0.025"  
Gauge: 23

Parti di ricambio - Spare parts - Ersatzteile - Pièces de rechange - Piezas de repuesto  
 Ανταλλακτικά - Partes sobresselentes - Tabel te raadplegen - Reservedele

Cod.	Descrizione	Description
00.04	O-Ring	O-Ring
00.06	O-Ring	O-Ring
00.10.2	O-Ring	O-Ring
00.22	O-Ring	O-Ring
00.26	O-Ring	O-Ring
00.48	O-Ring	O-Ring
01.09	O-Ring	O-Ring
01.13.1	Guarnizione	Gasket
01.19	O-Ring	O-Ring
03.00	Dado	Nut
03.20	Vite	Screw
04.07	Vite	Screw
04.10	Vite	Screw
04.16	Vite	Screw
04.25	Vite	Screw
07.03	Sfera	Ball
07.25	Chiave esagonale	Hex. Bar wrench
07.30	Chiave esagonale	Hex. Bar wrench
09.02	Anello elastico	Elastic ring
09.03	Anello elastico	Elastic ring
12.58	Spina	Pin
22.11	Testa	Head
25.10	Deflettore	Exhaust deflector
26.10	Cilindro	Cylinder
32.03	Ammortizzatore	Bumper
41.12	Pistone valvola	Valve
44.01.1	Ammortizzatore	Bumper
45.12	Anello valvola	Ring
54.11	Pulsante	Trigger valve
59.10	Regolatore	Adjusting
60.10	Guida Sx	Sx guide
61.10	Guida Dx	Dx guide
72.10	Fermo carrello	Slider stop
76.10	Perno	Pin
76.11	Perno	Pin
76.43	Perno	Pin
80.05	Grilletto chiusura	Trigger
81.11	Grilletto comando	Trigger
81.12	Controgrilletto	Safety
81.34	Leva regolazione	Adjusting lever
86.42	Vite deflettore	Deflector screw
90.05	Molla	Spring
90.07	Molla	Spring
90.08	Molla	Spring
91.01X	Molla	Spring
93.02	Molla	Spring
94.10	Tirante	Connecting rod
10.10.05	Corpo	Body
20.10.05	Battente	Driver
30.10.05	Rondella	Washer
60.10.05	Carrello	Slider
70.10.05	Spingipunto	Pusher
80.10.05-2722	Controtestina	Nose
90.10.05	Testina	Nose plate

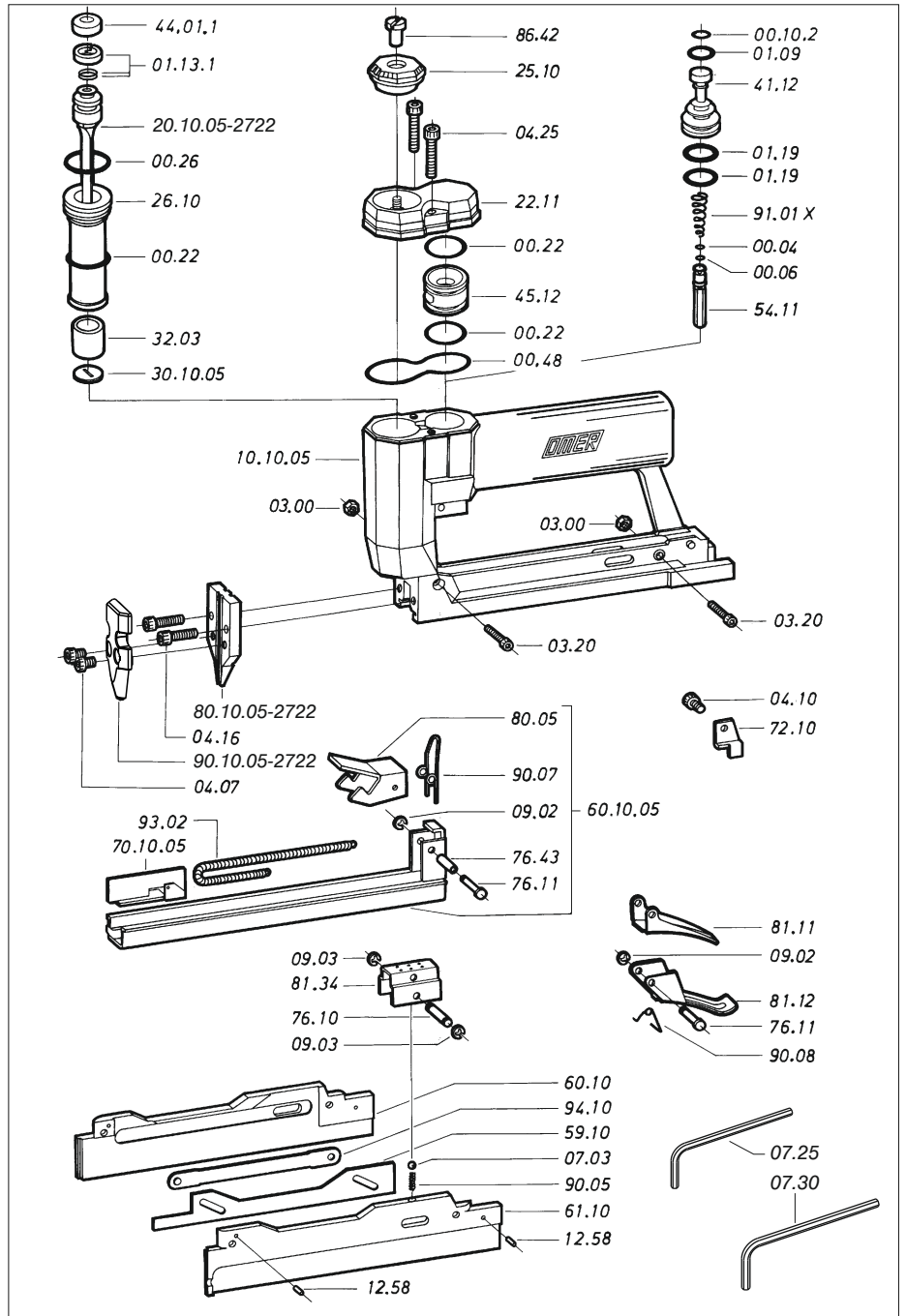

Guarnizioni - O-Rings - Dichtungen - Joints - Kit O-Rings - Λαστιχάκια - Kit O-Rings - O-ringen - Pakninger

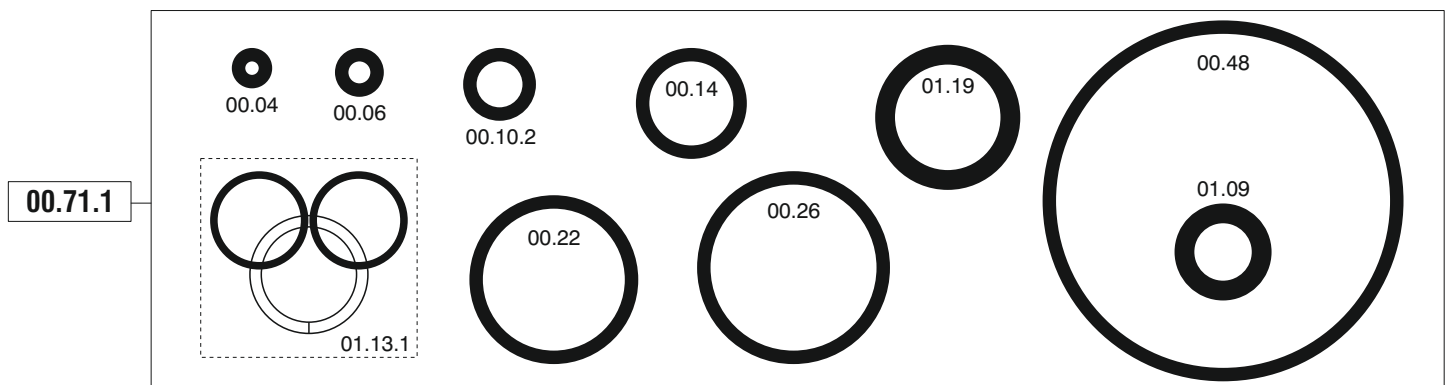

10802800-2722\_PR18\_8 071019 IV

PR.18-2722

cod. 10802800-2722

Indice di modifica  
Upgrade number

8

8306039