



Manuale d'uso, manutenzione e parti di ricambio **Parte 2**
Use, maintenance and spare parts manual **Part 2**
Gebrauchsanweisung, Instandhaltungsrichtlinien und Ersatzteile **Teil 2**
Manuel d'utilisation, entretien et pièces de rechange **Partie 2**
Manual de uso, mantenimiento y repuestos **Part 2**
 Εγχειρίδιο χρήσης, συντηρησης και ανταλλακτικών **2° Μέρος**
Manual de utilização, manutenção e partes sobresselentes **Parte 2**
Handleiding voor gebruik, onderhoud en reservedelslste **Deel 2**
Brugsanvisning, vedligeholdelse og reservedelslste **Del 2**

53.5 V

cod. 10880580

10880580_535V 080217 IV

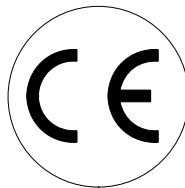

Dati tecnici Technical data Technische daten	Données techniques Datos tècnicos Τεχνικά χαρακτηριστικά	Dados tècnicos Technische gegevens Tecniske data
Misure impiegabili mm Usable lengths mm Gebrauchliche Längen mm	Mesures utilisable mm Medidas que se pueden emplear mm Διαστάσεις σε μμ	Medidas que se podem utilizar mm Te gebruiken engtes in mm Brugbare længder i mm
Capacità caricatore n° punti Magazine capacity No. of fasteners Magazinkapazität Nägel	Capacité chargeur n° de points Capacidad cargador n° puntos Δυνατότητα γεμιστέρα, σπινδέρες	Capacidade carregador n° pontos Capaciteit magazijn in aantal spijkers Kapacitet af magasin antal klemme
Pressione d'esercizio Working pressure Betriebsdruck	Pression de fonctionnement Presión de trabajo Πίεση λειτουργίας ατμ.	Pressao de trabalho Werkdruk Arbejds tryk bar
Consumo aria litri/colpo Air consumption litres/shot Luftverbrauch Liter/Schlag	Consommation air litre/coup Consumo aire-litros/golpe Κατανάλωση αερα λ/ξτπημα	Consumo ar litro/golpe Luchtverbruik liter/schot Luftforbrug liter/skud
Peso kg Weight kg Gewicht kg	Poids kg Peso kg Βαρος κγ	Peso kg Gewicht in kg Vaegt kg
Dimensioni (AxBxH) mm Dimensions mm Größe mm	Dimension mm Dimensiones mm Δυνατότητα γεμιστέρα , σπινδέρες	Dimencoes mm Afmetingen in mm Dimensioner mm
EN 12549 :1999 ISO 11201 :1995		
Pressione sonora in pos. operatore Sound pressure at the workstation Lärmintensität am Arbeitsplatz	Pression acoustique près de l'opérateur Presión sonora en posición encargado Ακουστική πίεση στη θέση χειριστού	Intensidade sonora perto do operador Geluidssterkte op de werkplek Lydstyrke på operatorposten
EN 12549 :1999 ISO 3744 :1994		
Potenza sonora emessa Emitted sound power Ausgestrahlte Lärmintensität	Puissance acoustique émise Potencia sonora emitida Ακουστική ισχυ	Potência sonora emitida Uitgestraalde geluidssterkte Udsendt lydstryrke
ISO 5349 :1986		
Valore medio ponderato di vibrazione sull'impugnatura Weighted mean value of vibration on the grip Mittler Vibrationswert, am Griff Gemessen	Valeur moyenne pondérée de vibration mesurée sur la poignée Valor medio ponderado de vibracion medida en la empuadura Μέσος ορος μετρησις κραδασιμον στη χειρολαβη	Valor medio ponderado de vibracao medida no punho Gewogen gemiddelde vibratiewaarde Middelvaerdi af vibrationer pa handtaget

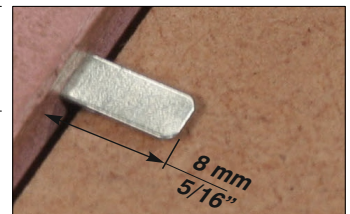

Tipo di punto
 Type of fastener
 Befestigungselement
 Type d'agrafe
 Tipo de punto
 Τυπος κάρφιου
 Tipo de ponto
 Type nietjes
 Tilspændingstype

53

Spessore 0.5

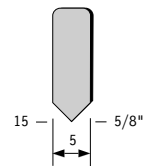

Width: .185" (3/16")
 Length: .59"
 Thickness: .0197"

Parti di ricambio - Spare parts - Ersatzteile - Pièces de rechange - Piezas de repuesto
 Ανταλλακτικά - Partes sobresselentes - Tabel te raadplegen - Reservedele

Cod.	Descrizione	Description
00.04	O-Ring	O-Ring
00.05	O-Ring	O-Ring
00.06	O-Ring	O-Ring
00.07	O-Ring	O-Ring
00.08	O-Ring	O-Ring
00.09	O-Ring	O-Ring
00.10.2	O-Ring	O-Ring
00.12	O-Ring	O-Ring
00.22	O-Ring	O-Ring
00.26	O-Ring	O-Ring
00.48	O-Ring	O-Ring
01.09	O-Ring	O-Ring
01.13.1	Guarnizione	Gasket
01.19	O-Ring	O-Ring
04.10	Vite	Screw
04.14	Vite	Screw
04.16	Vite	Screw
04.25	Vite	Screw
07.30	Chiave esagonale	Hex. Bar wrench
09.02	Anello elastico	Elastic ring
10.04	O-Ring	O-Ring
10.09	O-Ring	O-Ring
10.12	O-Ring	O-Ring
12.10.1	Spina	Pin
22.11	Testa	Head
25.10	Deflettore	Exhaust deflector
26.10.1	Cilindro	Cylinder
32.03	Ammortizzatore	Bumper
39.11	Guarnizione servov.	Valve gasket
39.12	Ammortizzatore	Bumper
41.12.1	Pistone valvola	Valve
44.01.1	Ammortizzatore	Bumper
45.12	Anello valvola	Ring
50.11	Dispositivo completo	Assembled device
51.12	Cilindro servovalvola	Servo valve cylinder
52.10	Tappo	Inlet cap
52.11	Boccola	Bushing
53.12	Pistone servovalvola	Valve piston
54.12	Pulsante	Trigger valve
55.11	Corpo servovalvola	Valve body
57.10	Regolatore	Regulator
57.11	Interruttore	Switch
72.11	Fermo carrello	Slider stop
76.11	Perno	Pin
76.15	Perno	Pin
76.43	Perno	Pin
80.05	Grilletto chiusura	Trigger
81.13	Grilletto comando	Trigger
86.42	Vite deflettore	Deflector screw
90.07	Molla	Spring
91.01X	Molla	Spring
91.04	Molla	Spring
91.71	Molla	Spring
10.18.03	Corpo	Body
22.10.03	Battente	Driver
32.10.03	Rondella	Washer
60.18.03	Carrello	Slider
72.10.03	Spingipunto	Pusher
92.15.03	Testina	Nose plate

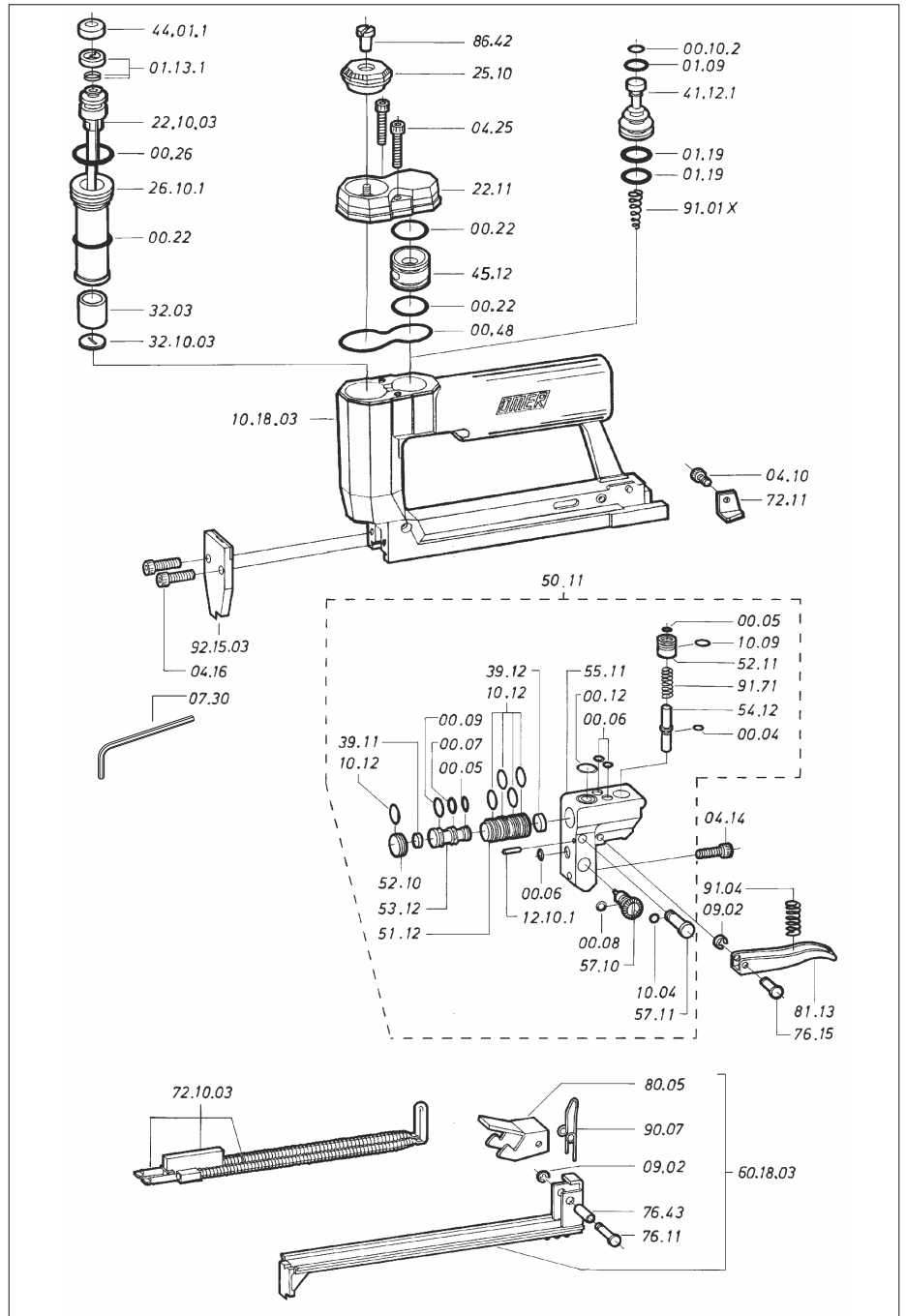

Guarnizioni - O-Rings - Dichtungen - Joints - Kit O-Rings - Λαστιχάκια - Kit O-Rings - O-ringen - Pakninger

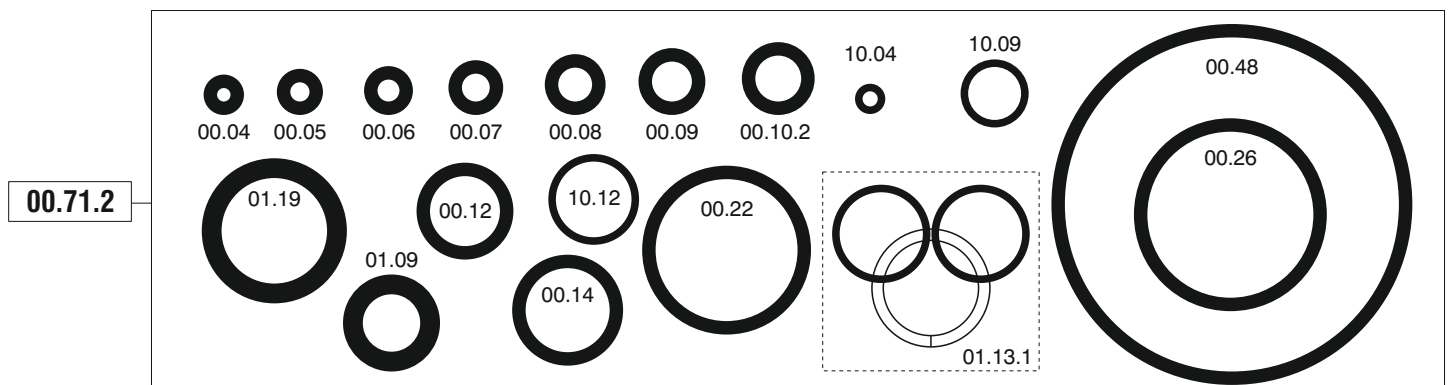

53.5 V

cod. 10880580

Indice di modifica
Upgrade number

8