



Manuale d'uso, manutenzione e parti di ricambio	Parte 2
Use, maintenance and spare parts manual	Part 2
Gebrauchsanweisung, Instandhaltungsrichtlinien und Ersatzteile	Teil 2
Manuel d'utilisation, entretien et pièces de rechange	Partie 2
Manual de uso, mantenimiento y repuestos	Part 2
Manual de utilização, manutenção e partes sobresselentes	Parte 2
Handleiding voor gebruik, onderhoud en reservedeelslste	Deel 2
Brugsanvisning, vedligeholdelse og reservedeelslste	Del 2

53.4 BAN-TAM

cod. 10880600-607

10880600-607_534BanTam_8 100510 IV

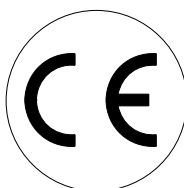

Dati tecnici Technical data Technische daten	Données techniques Datos tècnicos	Dados tècnicos Technischegegevens Tecniske data
Misure impiegabili mm Usable lengths mm Gebrauchliche Längen mm	Mesures utilisable mm Medidas que se pueden emplear mm	Medidas que se podem utilizar mm Te gebruiken engtes in mm Brugbare laengder i mm
Capacità caricatore n° punti Magazine capacity No. of fasteners Magazinkapazität Nägel	Capacité chargeur n° de points Capacidad cargador n° puntos	Capacidade carregador n° pontos Capaciteit magazijn in aantal spijkers Kapacitet af magasin antal klemme
Pressione d'esercizio Working pressure Betriebsdruck	Pression de fonctionnement Presión de trabajo	Pressao de trabalho Werkdruk Arbejds tryk bar
Consumo aria litri/colpo Air consumption litres/shot Luftverbrauch Liter/Schlag	Consommation air litre/coup Consumo aire-litros/golpe	Consumo ar litro/golpe Luchtverbruik liter/schot Luftforbrug liter/skud
Peso kg Weight kg Gewicht kg	Poids kg Peso kg	Peso kg Gewicht in kg Vaegt kg
Dimensioni (AxH) mm Dimensions mm Größe mm	Dimension mm Dimensiones mm	Dimencoes mm Afmetingen in mm Dimensioner mm
EN 12549 :1999 ISO 11201 :1995		
Pressione sonora in pos. operatore Sound pressure at the workstation Lärmintensität am Arbeitsplatz	Pression acoustique près de l'opérateur Presión sonora en posición encargado	Intensidade sonora perto do operador Geluidssterkte op de werkplek Lydstyrke på operatorposten
EN 12549 :1999 ISO 3744 :1994		
Potenza sonora emessa Emitted sound power Ausgestrahlte Lärmintensität	Puissance acoustique émise Potencia sonora emitida	Potência sonora emitida Uitgestraalde geluidssterkte Udsendt lydstryrke
ISO 5349 :1986		
Valore medio ponderato di vibrazione sull'impugnatura Weighted mean value of vibration on the grip Mittlerer Vibrationswert, am Griff Gemessen	Valeur moyenne pondérée de vibration mesurée sur la poignée Valor medio ponderado de vibracion medida en la empuñadura	Valor medio ponderado de vibracao medida no punho Gewogen gemiddelde vibratiewaarde Middelvaerdi af vibrationer pa handtaget

Tipo di punto
Type of fastener
Befestigungselement
Type d'agrafe
Tipo de punto

Tipo de ponto
Type nietjes
Tilspændingstype

Spessore 0.40

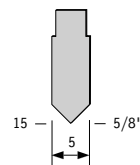

Width: 3/16"
Length: 0.59"
Thickness: 0.0157"

Parti di ricambio - Spare parts - Ersatzteile - Pièces de rechange - Piezas de repuesto
 - Partes sobresselentes - Tabel te raadplegen - Reservedele

Cod.	Descrizione	Description
00.04	O-Ring	O-Ring
00.06	O-Ring	O-Ring
00.10.2	O-Ring	O-Ring
00.22	O-Ring	O-Ring
00.26	O-Ring	O-Ring
00.48	O-Ring	O-Ring
01.09	O-Ring	O-Ring
01.13.1	Guarnizione	Gasket
01.19	O-Ring	O-Ring
04.04.4	Vite	Screw
04.10	Vite	Screw
04.16	Vite	Screw
04.25	Vite	Screw
07.20	Chiave esagonale	Hex. Bar wrench
07.30	Chiave esagonale	Hex. Bar wrench
09.02	Anello elastico	Elastic ring
17.31.5	Attacco	Coonection
18.00	Cilindro Pneumatico	Pneumatic Cylinder
18.10	Tubo	Pipe
22.11	Testa	Head
25.10	Deflettore	Exhaust deflector
26.11	Cilindro	Cylinder
32.03	Ammortizzatore	Bumper
41.12	Pistone valvola	Valve
44.01.1	Ammortizzatore	Bumper
45.12	Anello valvola	Ring
54.11	Pulsante	Trigger valve
72.11	Fermo carrello	Slider stop
73.10	Piegatore	Bender
76.11	Perno	Pin
76.14	Perno	Pin
76.43	Perno	Pin
80.05	Grilletto chiusura	Trigger
81.13.1	Grilletto comando	Trigger
86.42	Vite deflettore	Deflector screw
90.07	Molla	Spring
91.01X	Molla	Spring
91.04	Molla	Spring
10.16.03	Corpo	Body
20.16.03	Battente	Driver
32.10.03	Rondella	Washer
60.16.03	Carrello	Slider
72.17.03	Spingipunto	Pusher
80.17.03	Controtestina	Nose
90.16.03	Testina	Nose plate

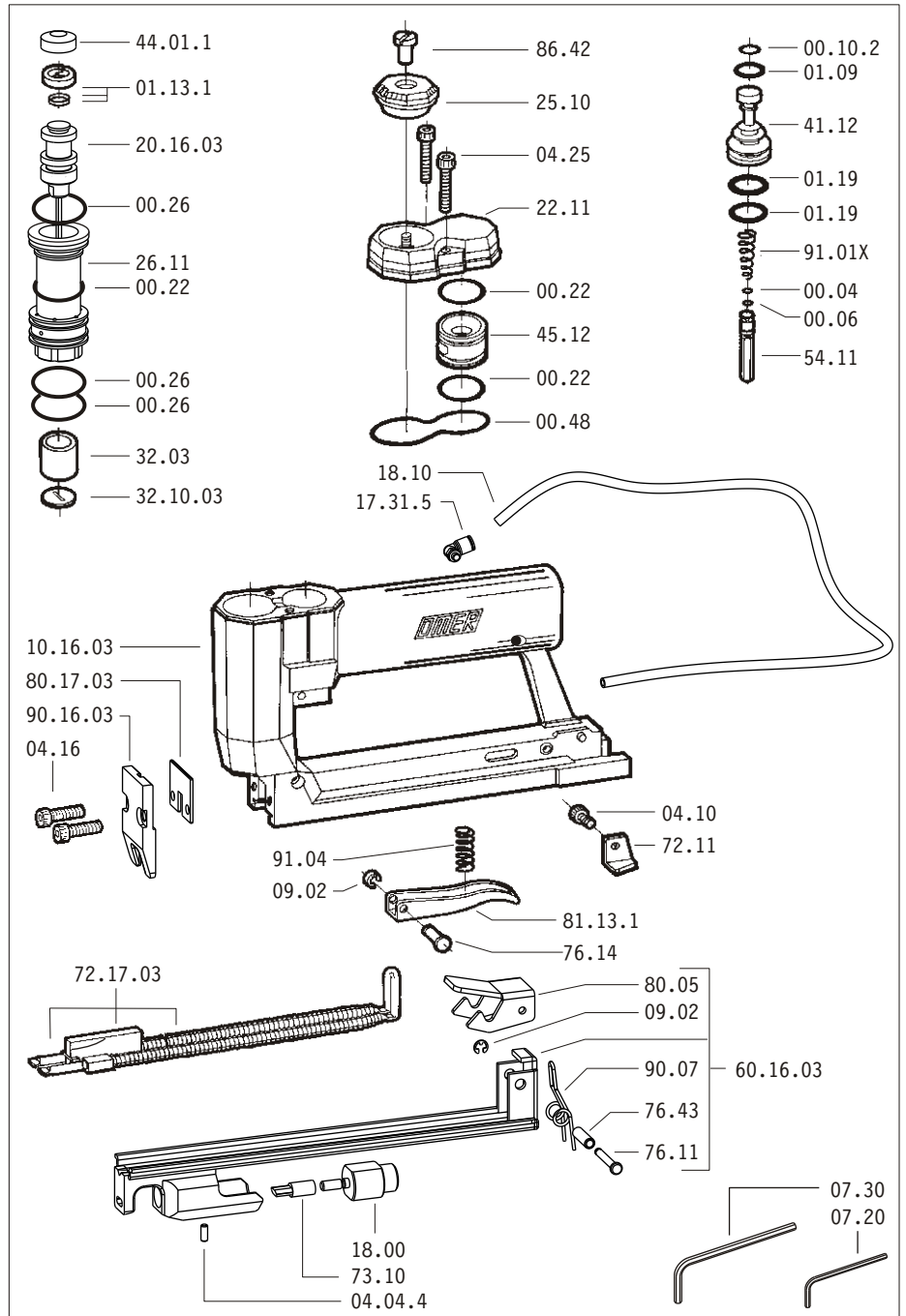

Guarnizioni - O-Rings - Dichtungen - Joints - Empaquetadura de anillo -

- Kit de o-rings - O-ringen - Pakninger

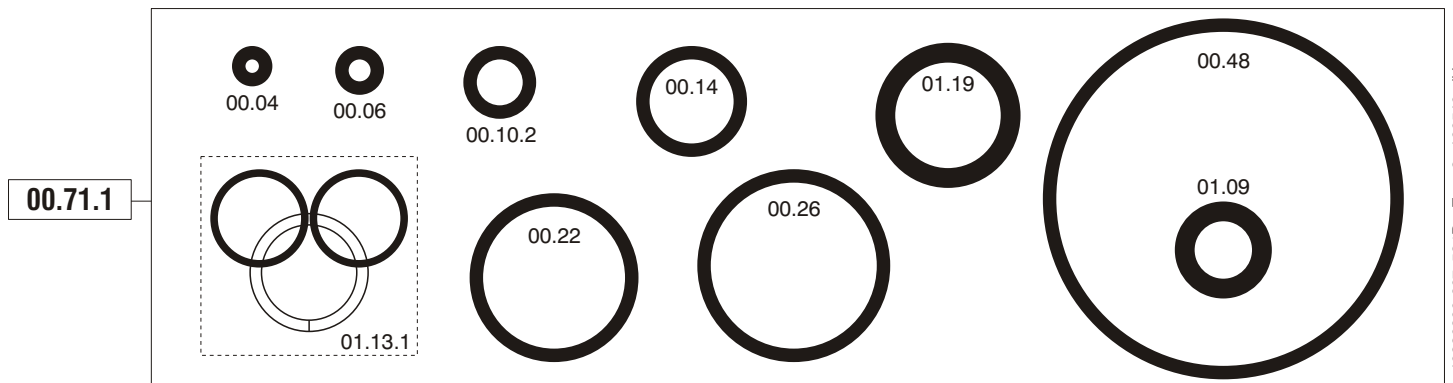

10880600-607_534BanTam_8 100510 IV

53.4 BAN-TAM cod. 10880600-607

Indice di modifica
 Upgrade number

8

8118676