

Azionamento singolo con doppia attivazione
Single actuation with dual activation

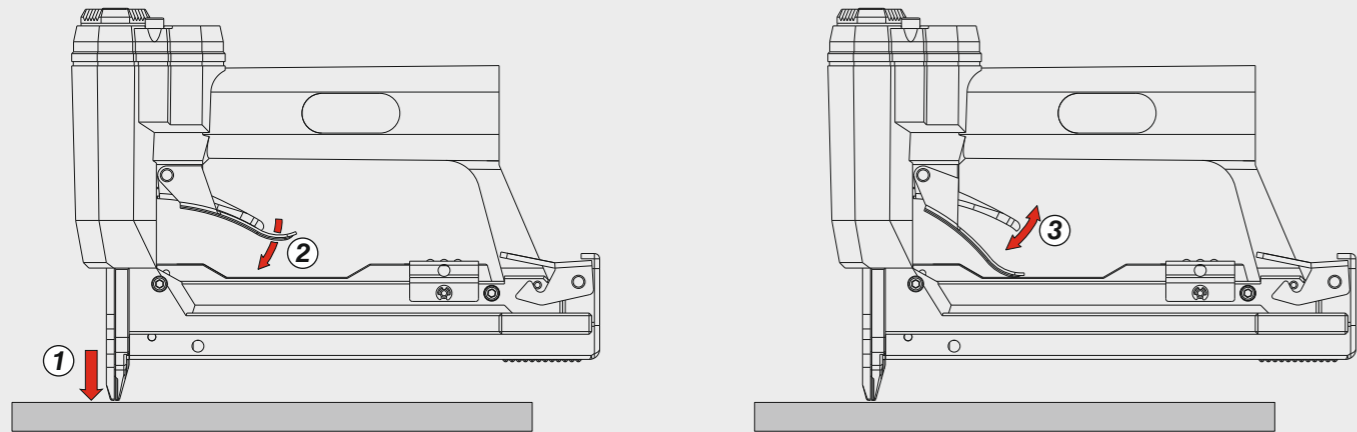

Caricamento - Loading - Laden - Chargement - Carga - Γέμισμα - Carregamento - Laden - Yükleme - Laddning - Laddar

Caricamento da sotto
Bottom load magazine

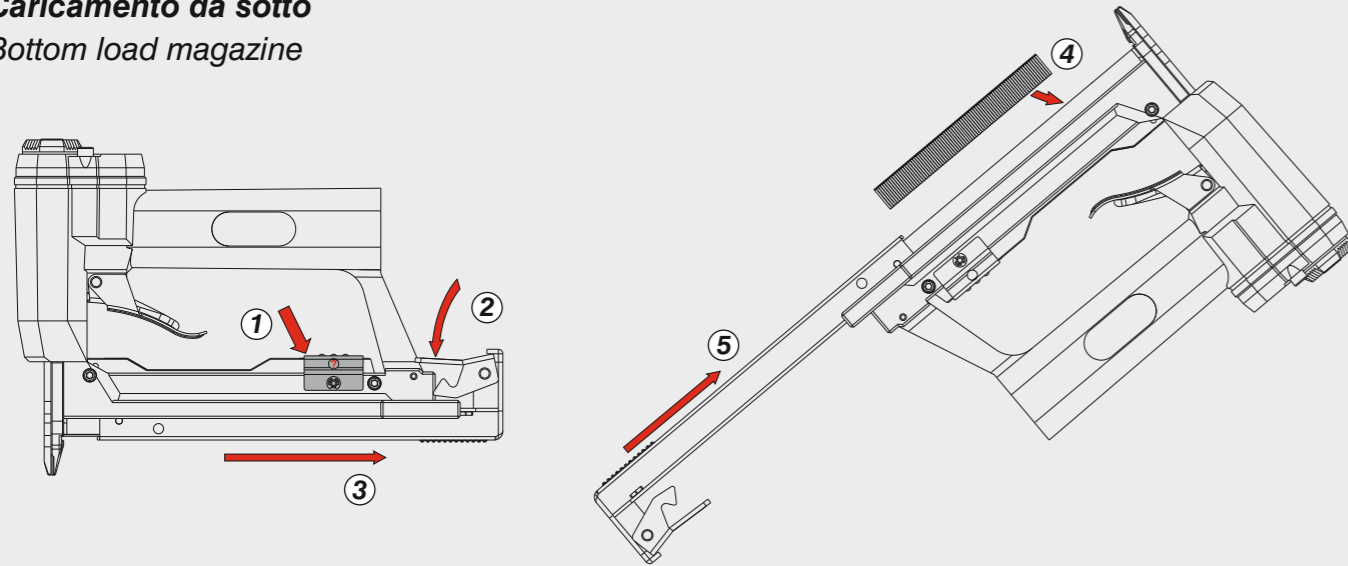

Regolazione misura - Length adjustment - Längeneinstellung - Réglage des dimensions
Regulación de la medida - Ρύθμιση μήκους - Regulação medida - Lengte-afstelling - Boy ayarı - Justering av mätning

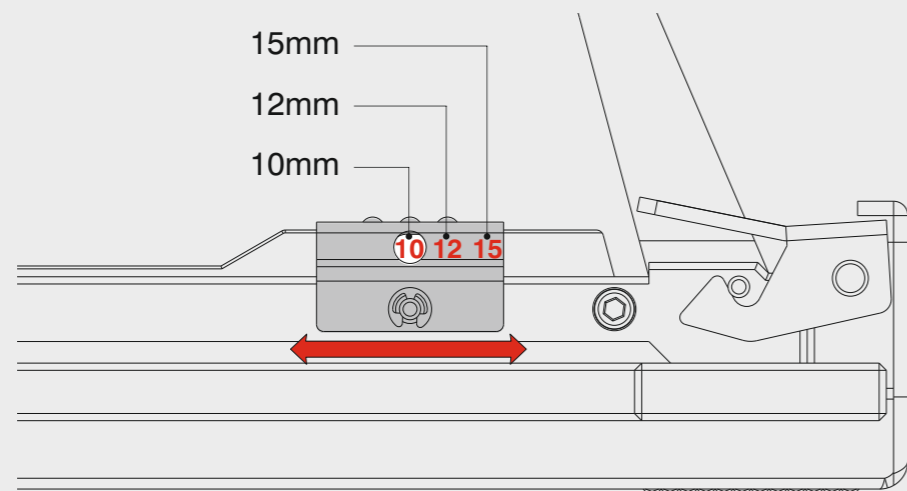

Manuale d'uso, manutenzione e parti di ricambio	Parte 2
Manual for use, maintenance and spare parts	Part 2
Bedienungs- und Wartungshandbuch sowie Ersatzteilleiste	Teil 2
Mode d'emploi, de maintenance et pièces de rechange	Partie 2
Manual de uso, mantenimiento y recambios	Part 2
Εγχειρίδιο χρήσης, συντήρησης και ανταλλακτικών	Μέρος 2
Manual de uso, manutenção e peças sobresselentes	Parte 2
Handleiding voor gebruik, onderhoud en wisselstukken	Deel 2
Kullanım, bakım ve yedek parça kılavuzu	Kısım 2
Användar-, underhålls- och reservdelshandbok	Del 2



PR.15

cod. 10802700



Dati tecnici Technical data Technische Daten Tekniska data	Caractéristiques techniques Datos técnicos Τεχνικά χαρακτηριστικά	Dados técnicos Technische gegevens Teknik veriler
--	---	---

Misure impiegabili Lengths Verwendbare Nagellänge Dimensioner som kan användas	Dimensions utiles Medidas de longitud Μήκος Αναλωσίμου	Medidas utilizáveis Toepasbare afmetingen Boy	10 ÷ 15
Capacità caricatore n° punti Magazine capacity Magazinkapazität: Nägel Magasinkapacitet: Antal punkter	Capacité chargeur n° de points Capacidad cargador n° puntos Δυνατότητα γεμιστέρα	Capacidade carregador n° pontos Capaciteit magazijn in aantal spijkers Dergi kapasitesi	200
Pressione d'esercizio Operating pressure Betriebsdruck Drifttryck	Pression d'exercice Presión de servicio Πίεση λειτουργίας	Pressão de serviço Werkdruk Çalışma basıncı	4 ÷ 7 bar 60 ÷ 100 psi
Consumo aria Air consumption Luftverbrauch Luftförbrukning	Consommation d'air Consumo aire Κατανάλωση αέρα	Consumo ar Luchtverbruik Hava tüketimi	0,10
Peso Weight Gewicht Vikt	Poids Peso Βάρος	Peso Gewicht Ağırlık	0,65
Dimensioni Dimensions Abmessungen Dimensioner (AxBxH)	Dimensions Dimensioes Διαστάσεις	Dimensões Afmetingen Boyutlar	200x33x148

EN 12549 :2009 EN ISO 4871 :2009	Pressione sonora in pos. operatore Sound pressure in operator's position Schalldruck am Arbeitsplatz Ljudtryck på operatörsplatsen	Pression sonore poste Opérateur Presión sonora en la pos. del operador Ηχητική πίεση στη θέση του χειριστή Operatör pozisyonunda ses basıncı	75 dB(A)
---	--	---	-----------------

EN 12549 :2009 EN ISO 3746 :2011 EN ISO 4871 :2009	Potenza sonora emessa Sound power emitted Emitierte Schalleistung Avgiven ljudeffekt	Puissance sonore émise Potencia sonora emitida Εκπεμπόμενη ηχητική ισχύς	Potência sonora emitida Geëmitteerd geluidsvermogen Çıkan ses gücü (ses desibel)	82 dB(A)
---	--	--	--	-----------------

CEN ISO/TS 8662-11 :2006 EN ISO 5349-2 :2004 EN 12096 :1999	Emissione vibratoria sull'impugnatura Vibratory emissions on handle Vibrationsemission am Griff Vibrationsemission på handtaget	Émission vibratoire sur la prise en main Emisión de vibraciones en la empuñadura Εκπεμπόμενες δονήσεις στη λαβή	Emissão vibratória na empunhadura Trillingsemissie op de handgreep Tutamak üzerindeki vibrasyon emisyonları	<2,5 m/s²
--	---	---	---	--------------------------------

Tipo di punto
Type of fastener
Befestigungsmittel
Type de rivet
Τύπος αναλωσίμου
Tipo de agrafa
Type nietjes
Zimba ve çivi tipleri

Pins 6

Ø 0,64

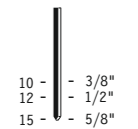

Wire dia: 0.025"
Gauge: 23

Parti di ricambio - Spare parts - Ersatzteile - Pièces de rechange - Recambios
Ανταλλακτικά - Partes sobresselentes - Wisselstukken - Yedek parçalar - Reservdelar

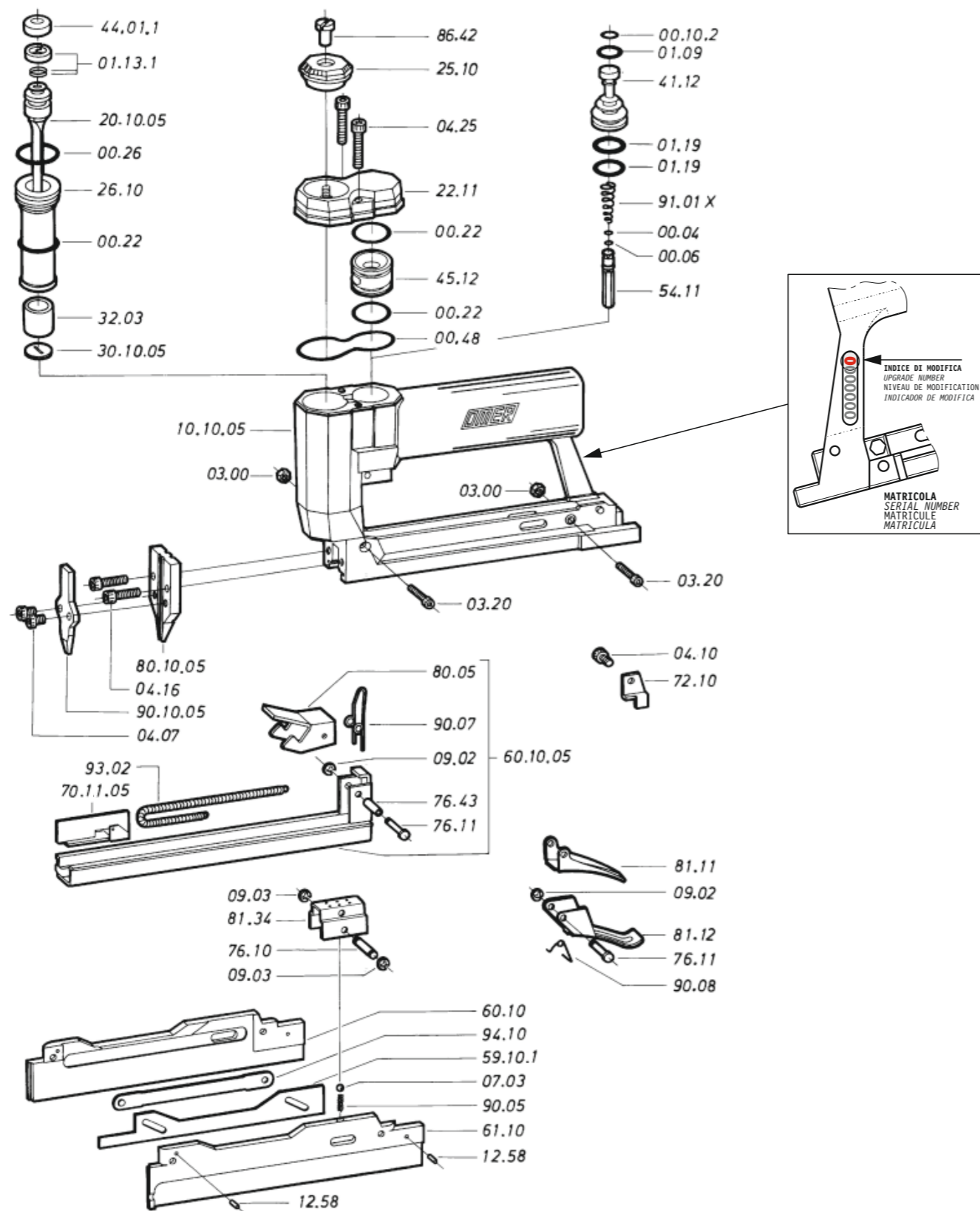

Dotazioni - Equipment - Ausstattung - Outillage - Dotaciones - Εξοπλισμός
Dotações - Uitrusting - Donanimlar - Utrustning



PR.15

cod. 10802700

Parti di ricambio - Spare parts - Ersatzteile - Pièces de rechange - Recambios
Ανταλλακτικά - Partes sobresselentes - Wisselstukken - Yedek parçalar - Reservdelar

Cod.	Descrizione	Description
00.04	O-Ring	O-Ring
00.06	O-Ring	O-Ring
00.10.2	O-Ring	O-Ring
00.22	O-Ring	O-Ring
00.26	O-Ring	O-Ring
00.48	O-Ring	O-Ring
01.09	O-Ring	O-Ring
01.13.1	Guarnizione	Gasket
01.19	O-Ring	O-Ring
03.00	Dado	Nut
03.20	Vite	Screw
04.07	Vite	Screw
04.10	Vite	Screw
04.16	Vite	Screw
04.25	Vite	Screw
07.03	Sfera	Ball
07.25	Chiave esagonale	Hex. Bar wrench
07.30	Chiave esagonale	Hex. Bar wrench
09.02	Anello elastico	Elastic ring
09.03	Anello elastico	Elastic ring
12.58	Spina	Pin
22.11	Testa	Head
25.10	Deflettore	Exhaust deflector
26.10	Cilindro	Cylinder
32.03	Ammortizzatore	Bumper
41.12	Pistone valvola	Valve
44.01.1	Ammortizzatore	Bumper
45.12	Anello valvola	Ring
54.11	Pulsante	Trigger valve
59.10.1	Regolatore	Adjusting
60.10	Guida Sx	Sx guide
61.10	Guida Dx	Dx guide
72.10	Fermo carrello	Slider stop
76.10	Perno	Pin
76.11	Perno	Pin
76.43	Perno	Pin
80.05	Grilletto chiusura	Trigger
81.11	Grilletto comando	Trigger
81.12	Controgrilletto	Safety
81.34	Leva regolazione	Adjusting lever
86.42	Vite deflettore	Deflector screw
90.05	Molla	Spring
90.07	Molla	Spring
90.08	Molla	Spring
91.01X	Molla	Spring
93.02	Molla	Spring
94.10	Tirante	Connecting rod
10.10.05	Corpo	Body
20.10.05	Battente	Driver
30.10.05	Rondella	Washer
60.10.05	Carrello	Slider
70.11.05	Spingipunto	Pusher
80.10.05	Controtestina	Nose
90.10.05	Testina	Nose plate

Guarnizioni - O-Rings - Dichtungen - Joints toriques - Juntas - Δοκτύλιος στεγανοποίησης - Vedantes - O-ringen - Contalar - O-ringar

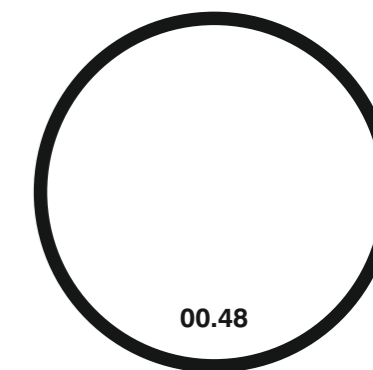
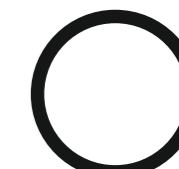
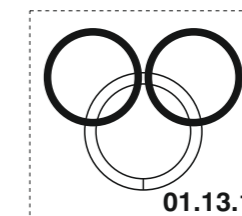

00.71.1

PR.15

cod. 10802700

Indice di modifica
Upgrade number

8

Disincippamento - Jam clearing - Staubeseitigung - Décoincement - Desatascamiento - Απεμπλοκή
Desencravamento - Deblokkering bij vastlopen - Sıkışma giderme - Rensning av igensättningar

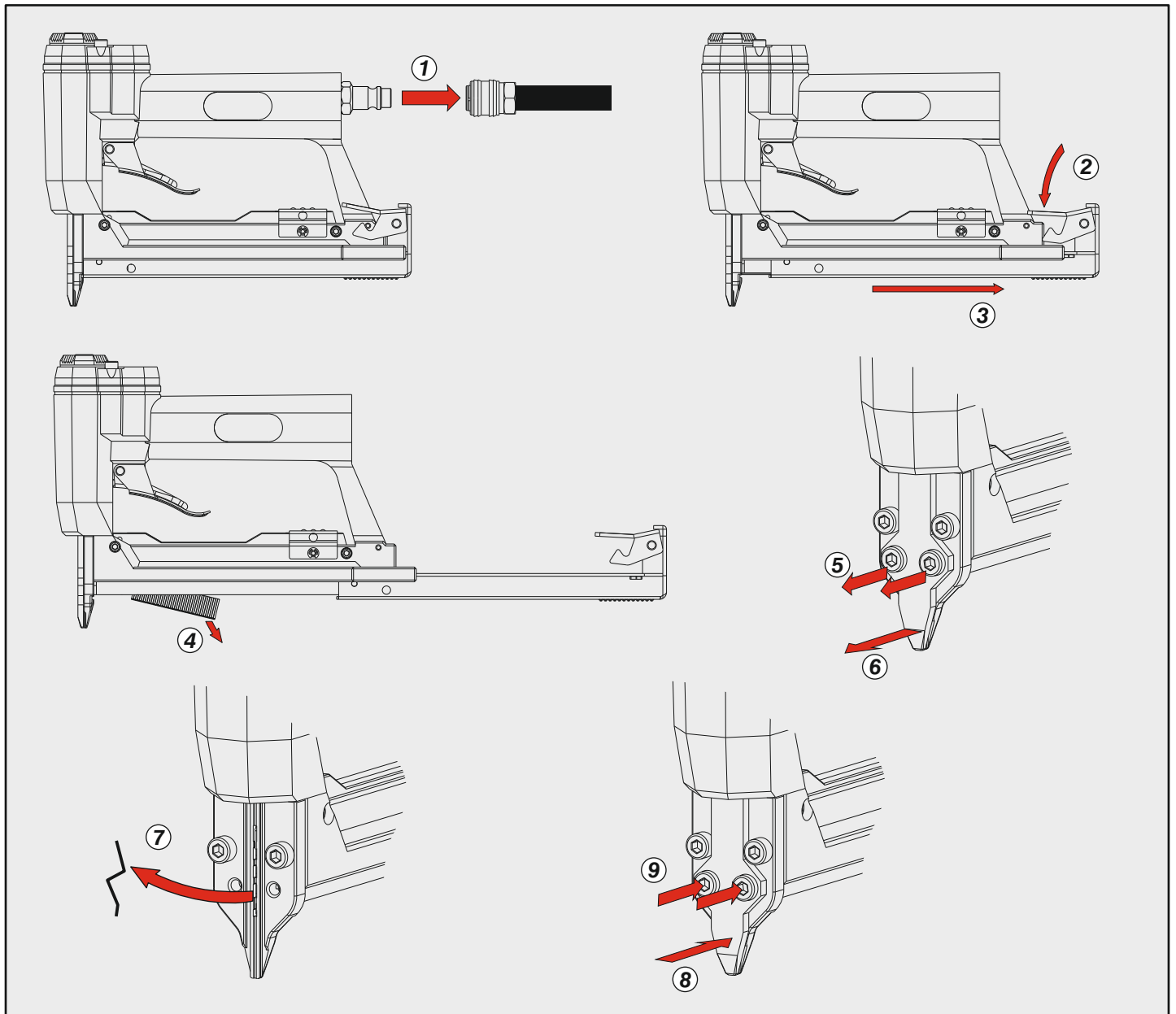

Caratteristiche - Features - Merkmale - Caractéristiques - Características
Χαρακτηριστικά - Características - Kenmerken - Özellikler - Funktionen

Scarico orientabile a 360°
360° adjustable exhaust

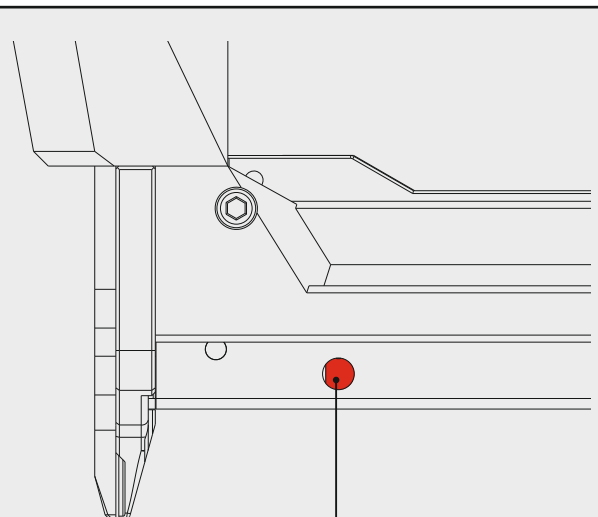
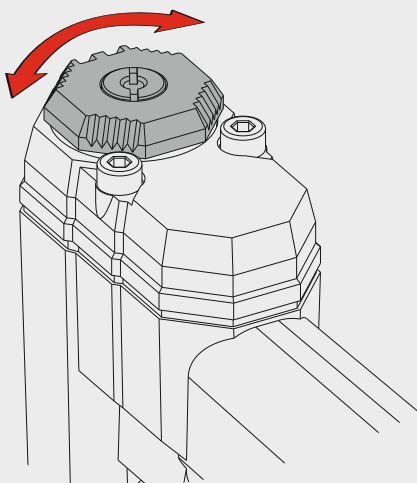

Sengnalatore di fine punti
Empty magazine flag