

# Schema di collegamento - Connecting diagram

Collegamento per valvola 3/2 NC  
Connection for valve 3/2 NC

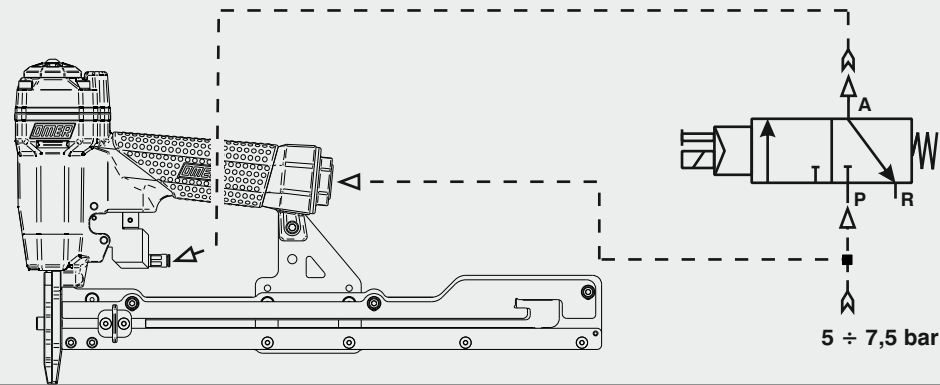

## Dotazioni - Equipment



## Caricamento - Loading

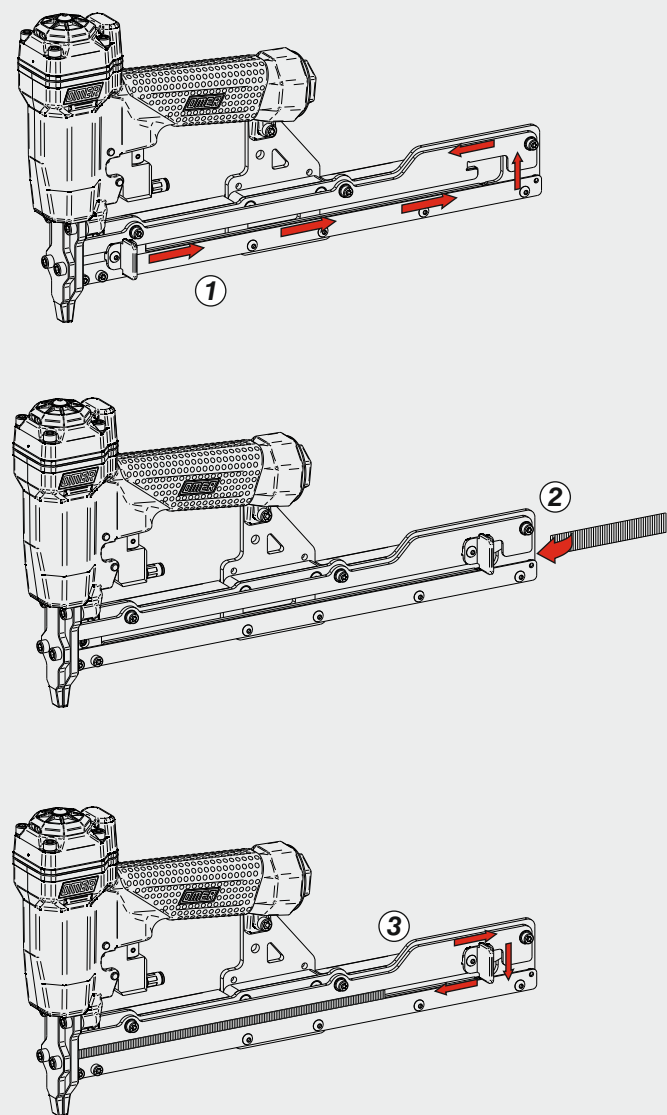

## Regolazione - Adjustment

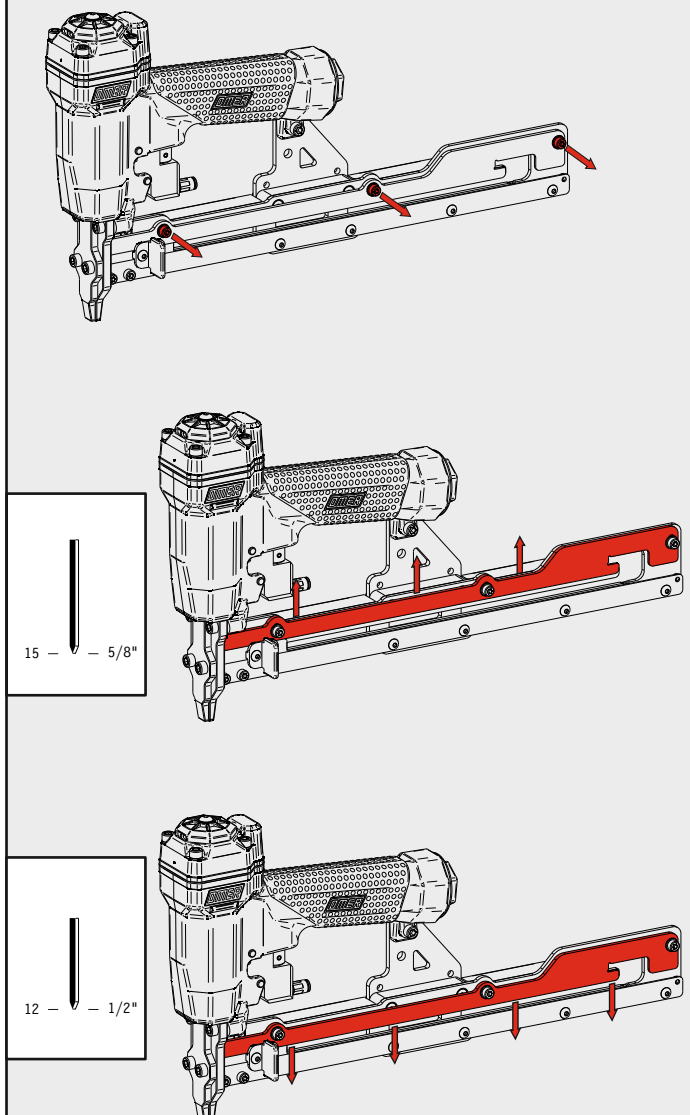

**Manuale d'uso, manutenzione e parti di ricambio**  
**Use, maintenance and spare parts manual**  
**Gebrauchsanweisung, Instandhaltungsrichtlinien und Ersatzteile**  
**Manuel d'utilisation, entretien et pièces de rechange**  
**Manual de uso, mantenimiento y repuestos**  
Εγχειρίδιο χρήσης, συντηρησης και ανταλλακτικών  
**Manual de utilização, manutenção e partes sobresselentes**  
**Handleiding voor gebruik, onderhoud en reservedeelslste**  
**Brugsanvisning, vedligeholdelse og reservedeelslste**

**Parte 2**  
**Part 2**  
**Teil 2**  
**Partie 2**  
**Part 2**  
2° Μερους  
**Parte 2**  
**Deel 2**  
**Del 2**

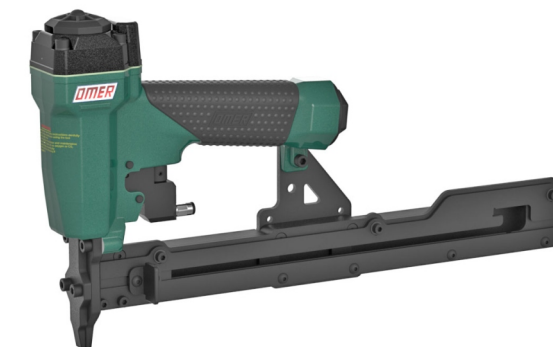

# RI.215 CL2-3

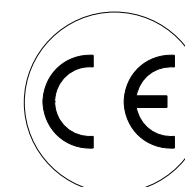

1220650-3\_RI215CL2-3\_2 150218 IV

cod. 1220650-3

Dati tecnici Technical data Technische daten	Données techniques Datos tècnicos Τεχνικά χαρακτηριστικά	Dados tècnicos Technischegegevens Tekniske data
--	--	---

<b>Misure impiegabili mm</b> Usable lengths mm Gebrauchliche Längen mm	Mesures utilisable mm Medidas que se pueden emplear mm Διαστάσεις σε μμ	Medidas que se podem utilizar mm Te gebruiken engtes in mm Brugbare laengder i mm	<b>12 • 15</b>
<b>Capacità caricatore n° punti</b> Magazine capacity No. of fasteners Magazinkapazität Nägel	Capacité chargeur n° de points Capacidad cargador n° puntos Δυνατότητα γεμιστερα, σωνδετερσε	Capacitade carregador n° pontos Capaciteit magazijn in aantal spijkers Kapacitet af magasin antal klemme	<b>210</b>
<b>Pressione d'esercizio</b> Working pressure Betriebsdruck	Pression de fonctionnement Presión de trabajo Πίεση λειτουργιασ ατμ.	Pressao de trabalho Werkdruk Arbejds tryk bar	<b>5 ÷ 7,5 bar</b> <b>70 ÷ 105 psi</b>
<b>Consumo aria litri/colpo</b> Air consumption litres/shot Luftverbrauch Liter/Schlag	Consommation air litre/coup Consumo aire-litros/golpe Καταναλοση αερα λ/ξτωπημα	Consumo ar litro/golpe Luchtverbruik liter/schot Luftforbrug liter/skud	<b>0,34</b>
<b>Peso kg</b> Weight kg Gewicht kg	Poids kg Peso kg Βαρος κγ	Peso kg Gewicht in kg Vaegt kg	<b>1,79</b>
<b>Dimensioni (AxBxH) mm</b> Dimensions mm Große mm	Dimension mm Dimensiones mm Δυνατοτητα γεμιστερα, σωνδετερσε	Dimencoes mm Afmetingen in mm Dimensioner mm	<b>388x50x215</b>

<b>EN 12549 :1999 ISO 11201 :1995</b>	<b>Pressione sonora in pos. operatore</b> Sound pressure at the workstation Lärmintensität am Arbeitsplatz	Pression acoustique près de l'opérateur Presión sonora en posición encargado Ακουστικη πιεση στη θεση χειριστου	Intensidade sonora perto do operador Geluidssterkte op de werkplek Lydstyrke på operatorposten	$L_{pA, 1s}$ (Rif. 20μPa) <b>78,8 dB(A)</b>
<b>EN 12549 :1999 ISO 3744 :1994</b>	<b>Potenza sonora emessa</b> Emitted sound power Ausgestrahlte Lärmintensität	Puissance acoustique émise Potencia sonora emitida Ακουστικη ισχυ	Potência sonora emitida Uitgestraalde geluidssterkte Udsendt lydstryke	$L_{WA, 1s}$ (Rif. 1pW) <b>88,5 dB(A)</b>

<b>EN 28662 :1992 ISO 5349 :1986 ISO 8662 -11</b>	<b>Valore medio ponderato di vibrazione sull'impugnatura</b> Weighted mean value of vibration on the grip Mitteler Vibrationswert, am Griff Gemessen	Valeur moyenne pondérée de vibration mesurée sur la poignée Valor medio ponderado de vibracion medida en la empunadura Μεσσοσ ορος μετρησις κραδασιων στη χειρολαβη	Valor medio ponderado de vibracao medida no punho Gewogen gemiddelde vibratiewaarde Middelvaardi af vibrationer pa handtaget	<b>&lt;2,5 m/s<sup>2</sup></b>
---	--	---	--	--------------------------------

**Tipo di punto**  
Type of fastener  
Befestigungselement  
Type d'agrafe  
Tipo de punto  
Τυπος καρφιου  
Tipo de ponto  
Type nietjes  
Tilspændingstype

### Pins I

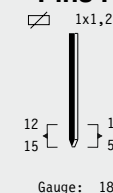

Parti di ricambio - Spare parts - Ersatzteile - Pièces de rechange - Piezas de repuesto  
Ανταλλακτικά - Partes sobresselentes - Tabel te raadplegen - Reservedele

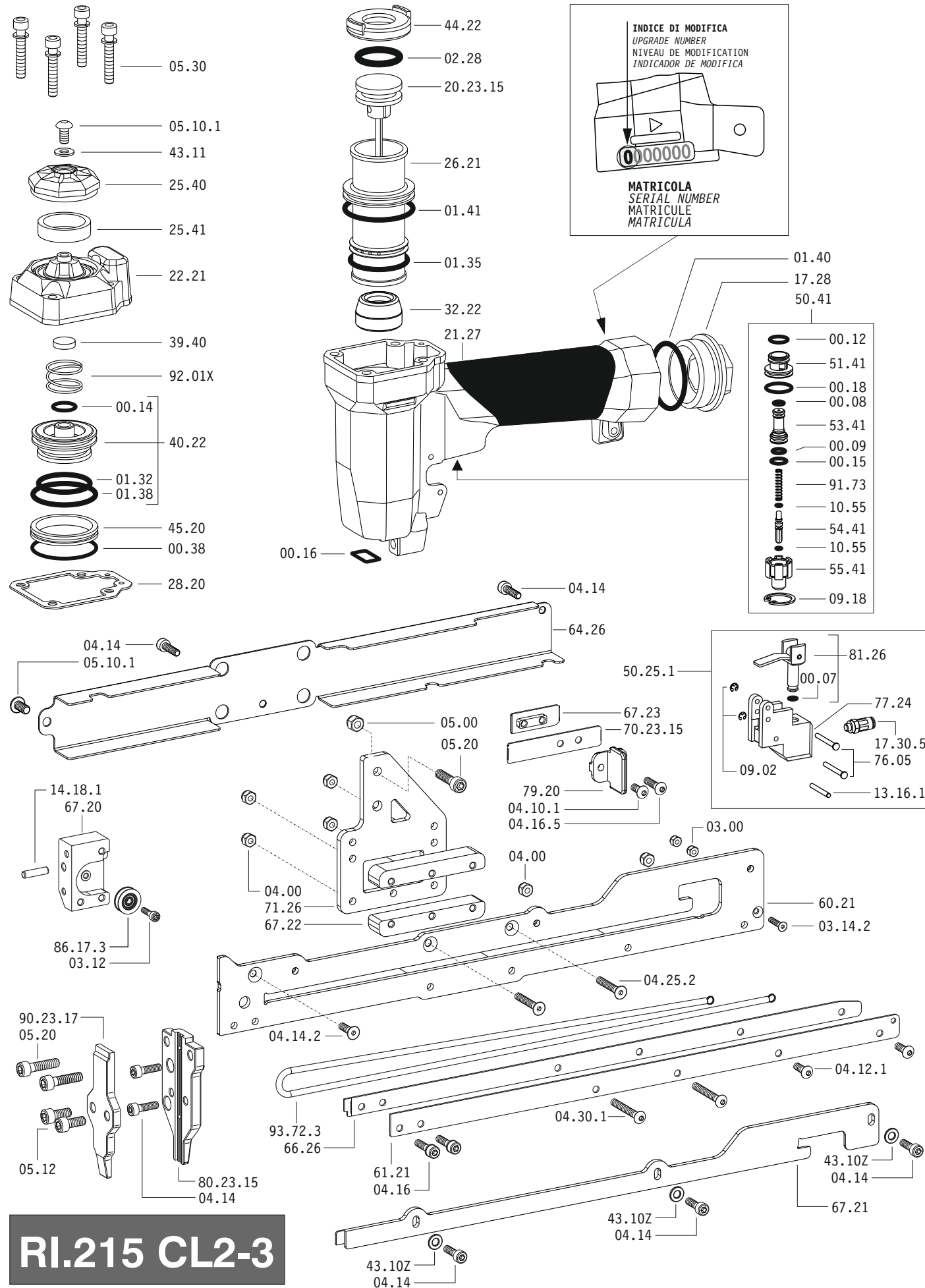

**RI.215 CL2-3**

cod. 1220650-3

Parti di ricambio - Spare parts - Ersatzteile - Pièces de rechange - Piezas de repuesto  
Ανταλλακτικά - Partes sobresselentes - Tabel te raadplegen - Reservedele

Cod.	Descrizione	Description
00.07	O-Ring	O-Ring
00.08	O-Ring	O-Ring
00.09	O-Ring	O-Ring
00.12	O-Ring	O-Ring
00.14	O-Ring	O-Ring
00.15	O-Ring	O-Ring
00.16	O-Ring	O-Ring
00.18	O-Ring	O-Ring
00.38	O-Ring	O-Ring
01.32	O-Ring	O-Ring
01.35	O-Ring	O-Ring
01.38	O-Ring	O-Ring
01.40	O-Ring	O-Ring
01.41	O-Ring	O-Ring
02.28	O-Ring	O-Ring
03.00	Dado	Nut
03.12	Vite	Screw
03.14.2	Vite	Screw
04.00	Dado	Nut
04.10.1	Vite	Screw
04.12.1	Vite	Screw
04.14	Vite	Screw
04.14.2	Vite	Screw
04.16	Vite	Screw
04.16.5	Vite	Screw
04.25.2	Vite	Screw
04.30.1	Vite	Screw
05.00	Dado	Nut
05.10.1	Vite	Screw
05.12	Vite	Screw
05.20	Vite	Screw
05.30	Vite	Screw
07.25	Chiave esagonale	Hex. bar wrench
07.30	Chiave esagonale	Hex. bar wrench
07.40	Chiave esagonale	Hex. bar wrench
09.02	Anello elastico	Elastic ring
09.18	Anello elastico	Elastic ring
10.55	O-Ring	O-Ring
13.16.1	Spina	Pin
14.18.1	Spina	Pin
17.28	Tappo	Inlet cap
17.30.5	Raccordo	Air plug
21.27	Corpo	Body
22.21	Testa	Head
25.40	Deflettore	Exhaust deflector
25.41	Silenziatore	Silencer
26.21	Cilindro	Cylinder
28.20	Guarnizione testa	Head gasket
32.22	Ammortizzatore	Bumper
39.40	Guarnizione scarico	Exhaust seal
40.22	Valvola completa	Valve ass'y
43.10Z	Rondella	Washer
43.11	Rondella	Washer
44.22	Guarnizione	Gasket
45.20	Anello valvola	Ring
50.25.1	Comando a distanza	Tremote trigger
50.41	Pulsante completo	Trigger valve ass'y
51.41	Boccola pulsante	Trigger valve housing
53.41	Pistone servovalvola	Valve piston
54.41	Pulsante	Trigger Valve
55.41	Raccordo pulsante	Bush
60.21	Guida sinistra	Left guide
61.21	Guida destra	Right guide
64.26	Carter	Carter
66.26	Distanziale	Spacer
67.20	Supporto	Support
67.21	Guida superiore	Upper guide
67.22	Distanziale	Spacer
67.23	Guida	Guide
71.26	Reggicaricatore	Support
76.05	Perno	Pin
77.24	Guida sicura	Safety trigger
79.20	Leva	Lever
81.26	Pistoncino	Piston
86.17.3	Carrucola	Pulley
91.73	Molla	Spring
92.01X	Molla	Spring
93.44	Molla	Spring
93.72.3	Molla	Spring
20.23.15	Battente	Driver
70.23.15	Spingipunto	Pusher
80.23.15	Controtestina	Nose
90.23.17	Testina	Nose plate
D01	Bocchetta olio	Oilier

Guarnizioni - O-Rings - Dichtungen - Joints - Kit O-Rings - Αρσπυγκία - Kit O-Rings - Pakninger

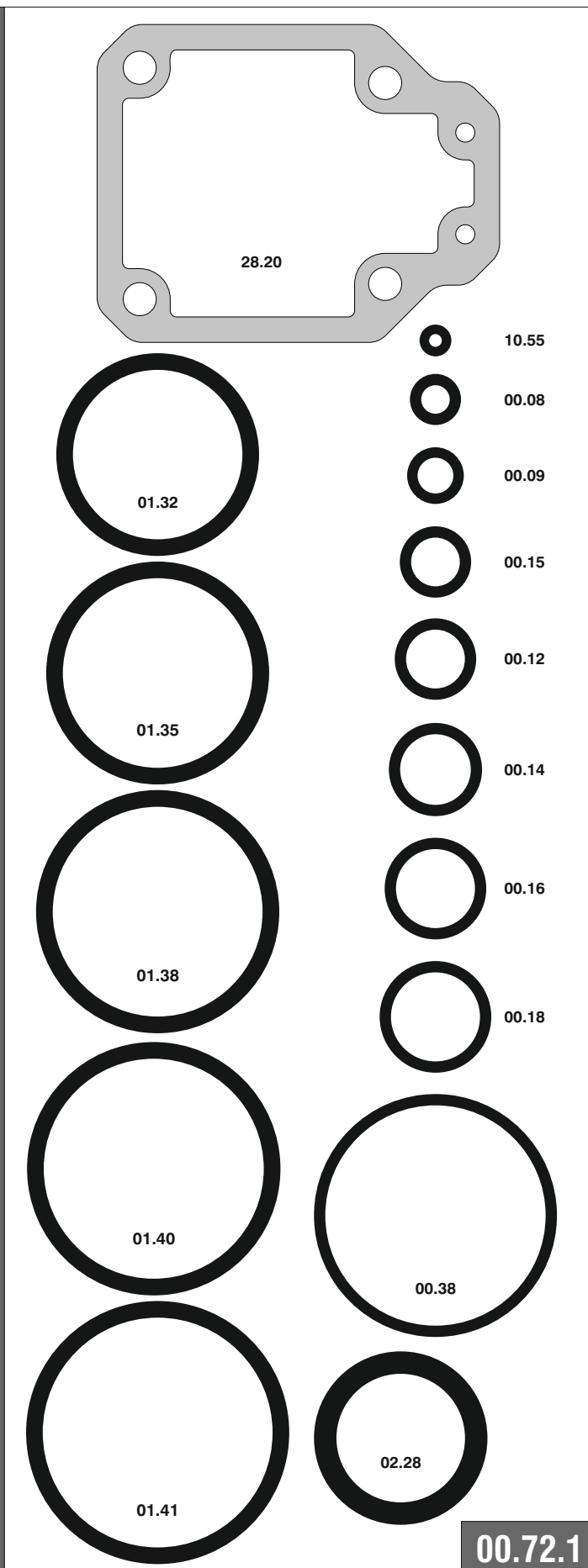

**RI.215 CL2-3**

cod. 1220650-3

Indice di modifica  
Upgrade number

**2**

2412913

1220650-3\_RI215CL2-3\_2\_150218 IV