

Funzionamento e Collegamento - Functioning and Connection

Funziamento: Functioning:

Azionare sia la sicura appoggiandoci il materiale da fissare sia la valvola comando
Actuate the safety by pressing the material to be fastened and the command valve

Collegamento: Connection:

Valvola 3/2 NC
Valve 3/2 NC

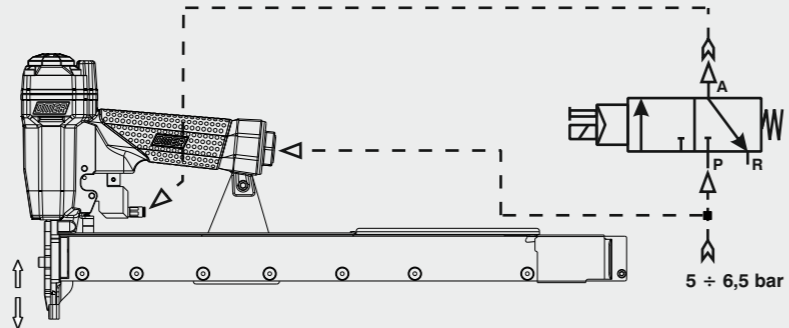

OMER

Manuale d'uso, manutenzione e parti di ricambio
Use, maintenance and spare parts manual
Gebrauchsanweisung, Instandhaltungsrichtlinien und Ersatzteile
Manuel d'utilisation, entretien et pièces de rechange
Manual de uso, mantenimiento y repuestos
Εγχειρίδιο χρήσης, συντηρησης και ανταλλακτικών
Manual de utilização, manutenção e partes sobresselentes
Handleiding voor gebruik, onderhoud en reservedelslste
Brugsanvisning, vedligeholdelse og reservedelslste

Parte 2
Part 2
Teil 2
Partie 2
Part 2
2° Μερους
Parte 2
Deel 2
Del 2



Caricamento - Loading

1 - Arretrare lo Spingipunto e agganciarlo al finecorsa
Pull the pusher backwards and lock it at the stop position at the rear of the tool

2 - Inserire i punti
Load the magazine with fastners

Non azionare MAI la valvola comando o la sicura a contatto durante il caricamento o il disinceppamento della graffatrice.
NEVER actuate the Command Valve or the contact safety while loading or cleaning a jammed stapler.

3 - Rilasciare lo Spingipunto
Release the the slider

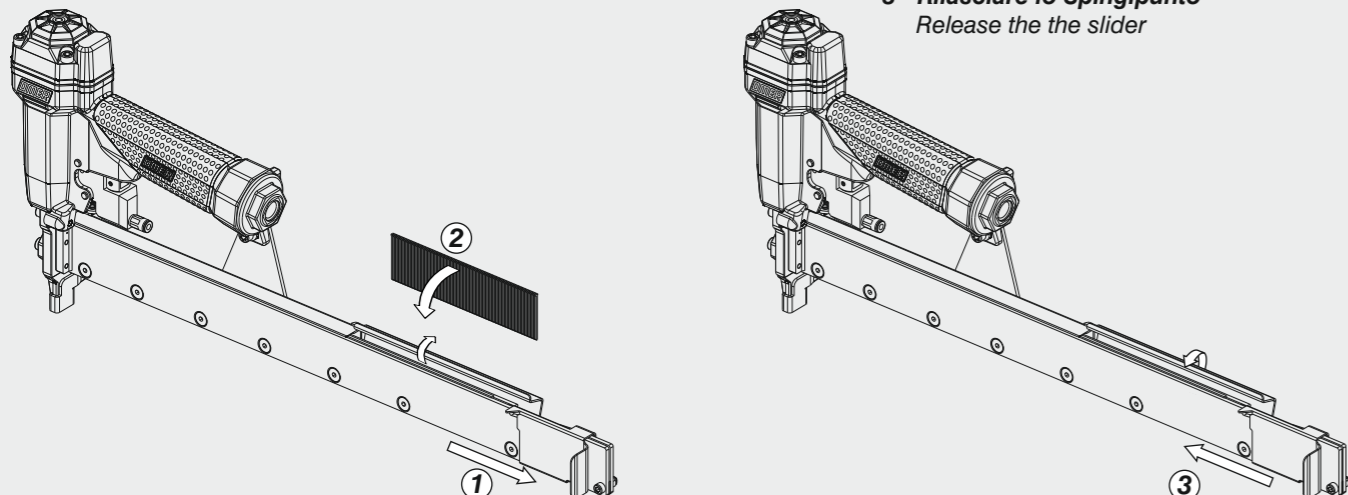

Disinceppamento macchina - Quick clearance jammed nails

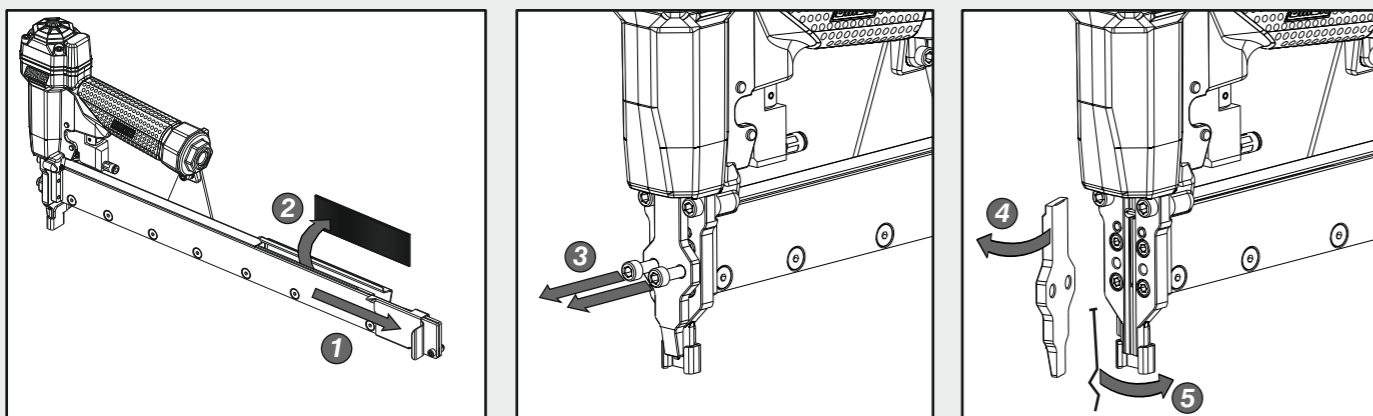

6 Riasssemblare in ordine inverso ed eseguire il caricamento
Reassemble in reverse order and load with fasteners

12214540_1425CLT4_2_091213_IV

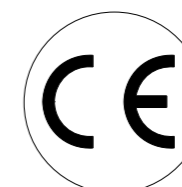

14.25 CLT4

cod. 12214540

Dati tecnici Technical data Technische daten	Données techniques Datos tècnicos Τεχνικά χαρακτηριστικά	Dados tècnicos Technischegegevens Teknische data
Misure impiegabili mm Usable lengths mm Gebrauchliche Längen mm	Mesures utilisable mm Medidas que se pueden emplear mm Διαστάσεις σε μμ	Medidas que se podem utilizar mm Te gebruiken engtes in mm Brugbare laengder i mm
Capacità caricatore n° punti Magazine capacity No. of fasteners Magazinkapazität Nägel	Capacité chargeur n° de points Capacidad cargador n° puntos Δυνατότητα γεμιστερα, σπινδτερες	Capacitade carregador n° pontos Capaciteit magazijn in aantal spijkers Kapacitet af magasin antal klemmme
Pressione d'esercizio Working pressure Betriebsdruck	Pression de fonctionnement Presión de trabajo Πιεση λειτουργιασ ατμ.	Pressao de trabalho Werkdruk Arbejds tryk bar
Consumo aria litri/colpo Air consumption litres/shot Luftverbrauch Liter/Schlag	Consommation air litre/coup Consumo aire-litros/golpe Καταναλοση αερα λ/ξτωπημα	Consumo ar litro/golpe Luchtverbruik liter/schot Luftforbrug liter/skud
Peso kg Weight kg Gewicht kg	Poids kg Peso kg Βαρος κγ	Peso kg Gewicht in kg Vaegt kg
Dimensioni (AxBxH) mm Dimensions mm Größe mm	Dimension mm Dimensiones mm Δυνατοτητα γεμιστερα, σπινδτερες	Dimencoes mm Afmetingen in mm Dimensioner mm
EN 12549 :1999 ISO 11201 :1995 Pressione sonora in pos. operatore Sound pressure at the workstation Lärmintensität am Arbeitsplatz	Pression acoustique près de l'opérateur Presión sonora en posición encargado Ακουστικη πιεση στη θεση χειριστου	Intensidade sonora perto do operador Geluidssterkte op de werkplek Lydstyrke på operatorposten
EN 12549 :1999 ISO 3744 :1994 Potenza sonora emessa Emitted sound power Ausgestrahlte Lärmintensität	Puissance acoustique émise Potencia sonora emitida Ακουστικη ισχυ	Potência sonora emitida Uitgestraalde geluidssterkte Udsendt lydstryke
EN 28662 :1992 ISO 5349 :1986 ISO 8662 -11 Valore medio ponderato di vibrazione sull'impugnatura Weighted mean value of vibration on the grip Mitteler Vibrationswert, am Griff Gemessen	Valeur moyenne pondérée de vibration mesurée sur la poignée Valor medio ponderado de vibracion medida en la empunadura Μεσσοσ ορος μετρησις κραδασιμων στη χειρολαβη	Valor medio ponderado de vibracao medida no punho Gewogen gemiddelde vibratiewaarde Middelvaardi af vibrationer pa handtaget

Tipo di punto
Type of fastener
Befestigungselement
Type d'agrafe
Tipo de punto
Τυπος κάρφιου
Tipo de ponto
Type nietjes
Tilspændingstype

Brads 14

1,40x1,60

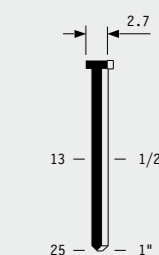

Head width: .108"
Thickness: .055"
Width: .063"
Gauge: 16

Parti di ricambio - Spare parts - Ersatzteile - Pièces de rechange - Piezas de repuesto
Ανταλλακτικά - Partes sobresselentes - Tabel te raadplegen - Reservedele

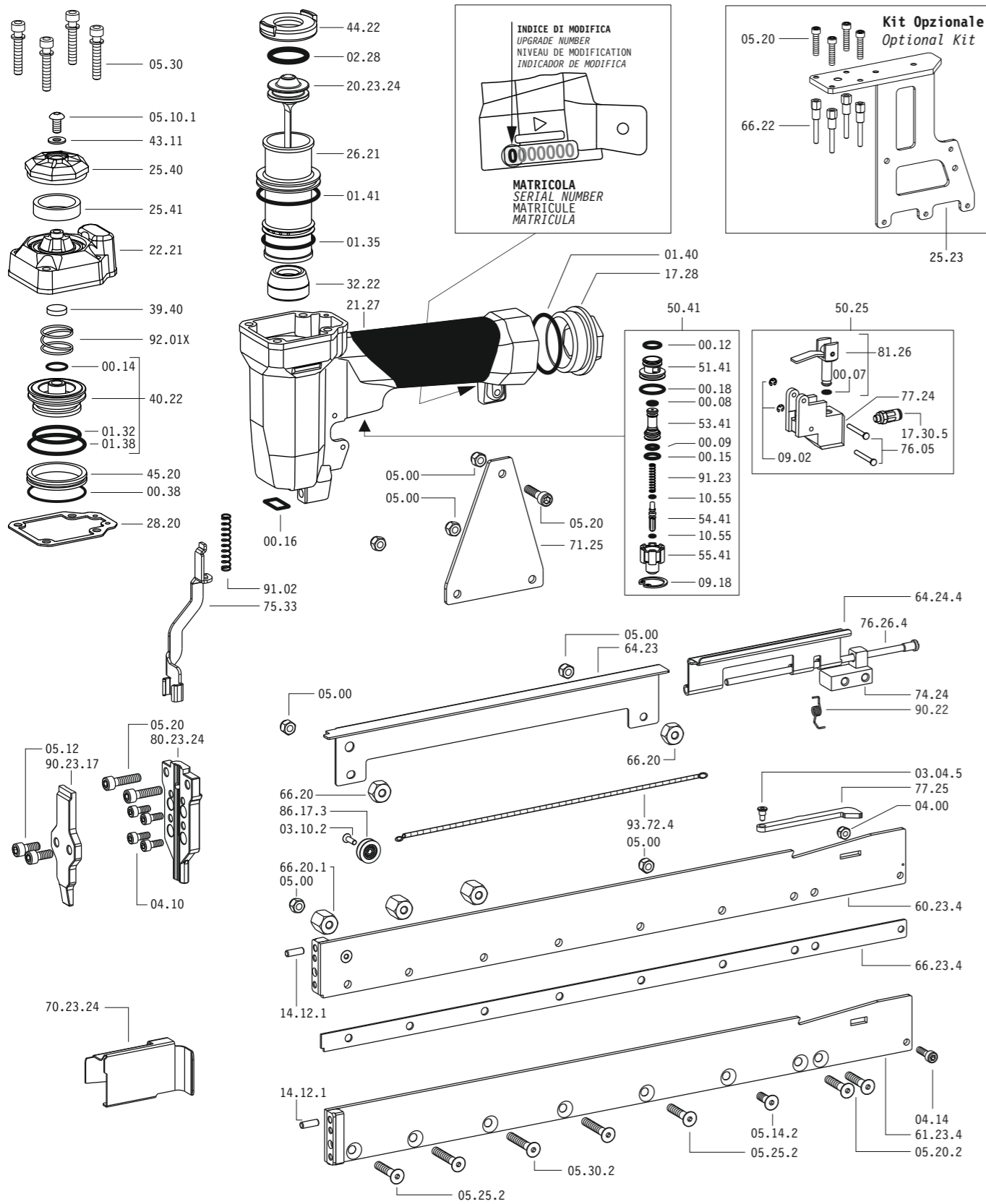

Dotazioni - Equipment - Ausrüstung - Équipements - Equipamiento - Παρεχόμενα
Equipamento - Uitrusting - Udstyr

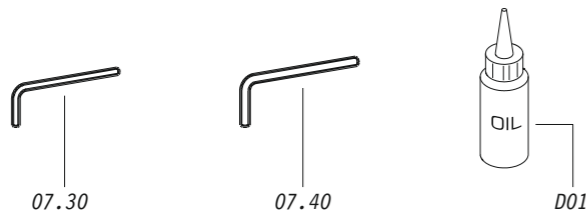

14.25 CLT4

cod. 12214540

Parti di ricambio - Spare parts - Ersatzteile - Pièces de rechange - Piezas de repuesto
Ανταλλακτικά - Partes sobresselentes - Tabel te raadplegen - Reservedele

Cod.	Descrizione	Description
00.07	O-Ring	O-Ring
00.08	O-Ring	O-Ring
00.09	O-Ring	O-Ring
00.12	O-Ring	O-Ring
00.14	O-Ring	O-Ring
00.15	O-Ring	O-Ring
00.16	O-Ring	O-Ring
00.18	O-Ring	O-Ring
00.38	O-Ring	O-Ring
01.32	O-Ring	O-Ring
01.35	O-Ring	O-Ring
01.38	O-Ring	O-Ring
01.40	O-Ring	O-Ring
01.41	O-Ring	O-Ring
02.28	O-Ring	O-Ring
03.04.5	Vite	Screw
03.10.2	Vite	Screw
04.00	Dado	Nut
04.10	Vite	Screw
04.14	Vite	Screw
05.00	Dado	Nut
05.10.1	Vite	Screw
05.12	Vite	Screw
05.14.2	Vite	Screw
05.20	Vite	Screw
05.20.2	Vite	Screw
05.25	Vite	Screw
05.25.2	Vite	Screw
05.30.2	Vite	Screw
05.30	Vite	Screw
07.30	Chiave esagonale	Hex. bar wrench
07.40	Chiave esagonale	Hex. bar wrench
09.02	Anello elastico	Elastic ring
09.18	Anello elastico	Elastic ring
10.55	O-Ring	O-Ring
14.12.1	Spina	Pin
17.28	Tappo	Inlet cap
17.30.5	Attacco	Connection
21.27	Corpo	Body
22.21	Testa	Head
25.23	Supporto	Support
25.40	Deflettore	Exhaust deflector
25.41	Silenziatore	Silencer
26.21	Cilindro	Cylinder
28.20	Guarnizione testa	Head gasket
32.22	Ammortizzatore	Bumper
39.40	Guarnizione scarico	Exhaust seal
40.22	Valvola completa	Valve ass'y
43.11	Rondella	Washer
44.22	Guarnizione	Gasket
45.20	Anello valvola	Ring
50.25	Comando a distanza	Remote control
50.41	Pulsante completo	Trigger valve ass'y
51.41	Boccola pulsante	Trigger valve housing
53.41	Pistone servovalvola	Valve piston
54.41	Pulsante	Trigger valve
55.41	Raccordo pulsante	Bush
60.23.4	Guida Sx	Left guide
61.23.4	Guida Dx	Right guide
64.23	Carter	Hold Down
64.24.4	Carter Mobile	Movable Hold Down
66.20	Distanziale	Spacer
66.20.1	Distanziale	Spacer
66.22	Distanziale	Spacer
66.23.4	Distanziale	Spacer
71.25	Reggicaricatore	Support
74.24	Staffa	Stirrup
75.33	Sicura	Safety
76.05	Perno	Pin
76.26.4	Perno carter	Pin
77.24	Guida	Guide
77.25	Leva	Lever
80.09	Grilletto chiusura	Trigger
81.26	Pistoncino	Piston
86.17.3	Carrucola	Pulley
90.22	Molla	Spring
91.02	Molla	Spring
91.23	Molla	Spring
92.01X	Molla	Spring
93.72.4	Molla	Spring
20.23.24	Battente	Driver
70.23.24	Spingipunto	Pusher
80.23.24	Controtestina	Nose
90.23.17	Testina	Nose plate
D01	Bocchetta olio	Oiler

Guarnizioni - O-Rings - Dichtungen - Joints - Kit O-Rings - Λαστιχάκια - Kit O-Rings - Pakninger

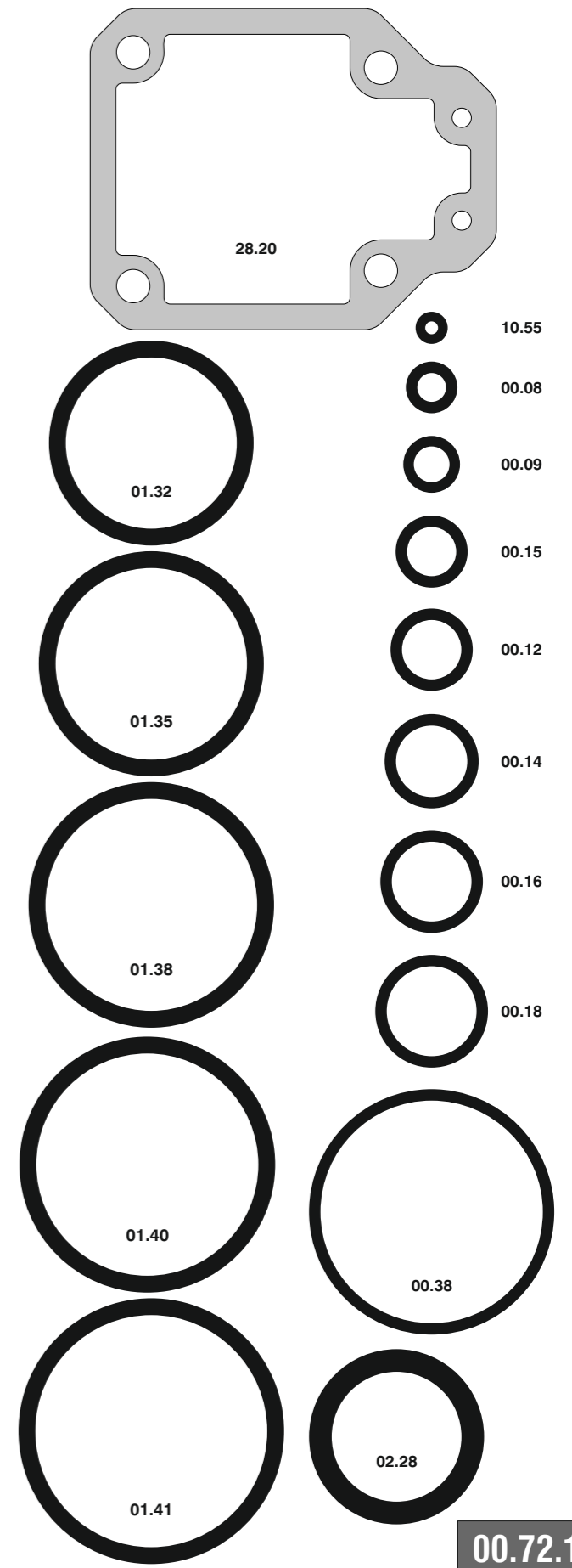

12214540_1425CLT4_2_091213 IV

14.25 CLT4

cod. 12214540

Indice di modifica
Upgrade number

2

2334076