

Caricamento - Loading

Carga dal balto Bottom load magazine

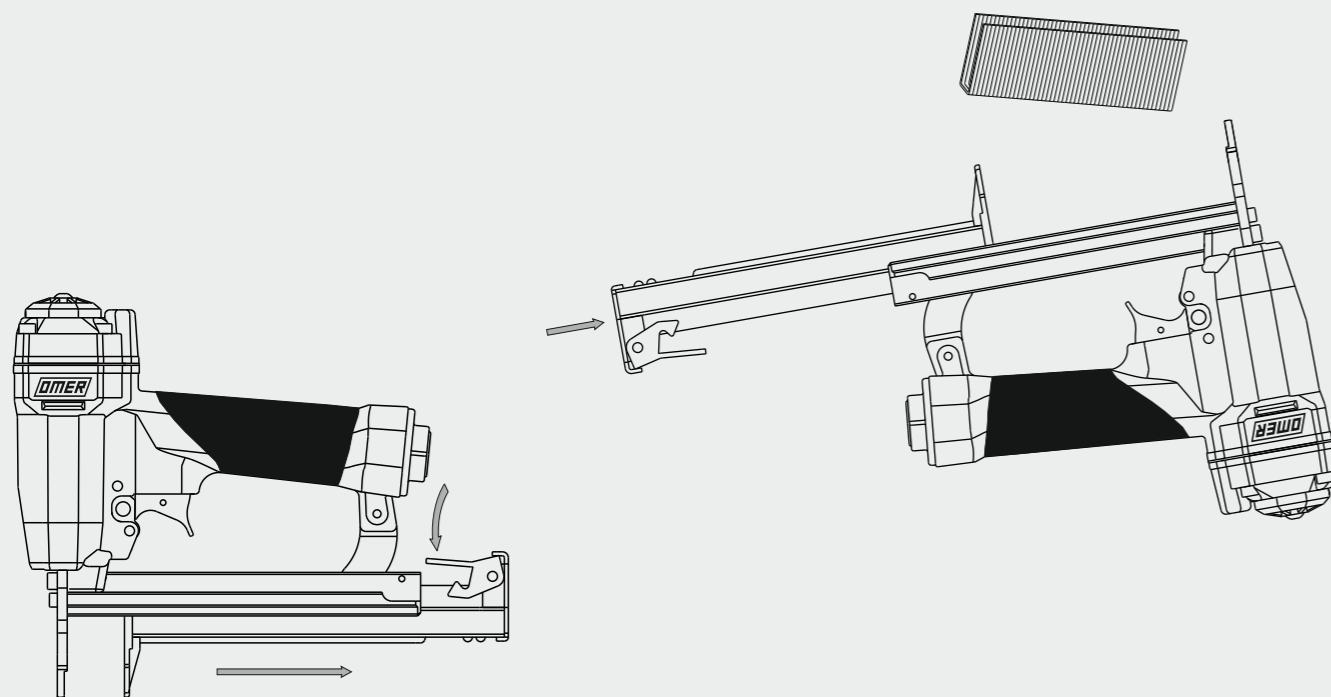

-Premere il grilletto chiusura

Press the magazine latch

-Arretrare il carrello

Pull the slider

-Capovolgere la graffatrice

Turn the tool up side down

-Inserire le graffe

Load the magazine with staples

-Chiudere il carrello

Shut the slider



Non azionare MAI il grilletto comando durante il caricamento della graffatrice.
NEVER pull the trigger or the contact safety while loading magazine.

OMER

Manuale d'uso, manutenzione e parti di ricambio

Use, maintenance and spare parts manual

Gebrauchsanweisung, Instandhaltungsrichtlinien und Ersatzteile

Manuel d'utilisation, entretien et pièces de rechange

Manual de uso, mantenimiento y repuestos

Εγχειρίδιο χρήσης, συντήρησης και ανταλλακτικών

Manual de utilização, manutenção e partes sobresselentes

Handleiding voor gebruik, onderhoud en reservedeelslijste

Brugsanvisning, vedligeholdelse og reservedeelsliste

Parte 2

Part 2

Teil 2

Partie 2

Part 2

2° Μερὸς

Parte 2

Deel 2

Del 2



4097.25 SS

cod. 1223000SS

1223000SS_409725SS_1 210613 IV

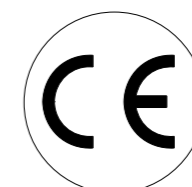

Dati tecnici

Technical data
Technische daten

Données techniques

Datos tècnicos
Τεχνικά χαρακτηριστικά

Dados tècnicos

Technische gegevens
Tecnische data

Misure impiegabili mm

Usable lengths mm
Gebrauchliche Längen mm

Mesures utilisables mm

Medidas que se pueden emplear mm
Διαστάσεις σε μμ

Medidas que se podem utilizar mm

Te gebruiken engtes in mm
Brugbare laengder i mm

12 ÷ 25

Capacità caricatore n° punti

Magazine capacity No. of fasteners
Magazinkapazität Nägel

Capacité chargeur n° de points

Capacidad cargador n° puntos
Δυνατότητα γεμιστέρα, σπινδύτερες

Capacidade carregador n° pontos

Capaciteit magazijn in aantal spijkers
Kapacitet af magasin antal klemme

135

Pressione d'esercizio

Working pressure
Betriebsdruck

Pression de fonctionnement

Presión de trabajo
Πίεση λειτουργίας ατμ.

Pressão de trabalho

Werkdruk
Arbejds tryk bar

5 ÷ 6,5 bar
70 ÷ 95 psi

Consumo aria litri/colpo

Air consumption litres/shot
Luftverbrauch Liter/Schlag

Consommation air litre/coup

Consumo aire-litros/golpe
Καταναλοση αερα λ/ξτῶπημα

Consumo ar litro/golpe

Luchtverbruik liter/schot
Luftforbrug liter/skud

0,31

Peso kg

Weight kg
Gewicht kg

Poids kg

Peso kg
Βαρος κγ

Peso kg

Gewicht in kg
Vaegt kg

1,15

Dimensioni (AxBxH) mm

Dimensions mm
Größe mm

Dimension mm

Dimensiones mm
Δυνατότητα γεμιστέρα, σπινδύτερες

Dimencoes mm

Afmetingen in mm
Dimensioner mm

226x50x204

EN 12549 :1999 ISO 11201 :1995

Pressione sonora in pos. operatore

Sound pressure at the workstation
Lärmintensität am Arbeitsplatz

Pression acoustique près de l'opérateur

Presión sonora en posición encargado
Ακουστική πίεση στη θέση χειριστού

Intensidade sonora perto do operador

Geluidssterkte op de werkplek
Lydstyrke på operatorposten

L_{pA,1s}
(Rif. 20μPa)

80,1 dB(A)

EN 12549 :1999 ISO 3744 :1994

Potenza sonora emessa

Emitted sound power
Ausgestrahlte Lärmintensität

Puissance acoustique émise

Potencia sonora emitida
Ακουστική ισχυ

Potência sonora emitida

Uitgestraalde geluidssterkte
Udsendt lydstyrke

L_{WA,1s}
(Rif. 1pW)

86,9 dB(A)

EN 28662 :1992 ISO 5349 :1986 ISO 8662 -11

Valore medio ponderato di vibrazione sull'impugnatura

Weighted mean value of vibration on the grip
Mitteler Vibrationswert, am Griff Gemessen

Valeur moyenne pondérée de vibration mesurée sur la poignée

Valor medio ponderado de vibracion medida en la empunadura
Μεσος ορος μετρησις κραδασμων στη χειρολαβη

Valor medio ponderado de vibracao medida no punho

Gewogen gemiddelde vibratiewaarde
Middelvaardi af vibrationer pa handtaget

<2,5 m/s²

Tipo di punto
Type of fastener
Befestigungselement
Type d'agrafe
Tipo de punto
Τυπος κάρφιου
Tipo de ponto
Type nietjes
Tilspændingstype

4097

0,65x0,95

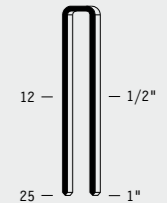

Gauge: 21

Crown: .170" (3/16")

40

0,65x0,95

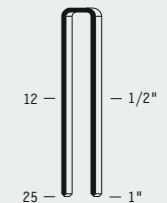

Gauge: 21

Crown: .180" (3/16")

Caratteristiche - Features

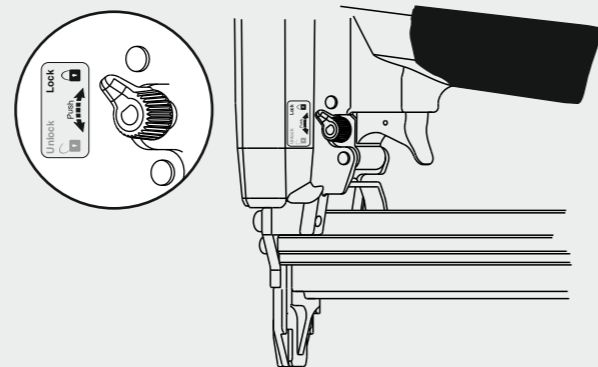
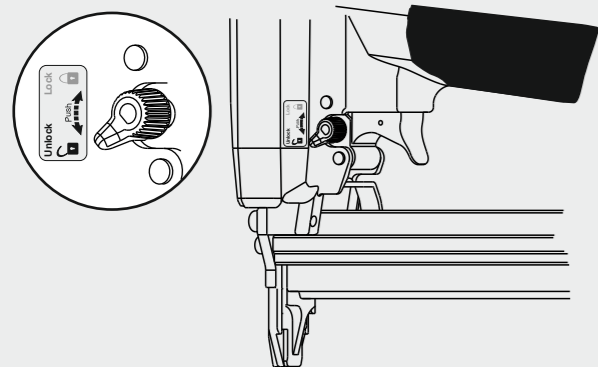

Parti di ricambio - Spare parts - Ersatzteile - Pièces de rechange - Piezas de repuesto
Ανταλλακτικά - Partes sobresselentes - Tabel te raadplegen - Reservedele

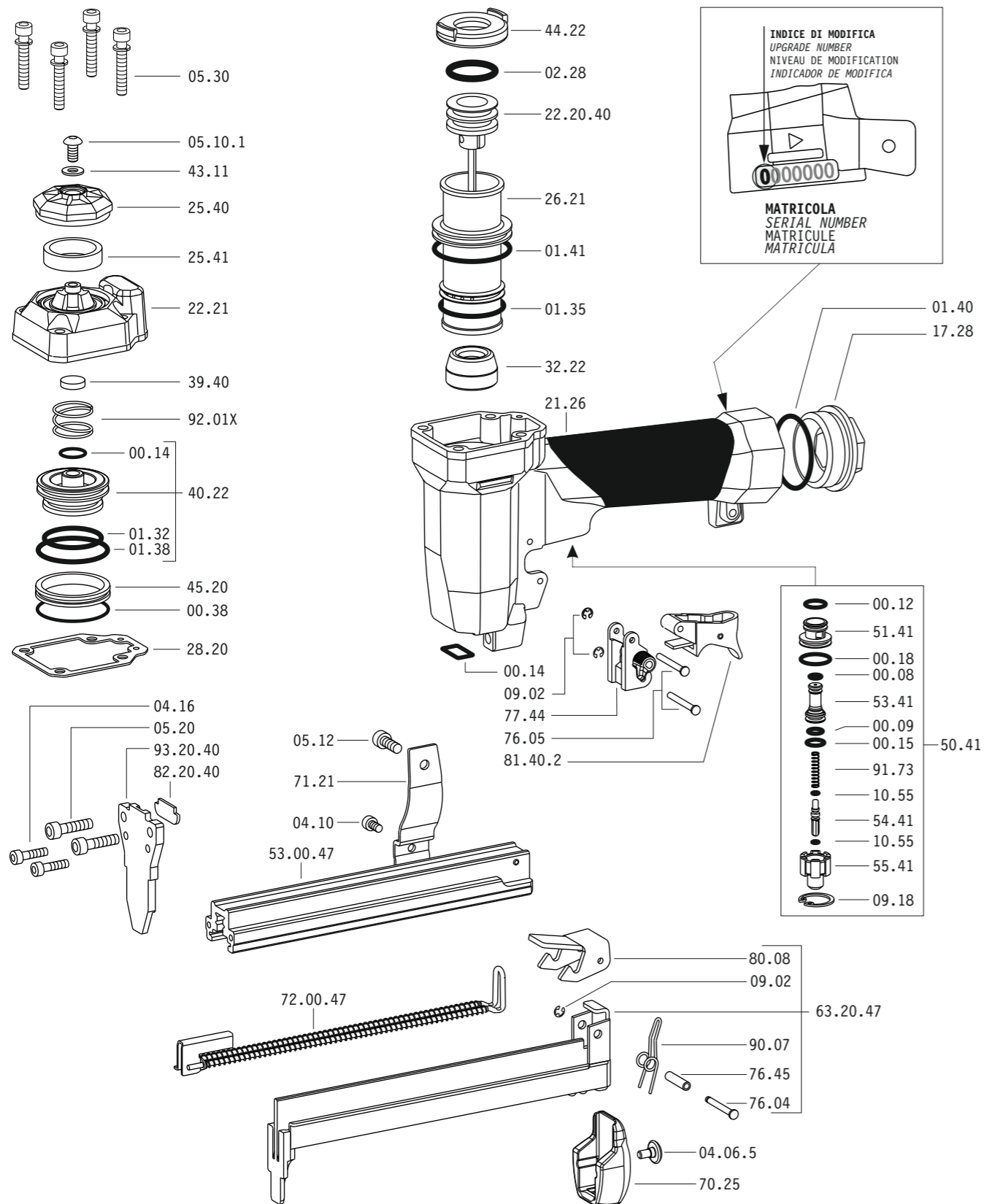

Dotazioni - Equipment - Ausrüstung - Équipements - Equipamiento - Παρεχόμενα
Equipamento - Uitrusting - Udstyr

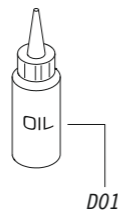

4097.25 SS

cod. 122300SS

Parti di ricambio - Spare parts - Ersatzteile - Pièces de rechange - Piezas de repuesto
Ανταλλακτικά - Partes sobresselentes - Tabel te raadplegen - Reservedele

Cod.	Descrizione	Description
00.08	O-Ring	O-Ring
00.09	O-Ring	O-Ring
00.12	O-Ring	O-Ring
00.14	O-Ring	O-Ring
00.15	O-Ring	O-Ring
00.18	O-Ring	O-Ring
00.38	O-Ring	O-Ring
01.32	O-Ring	O-Ring
01.35	O-Ring	O-Ring
01.38	O-Ring	O-Ring
01.40	O-Ring	O-Ring
01.41	O-Ring	O-Ring
02.28	O-Ring	O-Ring
04.06.5	Vite	Screw
04.10	Vite	Screw
04.16	Vite	Screw
05.10.1	Vite	Screw
05.12	Vite	Screw
05.20	Vite	Screw
05.30	Vite	Screw
07.30	Chiave esagonale	Hex. bar wrench
07.40	Chiave esagonale	Hex. bar wrench
09.02	Anello elastico	Elastic ring
09.18	Anello elastico	Elastic ring
10.55	O-Ring	O-Ring
17.28	Tappo	Inlet cap
21.26	Corpo	Body
22.21	Testa	Head
25.40	Deflettore	Exhaust deflector
25.41	Silenziatore	Silencer
26.21	Cilindro	Cylinder
28.20	Guarnizione testa	Head gasket
32.22	Ammortizzatore	Bumper
39.40	Guarnizione scarico	Exhaust seal
40.22	Valvola completa	Valve ass'y
43.11	Rondella	Washer
44.22	Guarnizione	Gasket
45.20	Anello valvola	Ring
50.41	Pulsante completo	Trigger valve ass'y
51.41	Boccola pulsante	Trigger valve housing
53.41	Pistone servovalvola	Valve piston
54.41	Pulsante	Trigger valve
55.41	Raccordo pulsante	Bush
70.25	Protezione	Guard
71.21	Reggicaricatore	Support
76.04	Perno	Pin
76.05	Perno	Pin
76.45	Perno molla	Pin
77.44	Guida sicura	Safety guide
80.08	Grilletto chiusura	Trigger
81.40.2	Grilletto comando	Trigger
90.07	Molla	Spring
91.73	Molla	Spring
92.01X	Molla	Spring
22.20.40	Battente	Driver
53.00.47	Caricatore	Magazine
63.20.47	Carrello	Slider
72.00.47	Spingipunto	Pusher
82.20.40	Controtestina	Nose
93.20.40	Testina	Nose plate
D01	Boccetta olio	Oiler

Guarnizioni - O-Rings - Dichtungen - Joints - Kit O-Rings - Αρστυχάκια - Kit O-Rings - O-ringen - Pakninger

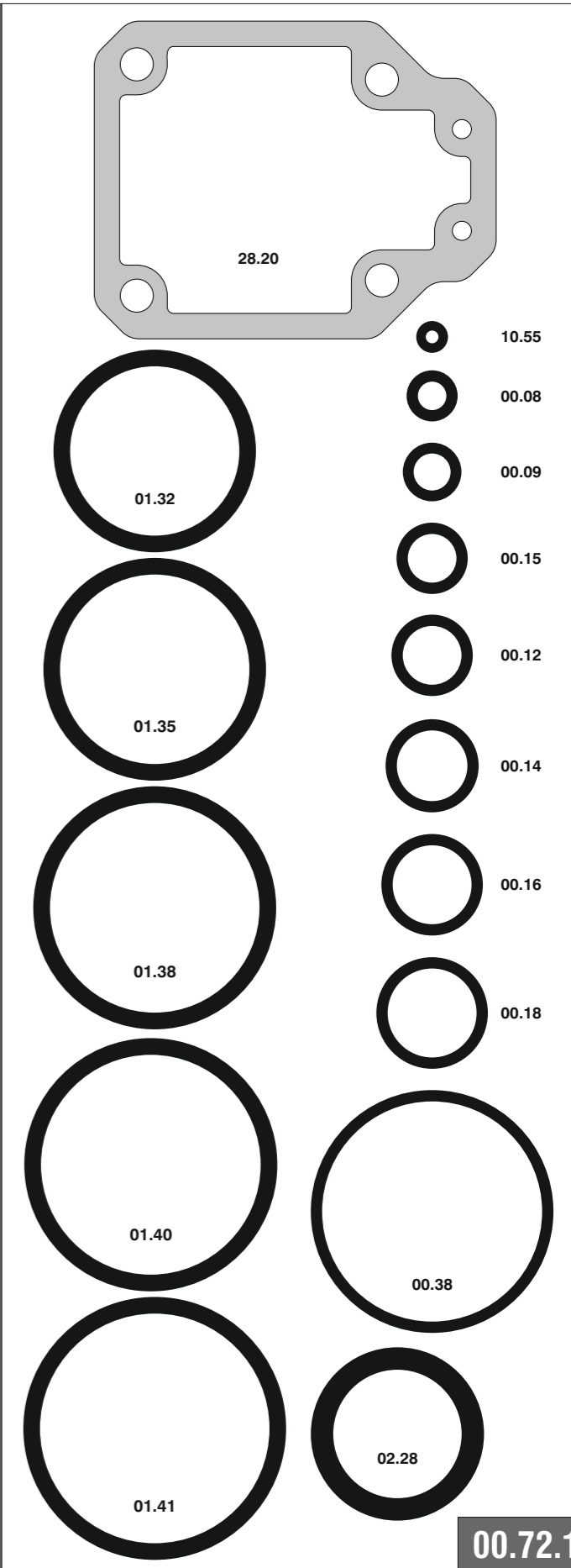

4097.25 SS cod. 122300SS

Indice di modifica Upgrade number

2

229521