

## Caricamento - Loading

### Caricamento da sotto Bottom load magazine

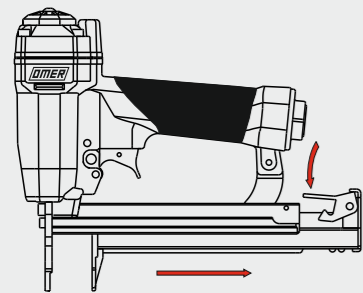

- Capovolgere la graffatrice  
Turn the tool up side down
- Inserire le graffe  
Load the magazine with staples
- Chiudere il carrello  
Shut the slider



**Non azionare MAI il grilletto comando durante il caricamento della graffatrice.**  
**NEVER pull the trigger while loading magazine.**

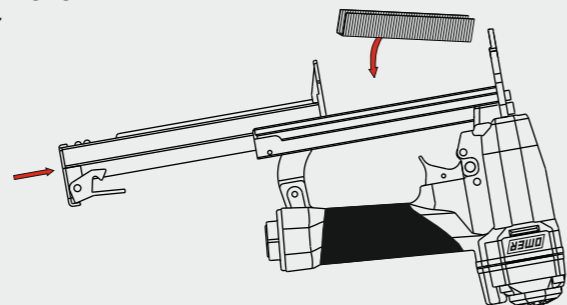

- Premere il grilletto chiusura  
Press the magazine latch
- Arretrare il carrello  
Pull the slider

## Funzionamento - Operating mode

### Automatica Auto-fire

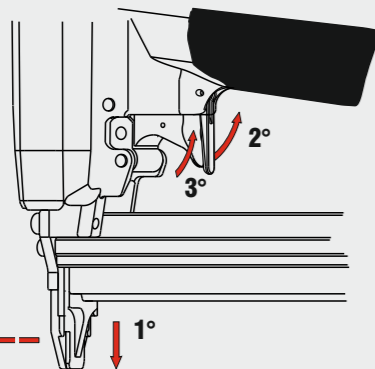
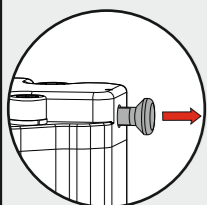

### Colpo singolo Single fire

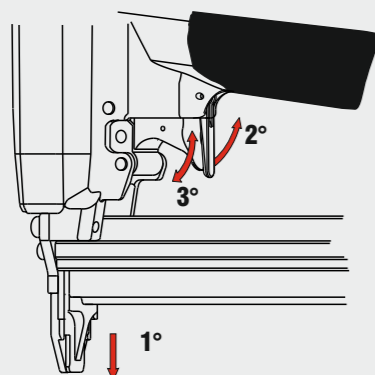
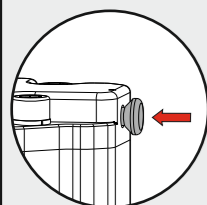

### Regolazione della velocità Speed adjustment

Max 1000 Cpm

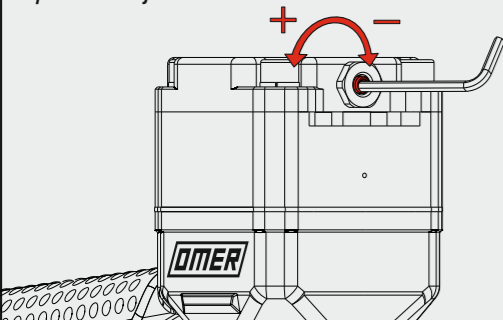

## Caratteristiche - Features

### Bloccata Locked

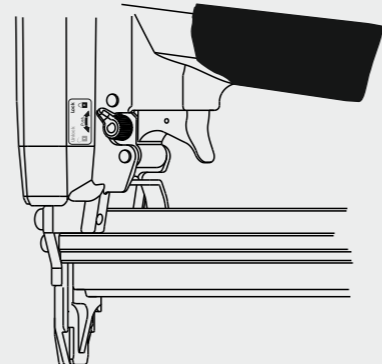
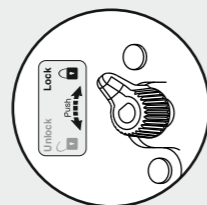

### Sbloccata Unlocked

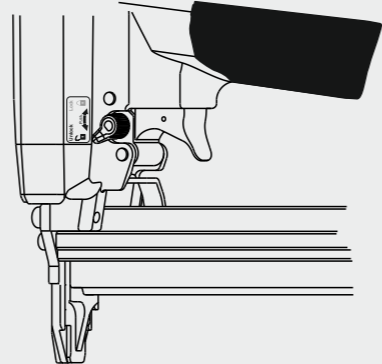
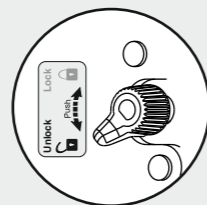

# OMER

**Manuale d'uso, manutenzione e parti di ricambio**  
**Use, maintenance and spare parts manual**  
**Gebrauchsanweisung, Instandhaltungsrichtlinien und Ersatzteile**  
**Manuel d'utilisation, entretien et pièces de rechange**  
**Manual de uso, mantenimiento y repuestos**  
Εγχειρίδιο χρήσης, συντήρησης και ανταλλακτικών  
**Manual de utilização, manutenção e partes sobresselentes**  
**Handleiding voor gebruik, onderhoud en reservedeelslijste**  
**Brugsanvisning, vedligeholdelse og reservedeelsliste**

**Parte 2**  
**Part 2**  
**Teil 2**  
**Partie 2**  
**Part 2**  
2° Μερως  
**Parte 2**  
**Deel 2**  
**Del 2**



# 83P.215 V

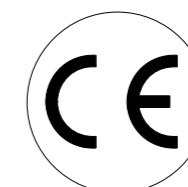

12263890\_83P215V\_2 191218 IV

cod. 12263890

Dati tecnici Technical data Technische daten	Données techniques Datos técnicos Τεχνικά χαρακτηριστικά	Dados técnicos Technischegegevens Tekniske data
--	--	---

<b>Misure impieghiabili mm</b> Usable lengths mm Gebrauchliche Längen mm	Mesures utilisable mm Medidas que se pueden emplear mm Διαστάσεις σε μμ	Medidas que se podem utilizar mm Te gebruiken engtes in mm Brugbare laengder i mm	<b>10 ÷ 15</b>
--	---	---	----------------

<b>Capacità caricatore n° punti</b> Magazine capacity No. of fasteners Magazinkapazität Nägel	Capacité chargeur n° de points Capacidad cargador n° puntos Δυνατότητα γεμιστερα, σπινδυτερας	Capacitate carregador n° pontos Capaciteit magazijn in aantal spijkers Kapacitet af magasin antal klemme	<b>70</b>
---	---	--	-----------

<b>Pressione d'esercizio</b> Working pressure Betriebsdruck	Pression de fonctionnement Presión de trabajo Πίεση λειτουργίας ατμ.	Pressao de trabalho Werkdruk Arbejds tryk bar	<b>5 ÷ 6,5 bar</b> <b>70 ÷ 95 psi</b>
---	--	---	--

<b>Consumo aria litri/colpo</b> Air consumption litres/shot Luftverbrauch Liter/Schlag	Consommation air litre/coup Consumo aire-litros/golpe Καταναλοση αερα λ/ξτωπημα	Consumo ar litro/golpe Luchtverbruik liter/schot Luftforbrug liter/skud	<b>0,31</b>
--	---	---	-------------

<b>Peso kg</b> Weight kg Gewicht kg	Poids kg Peso kg Βαρος κγ	Peso kg Gewicht in kg Vaegt kg	<b>1,22</b>
---	---------------------------------	--------------------------------------	-------------

<b>Dimensioni (AxBxH) mm</b> Dimensions mm Größe mm	Dimension mm Dimensiones mm Δυνατότητα γεμιστερα, σπινδυτερας	Dimencoes mm Afmetingen in mm Dimensioner mm	<b>244x50x223</b>
---	---	--	-------------------

<b>EN 12549 :1999 ISO 11201 :1995</b> <b>Pressione sonora in pos. operatore</b> Sound pressure at the workstation Lärmintensität am Arbeitsplatz	Pression acoustique près de l'opérateur Presión sonora en posición encargado Ακουστική πίεση στη θέση χειριστου	Intensidade sonora perto do operador Geluidssterkte op de werkplek Lydstyrke på operatorposten	$L_{pA,1s}$ (Rif. 20μPa) <b>80,1 dB(A)</b>
---	---	--	--

<b>EN 12549 :1999 ISO 3744 :1994</b> <b>Potenza sonora emessa</b> Emitted sound power Ausgestrahlte Lärmintensität	Puissance acoustique émise Potencia sonora emitida Ακουστική ισχυ	Potência sonora emitida Uitgestraalde geluidssterkte Udsendt lydstryke	$L_{WA,1s}$ (Rif. 1pW) <b>86,9 dB(A)</b>
---	---	--	--

<b>EN 28662 :1992 ISO 5349 :1986 ISO 8662 -11</b> <b>Valore medio ponderato di vibrazione sull'impugnatura</b> Weighted mean value of vibration on the grip Mitteler Vibrationswert, am Griff Gemessen	Valeur moyenne pondérée de vibration mesurée sur la poignée Valor medio ponderado de vibracion medida en la empunadura Μεσος ορος μετρησης κραδασμων στη χειρολαβη	Valor medio ponderado de vibracao medida no punho Gewogen gemiddelde vibratiewaarde Middelvaardi af vibrationer pa handtaget	<b>&lt;2,5 m/s<sup>2</sup></b>
--	--	--	--------------------------------

**Tipo di punto**  
Type of fastener  
Befestigungselement  
Type d'agrafe  
Tipo de punto  
Τυπος κάρφιου  
Tipo de ponto  
Type nietjes  
Tilspændingstype

**83P**

1,50x1,50

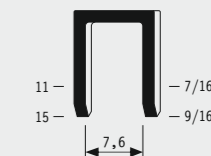

Crown: .420" 7/16"  
Gauge: 16

Parti di ricambio - Spare parts - Ersatzteile - Pièces de rechange - Piezas de repuesto  
Ανταλλακτικά - Partes sobresselentes - Tabel te raadplegen - Reservedele

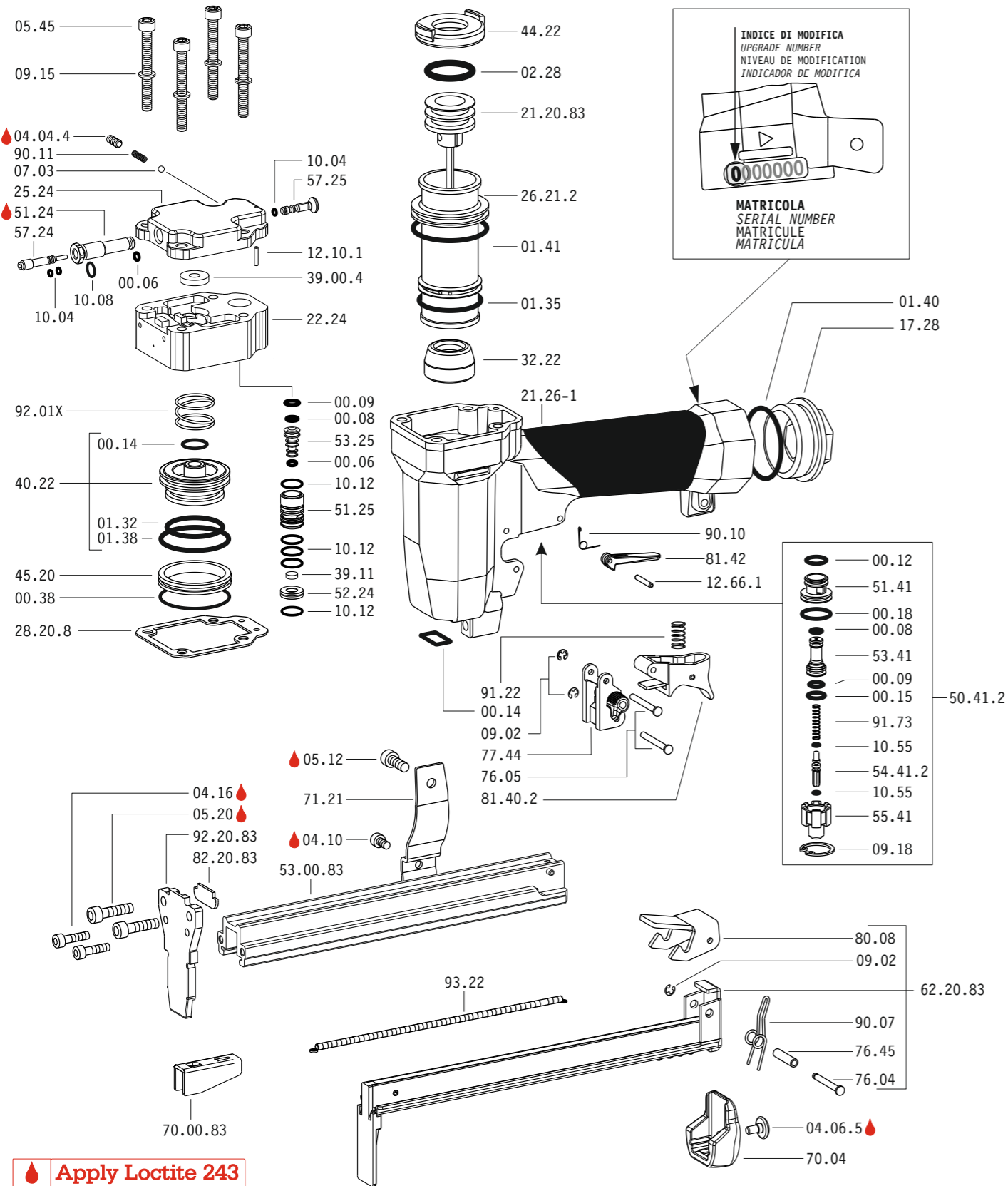

Apply Loctite 243

Dotazioni - Equipment - Ausrüstung - Équipements - Equipamiento - Παρεχόμενα  
Equipamento - Uitrusting - Udstyr

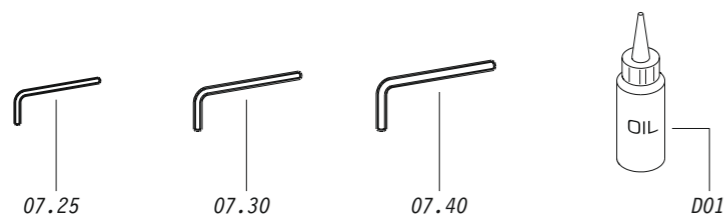

83P.215 V

cod. 12263890

Parti di ricambio - Spare parts - Ersatzteile - Pièces de rechange - Piezas de repuesto  
Ανταλλακτικά - Partes sobresselentes - Tabel te raadplegen - Reservedele

Cod.	Descrizione	Description
00.06	O-Ring	O-Ring
00.08	O-Ring	O-Ring
00.09	O-Ring	O-Ring
00.12	O-Ring	O-Ring
00.14	O-Ring	O-Ring
00.15	O-Ring	O-Ring
00.18	O-Ring	O-Ring
00.38	O-Ring	O-Ring
01.32	O-Ring	O-Ring
01.35	O-Ring	O-Ring
01.38	O-Ring	O-Ring
01.40	O-Ring	O-Ring
01.41	O-Ring	O-Ring
02.28	O-Ring	O-Ring
04.04.4	Vite	Screw
04.06.5	Vite	Screw
04.10	Vite	Screw
04.16	Vite	Screw
05.12	Vite	Screw
05.20	Vite	Screw
05.45	Vite	Screw
07.03	Sfera	Ball
07.25	Chiave esagonale	Hex. bar wrench
07.30	Chiave esagonale	Hex. bar wrench
07.40	Chiave esagonale	Hex. bar wrench
09.02	Anello elastico	Elastic ring
09.15	Rondella	Washer
09.18	Anello elastico	Elastic ring
10.04	O-Ring	O-Ring
10.08	O-Ring	O-Ring
10.12	O-Ring	O-Ring
10.55	O-Ring	O-Ring
12.66.1	Perno	Pin
12.10.1	Perno	Pin
17.28	Tappo	Inlet cap
21.26-1	Corpo	Body
22.24	Testa	Head
25.24	Deflettore	Exhaust deflector
26.21.2	Cilindro	Cylinder
28.20.8	Guarnizione testa	Head gasket
32.22	Ammortizzatore	Bumper
39.00.4	Guarnizione scarico	Exhaust seal
39.11	Guarnizione	Seal
40.22	Valvola completa	Valve ass'y
44.22	Guarnizione	Gasket
45.20	Anello valvola	Ring
50.41.2	Pulsante completo	Trigger valve ass'y
51.24	Boccola regolatore	Regulator valve housing
51.25	Cilindro servovalvola	Valve cylinder
51.41	Boccola pulsante	Trigger valve housing
52.24	Tappo	Stopper
53.25	Pistone servovalvola	Valve piston
53.41	Pistone servovalvola	Valve piston
54.41.2	Pulsante	Trigger valve
55.41	Raccordo pulsante	Bush
57.24	Regolatore	Regulator
57.25	Interruttore	Switch
70.04	Protezione	Guard
71.21	Reggicaricatore	Support
76.04	Perno	Pin
76.05	Perno	Pin
76.45	Perno molla	Pin
77.44	Guida sicura	Safety guide
80.08	Grilletto chiusura	Trigger
81.40.2	Grilletto comando	Trigger
81.42	Controgrilletto	Safety Trigger
90.07	Molla	Spring
90.10	Molla	Spring
90.11	Molla	Spring
91.22	Molla	Spring
91.73	Molla	Spring
92.01X	Molla	Spring
93.22	Molla	Spring
21.20.83	Battente	Driver
53.00.41	Caricatore	Magazine
62.20.83	Carrello	Slider
70.00.83	Spingipunto	Pusher
82.20.83	Controtestina	Nose
92.20.83	Testina	Nose plate
D01	Boccetta olio	Oiler

Guarnizioni - O-Rings - Dichtungen - Joints - Kit O-Rings - Αρσπυγκία - Kit O-Rings - Pakninger

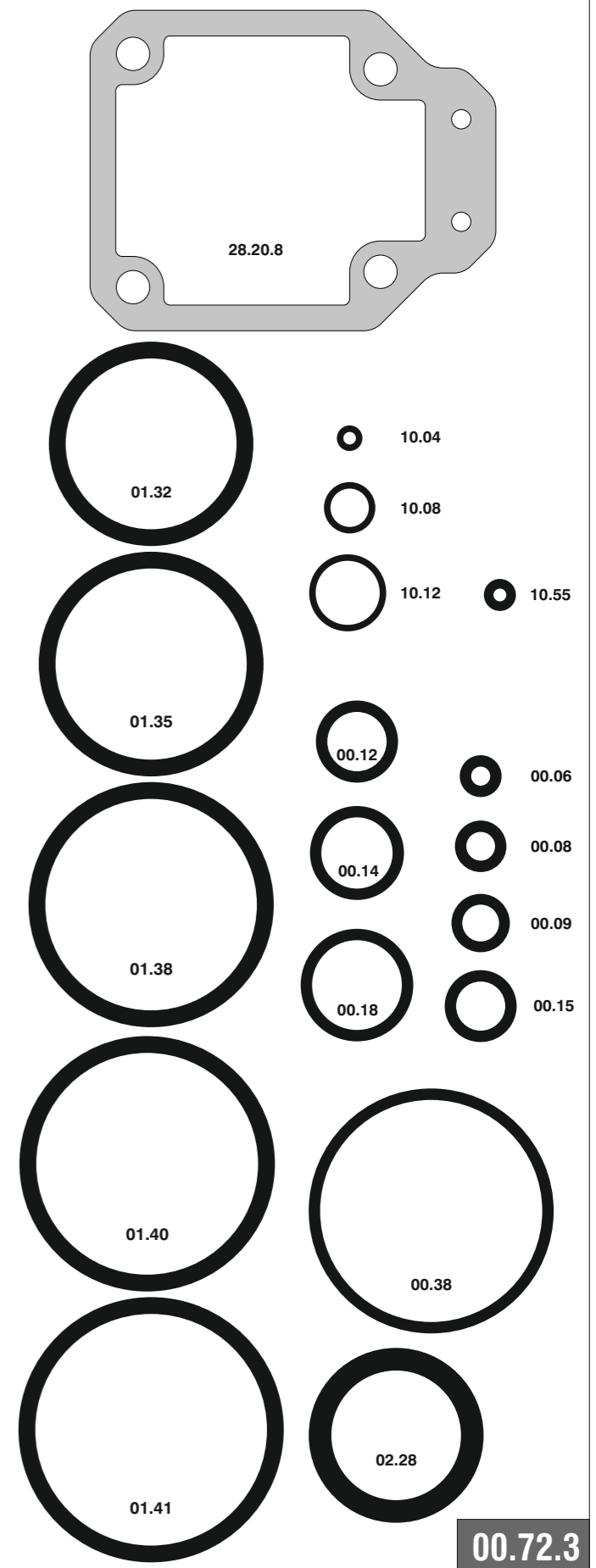

83P.215 V

cod. 12263890

Indice di modifica  
Upgrade number

2

2428373

00.72.3

12263890\_83P215V\_2\_191218\_IV