

Caricamento - Loading

Caricamento da sotto Bottom load magazine



Non azionare MAI il grilletto comando o la sicura a contatto durante il caricamento della graffatrice.
NEVER pull the trigger or the contact safety while loading magazine.

- Premere il grilletto chiusura
Press the magazine latch
- Arretrare il carrello
Pull the slider

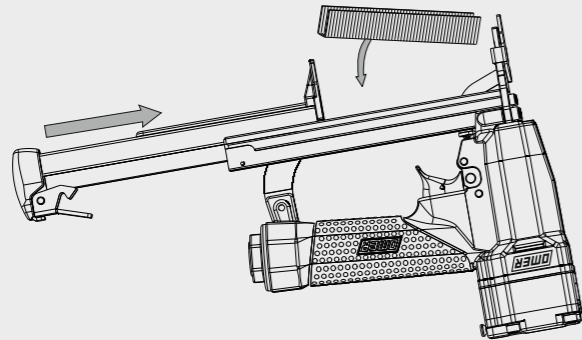
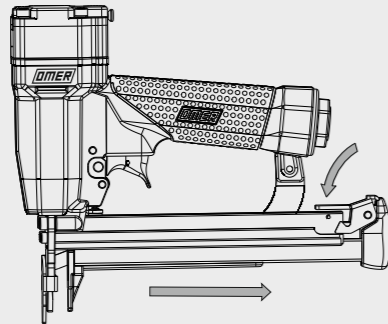

- Capovolgere la graffatrice
Turn the tool up side down
- Inserire le graffe
Load the magazine with staples
- Chiudere il carrello
Shut the slider



Manuale d'uso, manutenzione e parti di ricambio

Use, maintenance and spare parts manual

Gebrauchsanweisung, Instandhaltungsrichtlinien und Ersatzteile

Manuel d'utilisation, entretien et pièces de rechange

Manual de uso, mantenimiento y repuestos

Εγχειρίδιο χρήσης, συντήρησης και ανταλλακτικών

Manual de utilização, manutenção e partes sobresselentes

Handleiding voor gebruik, onderhoud en reservedeelslijste

Brugsanvisning, vedligeholdelse og reservedeelsliste

Parte 2

Part 2

Teil 2

Partie 2

Part 2

2° Μερὸς

Parte 2

Deel 2

Del 2



92.25 VD

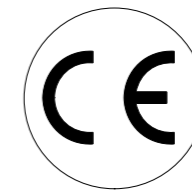

cod. 12272810

12272810_9225VD_2_191218 IV

Caratteristiche - Features

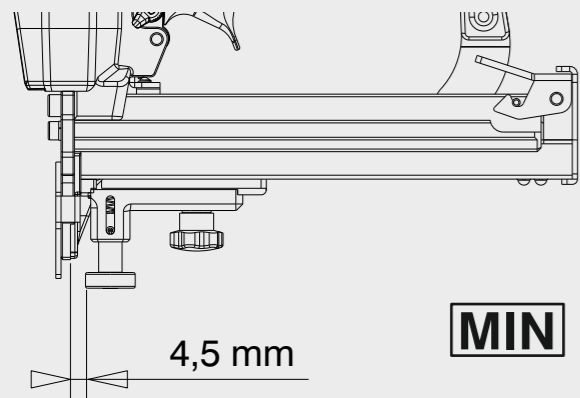

MIN

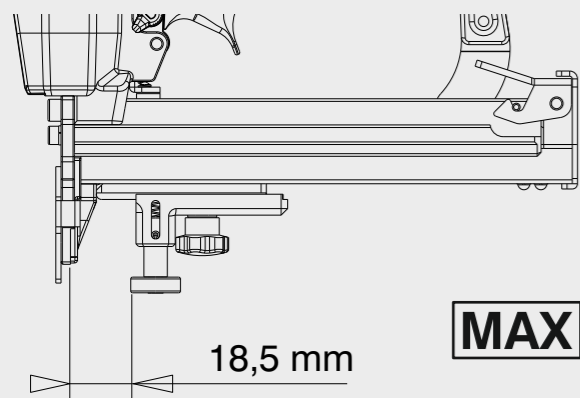

MAX

Regolazione distanziale Spacer adjusting

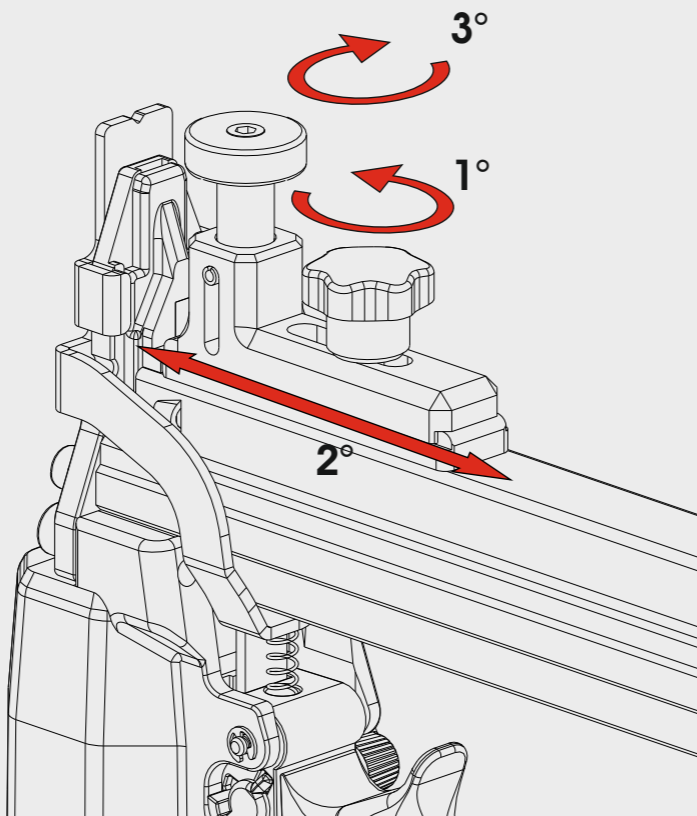

Dati tecnici Technical data Technische daten	Données techniques Datos tècnicos Τεχνικά χαρακτηριστικά	Dados tècnicos Technischegegevens Tekniske data
--	--	---

Misure impieghiabili mm Usable lengths mm Gebrauchliche Längen mm	Mesures utilisable mm Medidas que se pueden emplear mm Διαστάσεις σε μμ	Medidas que se podem utilizar mm Te gebruiken engtes in mm Brugbare laengder i mm	9÷25
--	---	---	-------------

Capacità caricatore n° punti Magazine capacity No. of fasteners Magazinkapazität Nägel	Capacité chargeur n° de points Capacidad cargador n° puntos Δυνατότητα γεμιστέρα, σπινδύτερες	Capacidade carregador n° pontos Capaciteit magazijn in aantal spijkers Kapacitet af magasin antal klemme	100
---	---	--	------------

Pressione d'esercizio Working pressure Betriebsdruck	Pression de fonctionnement Presión de trabajo Πίεση λειτουργίας ατμ.	Pressao de trabalho Werkdruk Arbejds tryk bar	5,5÷7,5 bar 80÷105 psi
---	--	---	-----------------------------------

Consumo aria litri/colpo Air consumption litres/shot Luftverbrauch Liter/Schlag	Consommation air litre/coup Consumo aire-litros/golpe Καταναλοση αερα λ/ξτῶπημα	Consumo ar litro/golpe Luchtverbruik liter/schot Luftforbrug liter/skud	0,31
--	---	---	-------------

Peso kg Weight kg Gewicht kg	Poids kg Peso kg Βαρος κγ	Peso kg Gewicht in kg Vaegt kg	1,36
---	---------------------------------	--------------------------------------	-------------

Dimensioni (AxBxH) mm Dimensions mm Größe mm	Dimension mm Dimensiones mm Δυνατότητα γεμιστέρα, σπινδύτερες	Dimencoes mm Afmetingen in mm Dimensioner mm	226x50x227
---	---	--	-------------------

EN 12549 :1999 ISO 11201 :1995 Pressione sonora in pos. operatore Sound pressure at the workstation Lärmintensität am Arbeitsplatz	Pression acoustique près de l'opérateur Presión sonora en posición encargado Ακουστική πίεση στη θέση χειριστού	Intensidade sonora perto do operador Geluidssterkte op de werkplek Lydstyrke på operatorposten	$L_{pA,1s}$ (Rif. 20μPa) 80,1 dB(A)
---	---	--	--

EN 12549 :1999 ISO 3744 :1994 Potenza sonora emessa Emitted sound power Ausgestrahlte Lärmintensität	Puissance acoustique émise Potencia sonora emitida Ακουστική ισχυ	Potência sonora emitida Uitgestraalde geluidssterkte Udsendt lydstryke	$L_{WA,1s}$ (Rif. 1pW) 86,9 dB(A)
---	---	--	--

EN 28662 :1992 ISO 5349 :1986 ISO 8662 -11 Valore medio ponderato di vibrazione sull'impugnatura max.1000 colpi Weighted mean value of vibration on the grip max.1000 shots Mittler Vibrationswert, am Griff gemessen max.1000 Schäge	Valeur moyenne pondérée de vibration mesurée sur la poignée max.1000 coups Valor medio ponderado de vibracion medida en la empunadura max.1000 golp Μεσος ορος μετρησις κραδασιμων στη χειρολαβη μαξ.1000 ξτῶπημα	Valor medio ponderado de vibracao medida no punho max.1000 golpes Gewogen gemiddelde vibratiewaarde max.1000 schot Middelvaardi af vibrationer pa handtaget max.1000 skud	8,2 m/s²
--	---	---	-----------------

Tipo di punto
Type of fastener
Befestigungselement
Type d'agrafe
Tipo de punto
Τυπος κάρφιου
Tipo de ponto
Type nietjes
Tilspændingstype

92

1,00x1,25

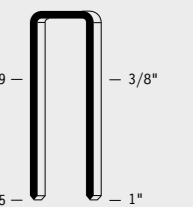

Gauge: 18
Crown: .330" (5/16")

Parti di ricambio - Spare parts - Ersatzteile - Pièces de rechange - Piezas de repuesto
Ανταλλακτικά - Partes sobresselentes - Tabel te raadplegen - Reservedele

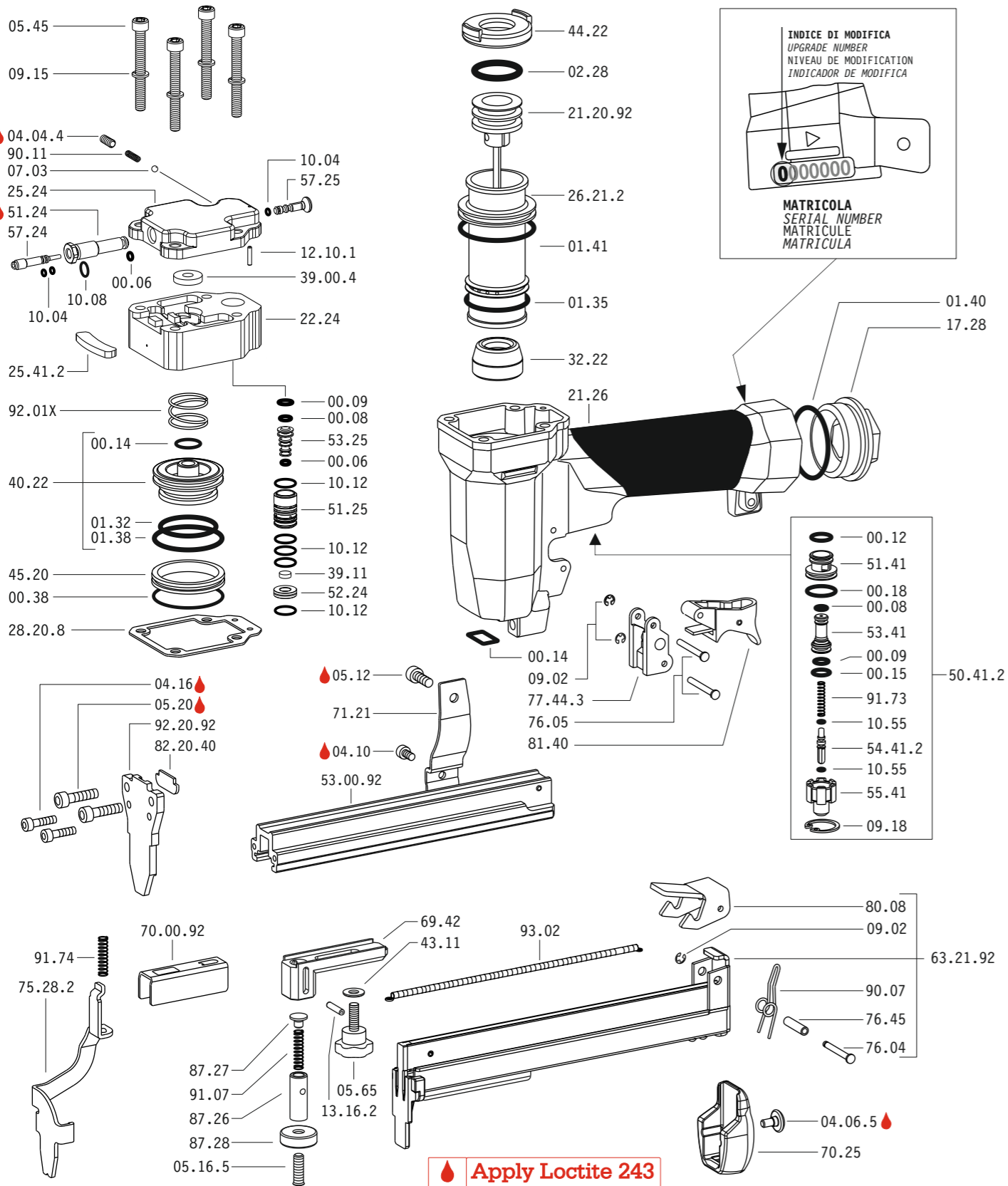

Dotazioni - Equipment - Ausrüstung - Équipements - Equipamiento - Παρεχόμενα
Equipamento - Uitrusting - Udstyr

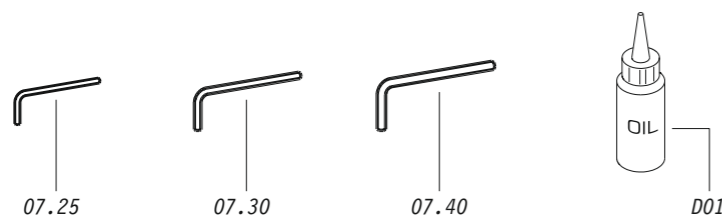

92.25 VD

cod. 12272810

Parti di ricambio - Spare parts - Ersatzteile - Pièces de rechange - Piezas de repuesto
Ανταλλακτικά - Partes sobresselentes - Tabel te raadplegen - Reservedele

Cod.	Descrizione	Description
00.06	O-Ring	O-Ring
00.08	O-Ring	O-Ring
00.09	O-Ring	O-Ring
00.12	O-Ring	O-Ring
00.14	O-Ring	O-Ring
00.15	O-Ring	O-Ring
00.18	O-Ring	O-Ring
00.38	O-Ring	O-Ring
01.32	O-Ring	O-Ring
01.35	O-Ring	O-Ring
01.38	O-Ring	O-Ring
01.40	O-Ring	O-Ring
01.41	O-Ring	O-Ring
02.28	O-Ring	O-Ring
04.04.4	Vite	Screw
04.06.5	Vite	Screw
04.10	Vite	Screw
04.16	Vite	Screw
05.12	Vite	Screw
05.16.5	Vite	Screw
05.20	Vite	Screw
05.45	Vite	Screw
05.65	Vite	Screw
07.03	Sfera	Ball
07.25	Chiave esagonale	Hex. bar wrench
07.30	Chiave esagonale	Hex. bar wrench
07.40	Chiave esagonale	Hex. bar wrench
09.02	Anello elastico	Elastic ring
09.15	Rondella	Washer
09.18	Anello elastico	Elastic ring
10.04	O-Ring	O-Ring
10.08	O-Ring	O-Ring
10.12	O-Ring	O-Ring
10.55	O-Ring	O-Ring
12.10.1	O-Ring	O-Ring
13.16.2	Spina	Pin
17.28	Tappo	Inlet cap
21.26	Corpo	Body
22.24	Testa	Head
25.24	Deflettore	Exhaust deflector
25.41.2	Silenziatore	Silencer
26.21.2	Cilindro	Cylinder
28.20.8	Guarnizione testa	Head gasket
32.22	Ammortizzatore	Bumper
39.00.4	Guarnizione scarico	Exhaust seal
39.11	Guarnizione	Seal
40.22	Valvola completa	Valve ass'y
43.11	Rondella	Washer
44.22	Guarnizione	Gasket
45.20	Anello valvola	Ring
50.41.2	Pulsante completo	Trigger valve ass'y
51.24	Boccola regolatore	Regulator valve housing
51.25	Cilindro servovalvola	Valve cylinder
51.41	Boccola pulsante	Trigger valve housing
52.24	Tappo	Stopper
53.25	Pistone servovalvola	Valve piston
53.41	Pistone servovalvola	Valve piston
54.41.2	Pulsante	Trigger valve
55.41	Raccordo pulsante	Bush
57.24	Regolatore	Regulator
57.25	Interruttore	Switch
69.42	Distanziatore	Spacer
70.25	Protezione	Guard
71.21	Reggicaricatore	Support
75.28.2	Sicura	Safety
76.04	Perno	Pin72.21
76.05	Perno	Pin
76.45	Perno molla	Pin
77.44.3	Guida sicura	Safety guide
80.08	Grilletto chiusura	Trigger
81.40	Grilletto comando	Trigger
87.26	Perno	Pin
87.27	Portamolla	Supporter
87.28	Cuscinetto	Bearing
90.11	Molla	Spring
90.07	Molla	Spring
91.07	Molla	Spring
91.73	Molla	Spring
91.74	Molla	Spring
92.01X	Molla	Spring
93.02	Molla	Spring
21.20.92	Battente	Driver
53.00.92	Caricatore	Magazine
63.21.92	Carrello	Slider
70.00.92	Spingipunto	Pusher
82.20.40	Controtestina	Nose
92.20.92	Testina	Nose plate
D01	Bocchetta olio	Oiler

Guarnizioni - O-Rings - Dichtungen - Joints - Kit O-Rings - Αρσπυγκία - Kit O-Rings - Pakninger

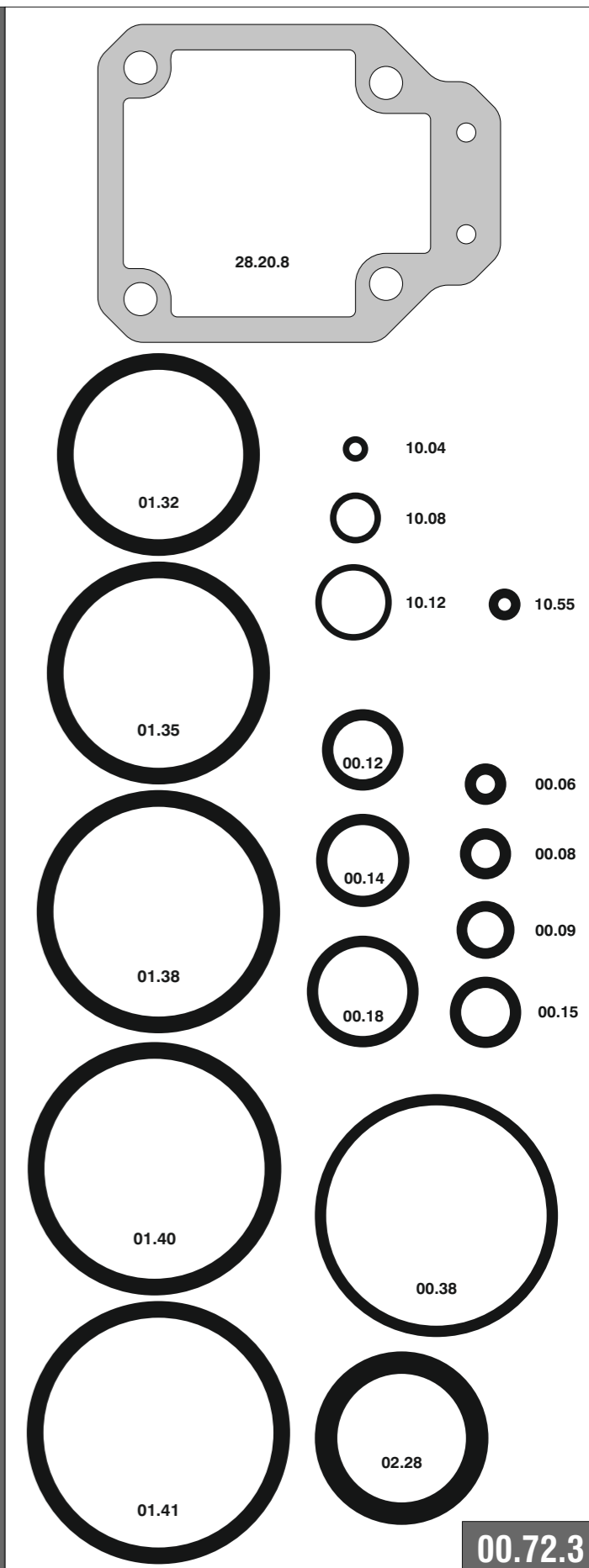

12272810_9225VD_2_191218_IV

92.25 VD

cod. 12272810

Indice di modifica
Upgrade number

2

2432672

Funzionamento - Operating mode

Automatica Auto-fire

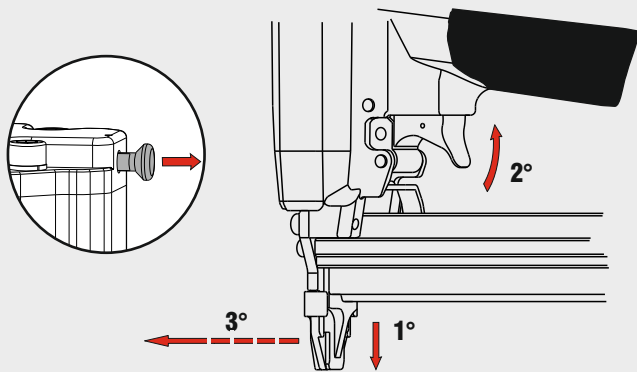

Regolazione della velocità Speed adjustment

Max 1000 Cpm

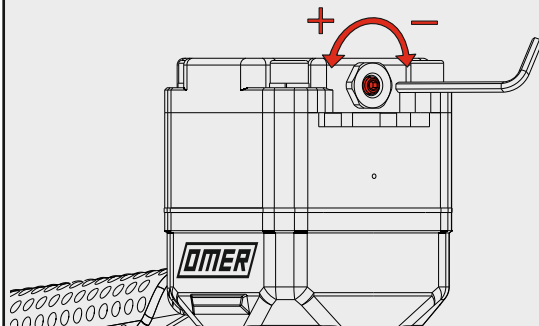

Colpo martello Bump fire

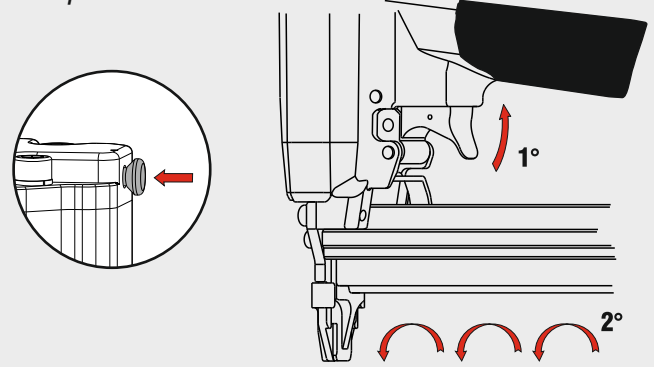

Oppure - Or

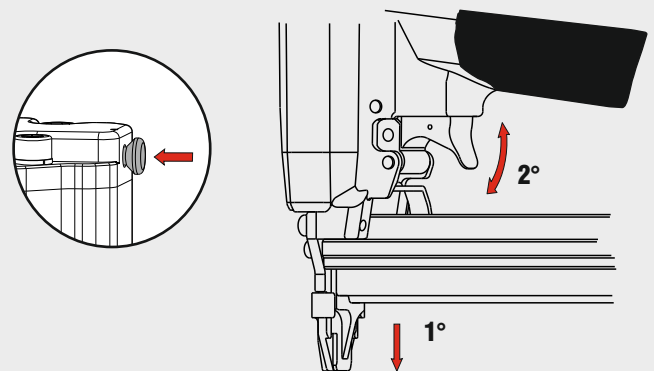

Utilizzo senza distanziale Operating without spacer

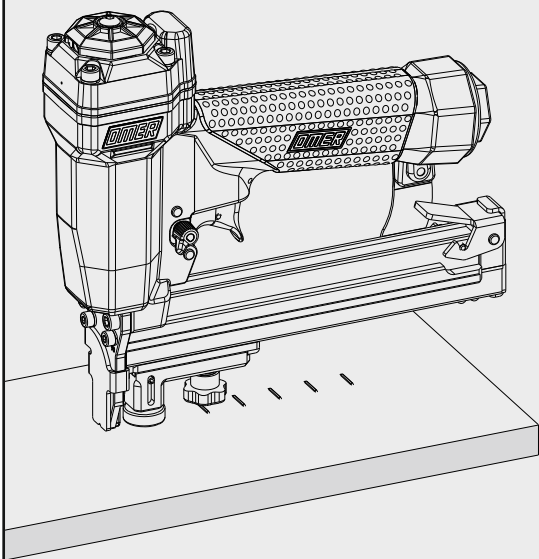

Utilizzo con distanziale Operating with spacer

