

Caricamento - Loading

Caricamento da sotto Bottom load magazine

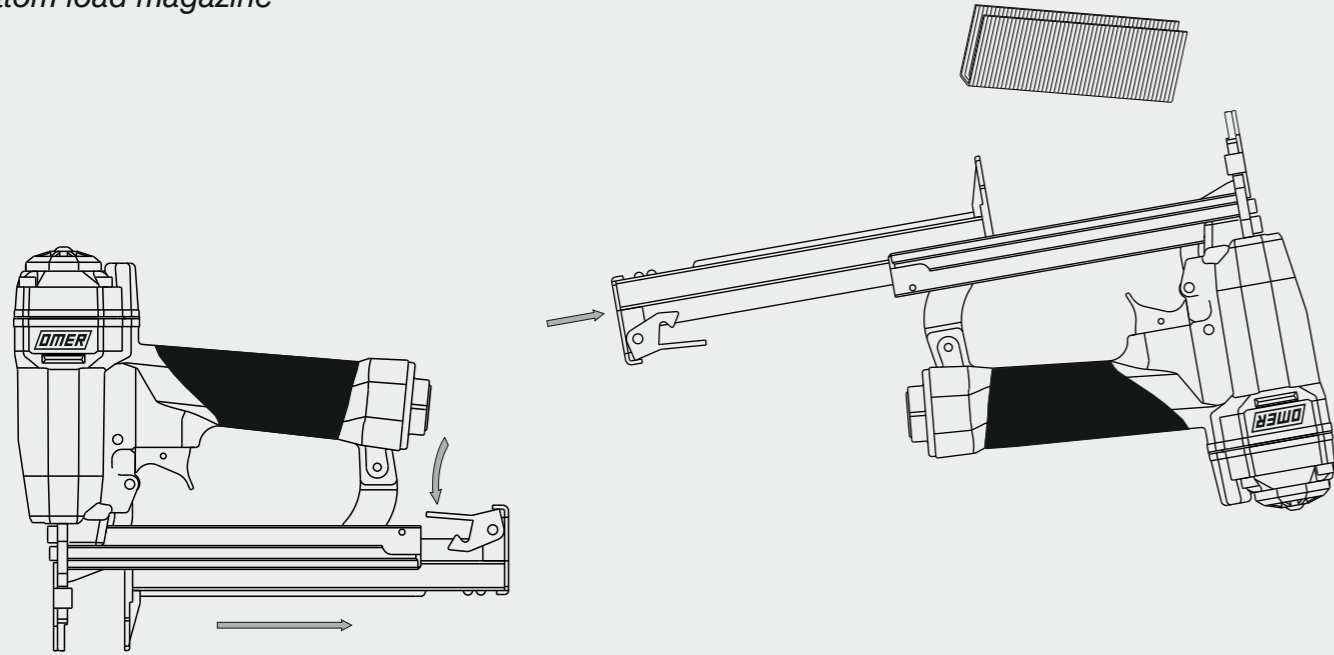

-Premere il grilletto chiusura

Press the magazine latch

-Arretrare il carrello

Pull the slider

-Capovolgere la graffatrice

Turn the tool up side down

-Inserire le graffe

Load the magazine with staples

-Chiudere il carrello

Shut the slider



Non azionare MAI il grilletto comando o la sicura a contatto durante il caricamento della graffatrice.
NEVER pull the trigger or the contact safety while loading magazine.

Caratteristiche - Features

Sparo sequenziale singolo - Single sequential actuation



Manuale d'uso, manutenzione e parti di ricambio

Use, maintenance and spare parts manual

Gebrauchsanweisung, Instandhaltungsrichtlinien und Ersatzteile

Manuel d'utilisation, entretien et pièces de rechange

Manual de uso, mantenimiento y repuestos

Εγχειρίδιο χρήσης, συντήρησης και ανταλλακτικών

Manual de utilização, manutenção e partes sobresselentes

Handleiding voor gebruik, onderhoud en reservedeelslijst

Brugsanvisning, vedligeholdelse og reservedeelsliste

Parte 2

Part 2

Teil 2

Partie 2

Part 2

2° Μερὸς

Parte 2

Deel 2

Del 2



SG44.25 SQ

cod. 1227800SQ

1227800A_SG4425A_2 010716 IV

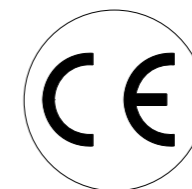

Dati tecnici Technical data Technische daten	Données techniques Datos tècnicos Τεχνικά χαρακτηριστικά	Dados tècnicos Technischegegevens Teknische data
--	--	--

Misure impieghiabili mm Usable lengths mm Gebrauchliche Längen mm	Mesures utilisable mm Medidas que se pueden emplear mm Διαστάσεις σε μμ	Medidas que se podem utilizar mm Te gebruiken engtes in mm Brugbare laengder i mm	9 ÷ 25
Capacità caricatore n° punti Magazine capacity No. of fasteners Magazinkapazität Nägel	Capacité chargeur n° de points Capacidad cargador n° puntos Δυνατότητα γεμιστέρα, σπώνδερες	Capacitade carregador n° pontos Capaciteit magazijn in aantal spijkers Kapacitet af magasin antal klemme	105
Pressione d'esercizio Working pressure Betriebsdruck	Pression de fonctionnement Presión de trabajo Πίεση λειτουργίας ατμ.	Pressao de trabalho Werkdruk Arbejds tryk bar	5 ÷ 7,5 bar 70 ÷ 105 psi
Consumo aria litri/colpo Air consumption litres/shot Luftverbrauch Liter/Schlag	Consommation air litre/coup Consumo aire-litros/golpe Καταναλοση αερα λ/ξτῶπημα	Consumo ar litro/golpe Luchtverbruik liter/schot Luftforbrug liter/skud	0,31
Peso kg Weight kg Gewicht kg	Poids kg Peso kg Βαρος κγ	Peso kg Gewicht in kg Vaegt kg	1,15
Dimensioni (AxBxH) mm Dimensions mm Größe mm	Dimension mm Dimensiones mm Δυνατότητα γεμιστέρα, σπώνδερες	Dimencoes mm Afmetingen in mm Dimensioner mm	226x50x211

EN 12549 :1999 ISO 11201 :1995			
Pressione sonora in pos. operatore Sound pressure at the workstation Lärmintensität am Arbeitsplatz	Pression acoustique près de l'opérateur Presión sonora en posición encargado Ακουστική πίεση στη θέση χειριστού	Intensidade sonora perto do operador Geluidssterkte op de werkplek Lydstyrke på operatorposten	$L_{pA,1s}$ (Rif. 20μPa) 80,1 dB(A)

EN 12549 :1999 ISO 3744 :1994			
Potenza sonora emessa Emitted sound power Ausgestrahlte Lärmintensität	Puissance acoustique émise Potencia sonora emitida Ακουστική ισχυ	Potência sonora emitida Uitgestraalde geluidssterkte Udsendt lydstryke	$L_{WA,1s}$ (Rif. 1pW) 86,9 dB(A)

EN 28662 :1992 ISO 5349 :1986 ISO 8662 -11			
Valore medio ponderato di vibrazione sull'impugnatura Weighted mean value of vibration on the grip Mitteler Vibrationswert, am Griff Gemessen	Valeur moyenne pondérée de vibration mesurée sur la poignée Valor medio ponderado de vibracion medida en la empunadura Μεσος ορος μετρησης κραδασμων στη χειρολαβη	Valor medio ponderado de vibracao medida no punho Gewogen gemiddelde vibratiewaarde Middelvaardi af vibrationer pa handtaget	<2,5 m/s²

Tipo di punto
Type of fastener
Befestigungselement
Type d'agrafe
Tipo de punto
Τύπος κάρφιου
Tipo de ponto
Type nietjes
Tilspændingstype

SG44

1,00x1,25

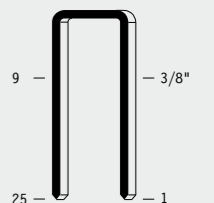

7,8

Gauge: 18
Crown: .387" (3/8")

Parti di ricambio - Spare parts - Ersatzteile - Pièces de rechange - Piezas de repuesto
Ανταλλακτικά - Partes sobresselentes - Tabel te raadplegen - Reservedede

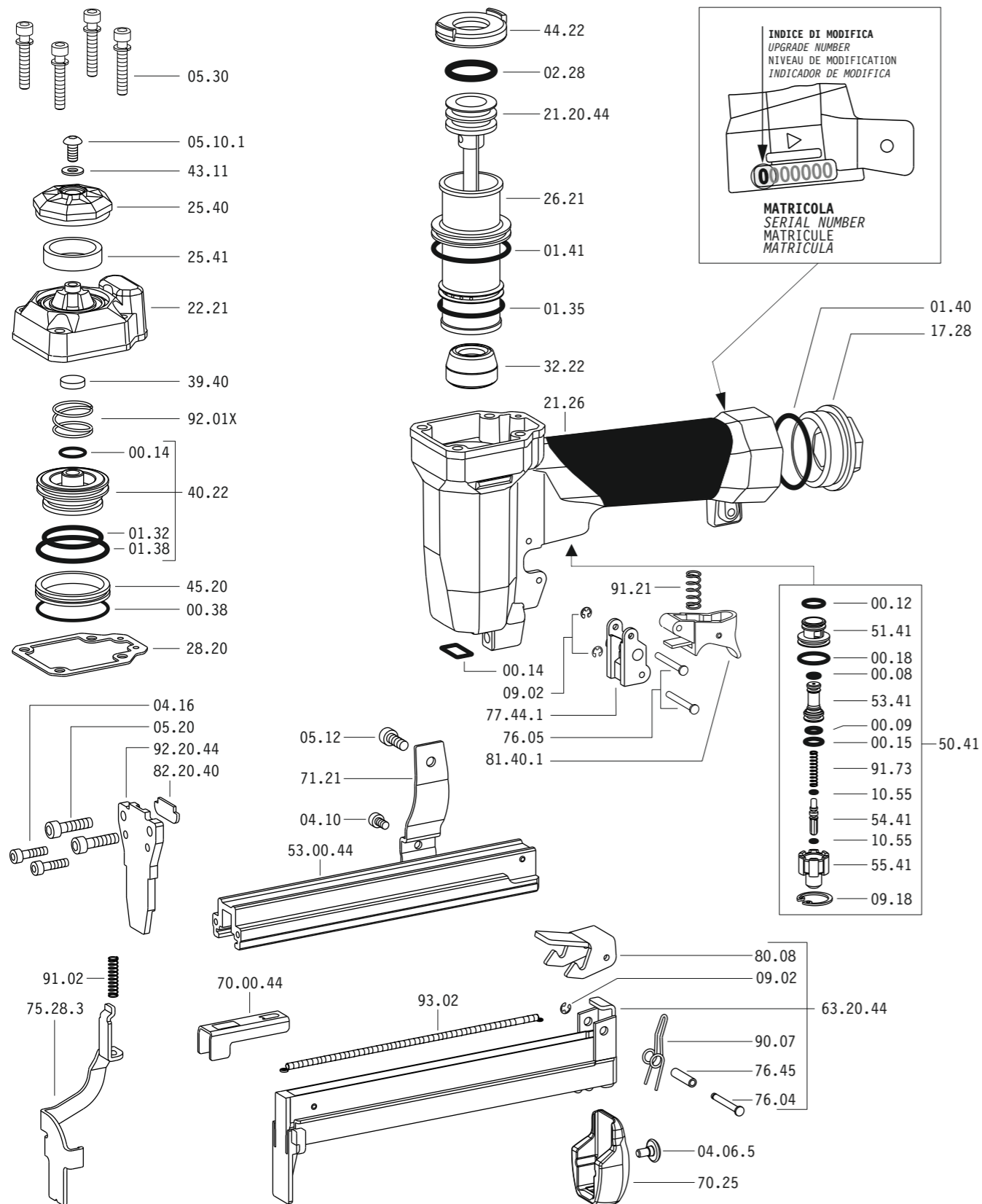

Dotazioni - Equipment - Ausrüstung - Équipements - Equipamiento - Παρεχόμενα
Equipamento - Uitrusting - Udstyr

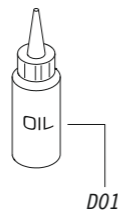

SG44.25 SQ

cod. 1227800SQ

Parti di ricambio - Spare parts - Ersatzteile - Pièces de rechange - Piezas de repuesto
Ανταλλακτικά - Partes sobresselentes - Tabel te raadplegen - Reservedede

Cod.	Descrizione	Description
00.08	O-Ring	O-Ring
00.09	O-Ring	O-Ring
00.12	O-Ring	O-Ring
00.14	O-Ring	O-Ring
00.15	O-Ring	O-Ring
00.18	O-Ring	O-Ring
00.38	O-Ring	O-Ring
01.32	O-Ring	O-Ring
01.35	O-Ring	O-Ring
01.38	O-Ring	O-Ring
01.40	O-Ring	O-Ring
01.41	O-Ring	O-Ring
02.28	O-Ring	O-Ring
04.06.5	Vite	Screw
04.10	Vite	Screw
04.16	Vite	Screw
05.10.1	Vite	Screw
05.12	Vite	Screw
05.20	Vite	Screw
05.30	Vite	Screw
07.30	Chiave esagonale	Hex. bar wrench
07.40	Chiave esagonale	Hex. bar wrench
09.02	Anello elastico	Elastic ring
09.18	Anello elastico	Elastic ring
10.55	O-Ring	O-Ring
17.28	Tappo	Inlet cap
21.26	Corpo	Body
22.21	Testa	Head
25.40	Deflettore	Exhaust deflector
25.41	Silenziatore	Silencer
26.21	Cilindro	Cylinder
28.20	Guarnizione testa	Head gasket
32.22	Ammortizzatore	Bumper
39.40	Guarnizione scarico	Exhaust seal
40.22	Valvola completa	Valve ass'y
43.11	Rondella	Washer
44.22	Guarnizione	Gasket
45.20	Anello valvola	Ring
50.41	Pulsante completo	Trigger valve ass'y
51.41	Boccola pulsante	Trigger valve housing
53.41	Pistone servovalvola	Valve piston
54.41	Pulsante	Trigger valve
55.41	Raccordo pulsante	Bush
70.25	Protezione	Guard
71.21	Reggicaricatore	Support
75.28.3	Sicura	Safety
76.04	Perno	Pin
76.05	Perno	Pin
76.45	Perno molla	Pin
77.44.1	Guida sicura	Safety guide
80.08	Grilletto chiusura	Trigger
81.40D	Grilletto comando	Trigger
90.07	Molla	Spring
91.02	Molla	Spring
91.21	Molla	Spring
91.73	Molla	Spring
92.01X	Molla	Spring
93.02	Molla	Spring
21.20.44	Battente	Driver
53.00.44	Caricatore	Magazine
63.20.44	Carrello	Slider
70.00.44	Spingipunto	Pusher
82.20.40	Controtestina	Nose
92.20.44	Testina	Nose plate
D01	Bocchetta olio	Oiler

Guarnizioni - O-Rings - Joints - Kit O-Rings - Λαστιχάκια - Kit O-Rings - O-ringen - Pakninger

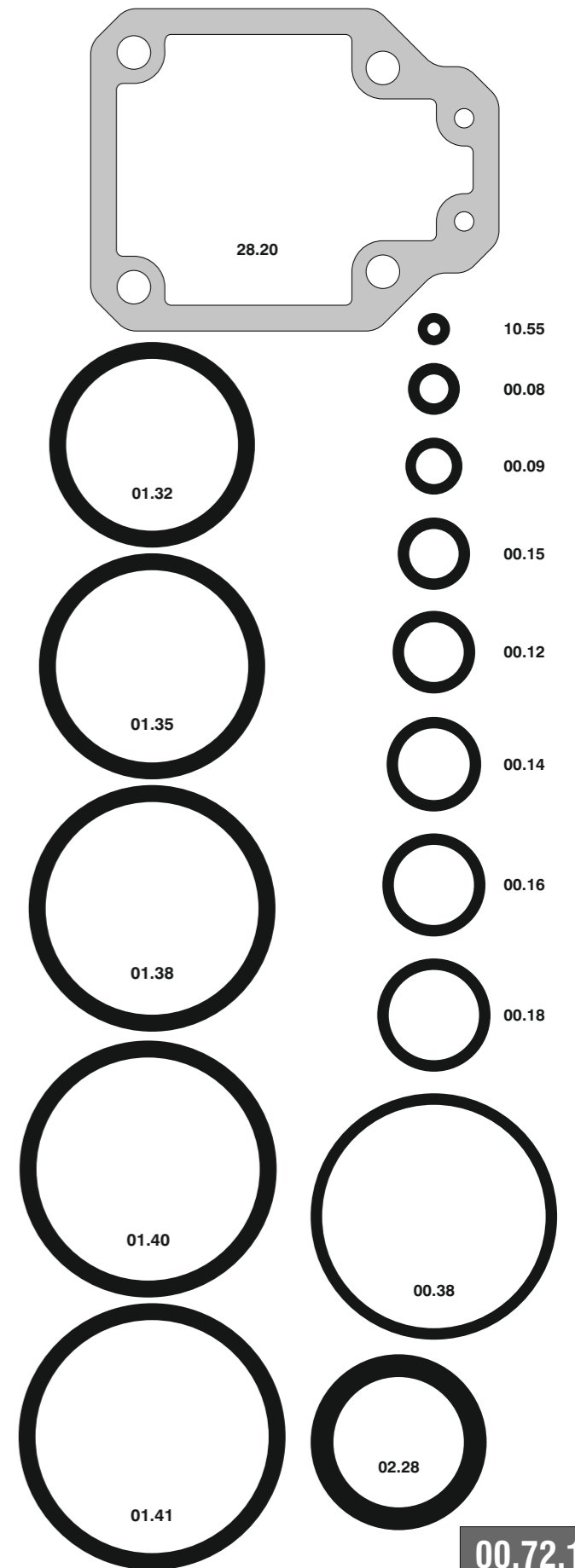

1227800A_SG4425A_2_010716_IV

SG44.25 SQ

cod. 1227800SQ

Indice di modifica
Upgrade number

2

2516830