

## Caricamento - Loading

### Caricamento da sotto Bottom load magazine

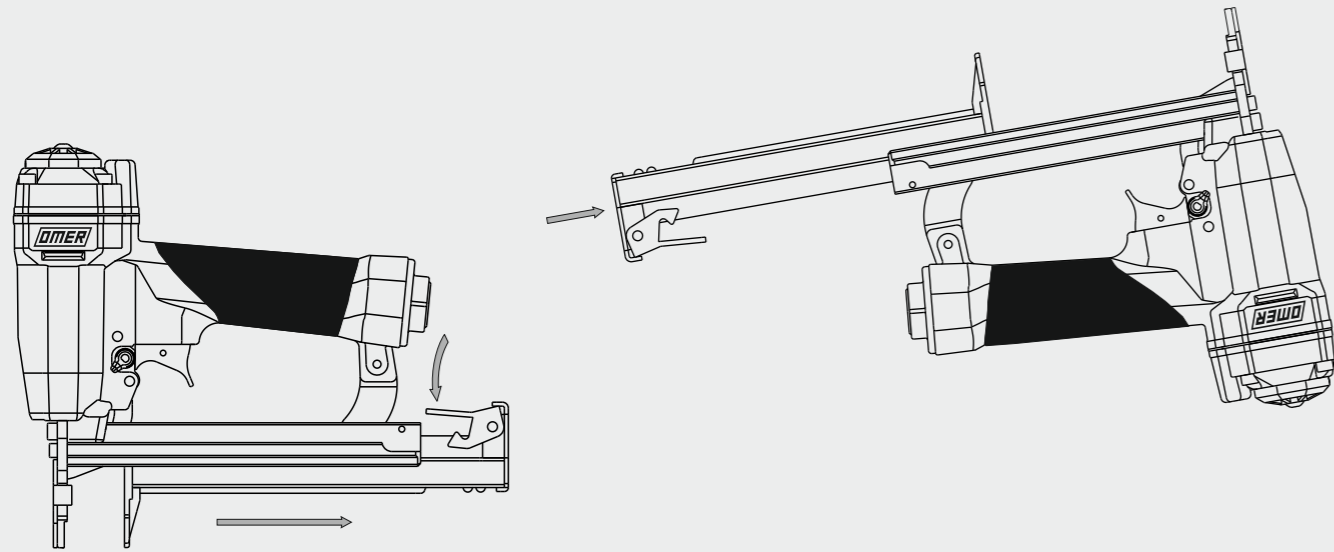

- Premere il grilletto chiusura  
Press the magazine latch
- Arretrare il carrello  
Pull the slider
- Capovolgere la graffatrice  
Turn the tool up side down
- Inserire le graffe  
Load the magazine with staples
- Chiudere il carrello  
Shut the slider



**Non azionare MAI il grilletto comando o la sicura a contatto durante il caricamento della graffatrice.  
NEVER pull the trigger or the contact safety while loading magazine.**



**Manuale d'uso, manutenzione e parti di ricambio**  
**Use, maintenance and spare parts manual**  
**Gebrauchsanweisung, Instandhaltungsrichtlinien und Ersatzteile**  
**Manuel d'utilisation, entretien et pièces de rechange**  
**Manual de uso, mantenimiento y repuestos**  
Εγχειρίδιο χρήσης, συντήρησης και ανταλλακτικών  
**Manual de utilização, manutenção e partes sobresselentes**  
**Handleiding voor gebruik, onderhoud en reservedelslste**  
**Brugsanvisning, vedligeholdelse og reservedelslste**

**Parte 2**  
**Part 2**  
**Teil 2**  
**Partie 2**  
**Part 2**  
2° Μερὸς  
**Parte 2**  
**Deel 2**  
**Del 2**



# SG44.25

cod. 1227800

1227800\_SG4425\_2 280515 IV

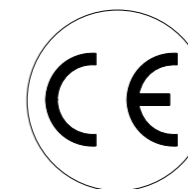

Dati tecnici Technical data Technische daten	Données techniques Datos tècnicos Τεχνικά χαρακτηριστικά	Dados tècnicos Technischegegevens Teknische data
--	--	--

<b>Misure impiegabili mm</b> Usable lengths mm Gebrauchliche Längen mm	Mesures utilisable mm Medidas que se pueden emplear mm Διαστάσεις σε μμ	Medidas que se podem utilizar mm Te gebruiken engtes in mm Brugbare laengder i mm	<b>9÷25</b>
<b>Capacità caricatore n° punti</b> Magazine capacity No. of fasteners Magazinkapazität Nägel	Capacité chargeur n° de points Capacidad cargador n° puntos Δυνατότητα γεμιστέρα, σπινδότερες	Capacidade carregador n° pontos Capaciteit magazijn in aantal spijkers Kapacitet af magasin antal klemme	<b>100</b>
<b>Pressione d'esercizio</b> Working pressure Betriebsdruck	Pression de fonctionnement Presión de trabajo Πίεση λειτουργίας ατμ.	Pressao de trabalho Werkdruk Arbejds tryk bar	<b>5÷7 bar 70÷100 psi</b>
<b>Consumo aria litri/colpo</b> Air consumption litres/shot Luftverbrauch Liter/Schlag	Consommation air litre/coup Consumo aire-litros/golpe Καταναλοση αερα λ/ξετπημα	Consumo ar litro/golpe Luchtverbruik liter/schot Luftforbrug liter/skud	<b>0,31</b>
<b>Peso kg</b> Weight kg Gewicht kg	Poids kg Peso kg Βαρος κγ	Peso kg Gewicht in kg Vaegt kg	<b>1,10</b>
<b>Dimensioni (AxBxH) mm</b> Dimensions mm Große mm	Dimension mm Dimensiones mm Δυνατότητα γεμιστέρα, σπινδότερες	Dimencoes mm Afmetingen in mm Dimensioner mm	<b>226x50x211</b>

EN 12549 :1999	ISO 11201 :1995		
<b>Pressione sonora in pos. operatore</b> Sound pressure at the workstation Lärmintensität am Arbeitsplatz	Pression acoustique près de l'opérateur Presión sonora en posición encargado Ακουστική πίεση στη θέση χειριστου	Intensidade sonora perto do operador Geluidssterkte op de werkplek Lydstyrke på operatorposten	$L_{pA,1s}$ (Rif. 20μPa) <b>80,1 dB(A)</b>

EN 12549 :1999	ISO 3744 :1994		
<b>Potenza sonora emessa</b> Emitted sound power Ausgestrahlte Lärmintensität	Puissance acoustique émise Potencia sonora emitida Ακουστική ισχυ	Potência sonora emitida Uitgestraalde geluidssterkte Udsendt lydstrykke	$L_{WA,1s}$ (Rif. 1pW) <b>86,9 dB(A)</b>

EN 28662 :1992	ISO 5349 :1986	ISO 8662 -11	
<b>Valore medio ponderato di vibrazione sull'impugnatura</b> Weighted mean value of vibration on the grip Mitteler Vibrationswert, am Griff Gemessen	Valeur moyenne pondérée de vibration mesurée sur la poignée Valor medio ponderado de vibracion medida en la empunadura Μεσοσ ορος μετρησης κραδασιων στη χειρολαβη	Valor medio ponderado de vibracao medida no punho Gewogen gemiddelde vibratiewaarde Middelvaerdi af vibrationer pa handtaget	<b>&lt;2,5 m/s<sup>2</sup></b>

**Tipo di punto**  
Type of fastener  
Befestigungselement  
Type d'agrafe  
Tipo de punto  
Τυπος κάρφιου  
Tipo de ponto  
Type nietjes  
Tilspændingstype

**SG44**

1,00x1,25

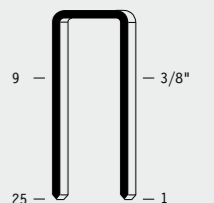

7,8

Gauge: 18  
Crown: .387" (3/8")

## Caratteristiche - Features

### Colpo singolo Single shot

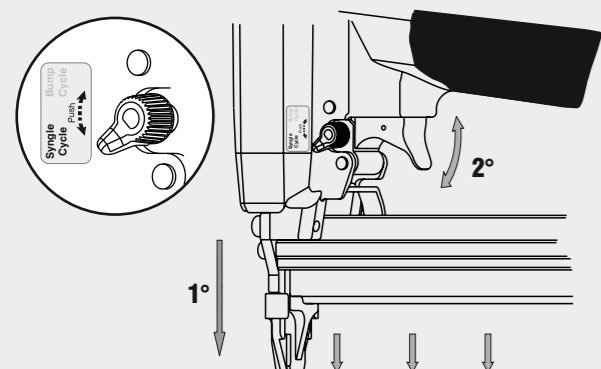

### Colpo martello Bump fire

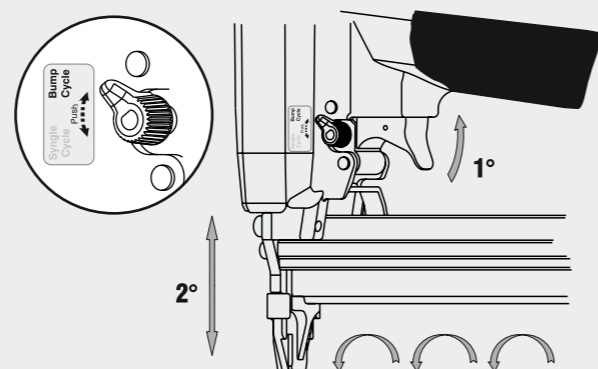

Parti di ricambio - Spare parts - Ersatzteile - Pièces de rechange - Piezas de repuesto  
Ανταλλακτικά - Partes sobresselentes - Tabel te raadplegen - Reservedede

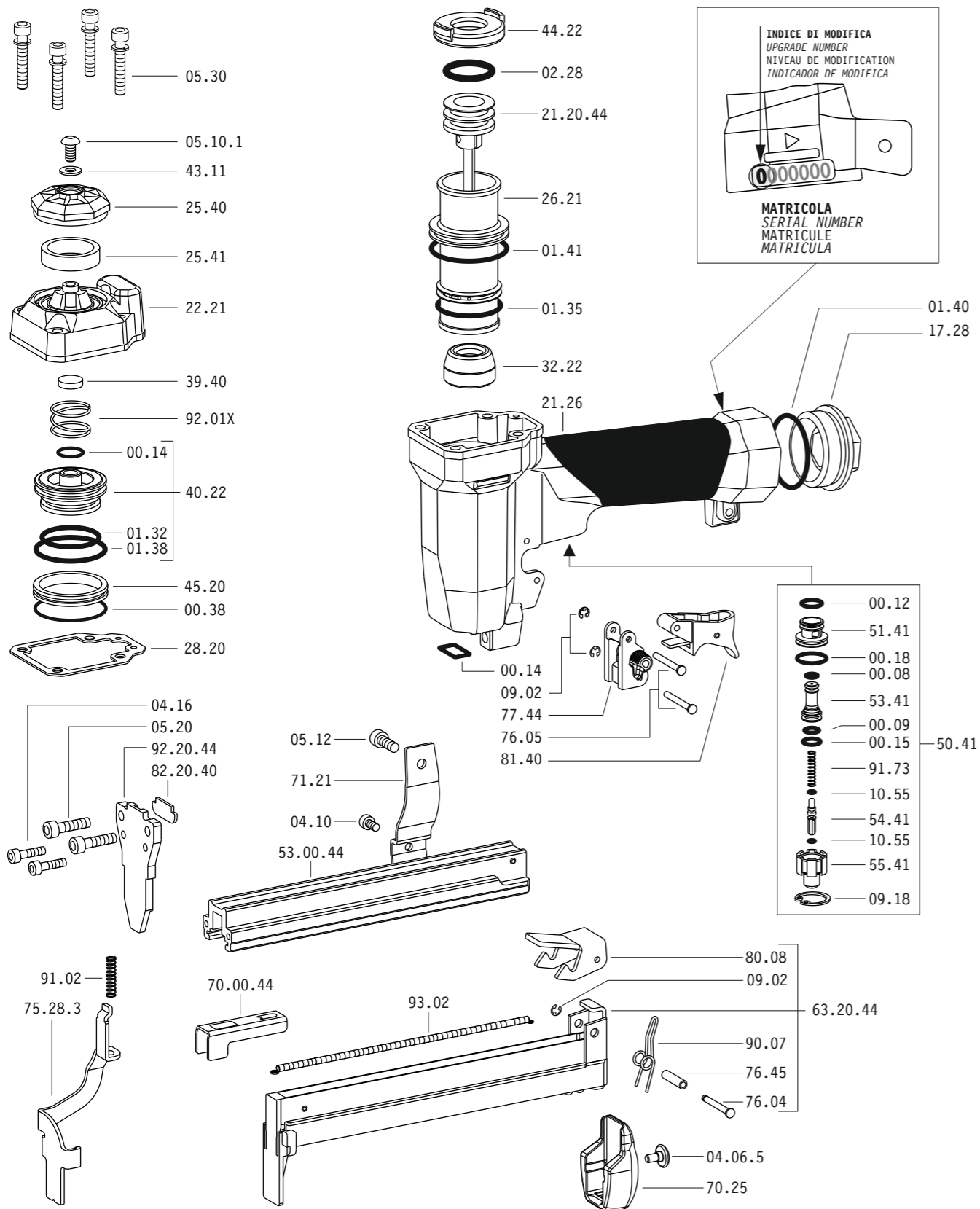

Dotazioni - Equipment - Ausrüstung - Équipements - Equipamiento - Παρεχόμενα  
Equipamento - Uitrusting - Udstyr

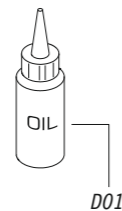

**SG44.25**

cod. 1227800

Parti di ricambio - Spare parts - Ersatzteile - Pièces de rechange - Piezas de repuesto  
Ανταλλακτικά - Partes sobresselentes - Tabel te raadplegen - Reservedede

Cod.	Descrizione	Description
00.08	O-Ring	O-Ring
00.09	O-Ring	O-Ring
00.12	O-Ring	O-Ring
00.14	O-Ring	O-Ring
00.15	O-Ring	O-Ring
00.18	O-Ring	O-Ring
00.38	O-Ring	O-Ring
01.32	O-Ring	O-Ring
01.35	O-Ring	O-Ring
01.38	O-Ring	O-Ring
01.40	O-Ring	O-Ring
01.41	O-Ring	O-Ring
02.28	O-Ring	O-Ring
04.06.5	Vite	Screw
04.10	Vite	Screw
04.16	Vite	Screw
05.10.1	Vite	Screw
05.12	Vite	Screw
05.20	Vite	Screw
05.30	Vite	Screw
07.30	Chiave esagonale	Hex. bar wrench
07.40	Chiave esagonale	Hex. bar wrench
09.02	Anello elastico	Elastic ring
09.18	Anello elastico	Elastic ring
10.55	O-Ring	O-Ring
17.28	Tappo	Inlet cap
21.26	Corpo	Body
22.21	Testa	Head
25.40	Deflettore	Exhaust deflector
25.41	Silenziatore	Silencer
26.21	Cilindro	Cylinder
28.20	Guarnizione testa	Head gasket
32.22	Ammortizzatore	Bumper
39.40	Guarnizione scarico	Exhaust seal
40.22	Valvola completa	Valve ass'y
43.11	Rondella	Washer
44.22	Guarnizione	Gasket
45.20	Anello valvola	Ring
50.41	Pulsante completo	Trigger valve ass'y
51.41	Boccola pulsante	Trigger valve housing
53.41	Pistone servovalvola	Valve piston
54.41	Pulsante	Trigger valve
55.41	Raccordo pulsante	Bush
70.25	Protezione	Guard
71.21	Reggicaricatore	Support
75.28.3	Sicura	Safety
76.04	Perno	Pin
76.05	Perno	Pin
76.45	Perno molla	Pin
77.44	Guida sicura	Safety guide
80.08	Grilletto chiusura	Trigger
81.40	Grilletto comando	Trigger
90.07	Molla	Spring
91.02	Molla	Spring
91.73	Molla	Spring
92.01X	Molla	Spring
93.02	Molla	Spring
21.20.44	Battente	Driver
53.00.44	Caricatore	Magazine
63.20.44	Carrello	Slider
70.00.44	Spingipunto	Pusher
82.20.40	Controtestina	Nose
92.20.44	Testina	Nose plate
D01	Boccetta olio	Oiler

Guarnizioni - O-Rings - Dichtungen - Joints - Kit O-Rings - Ασπινγκια - Kit O-Rings - Pakninger

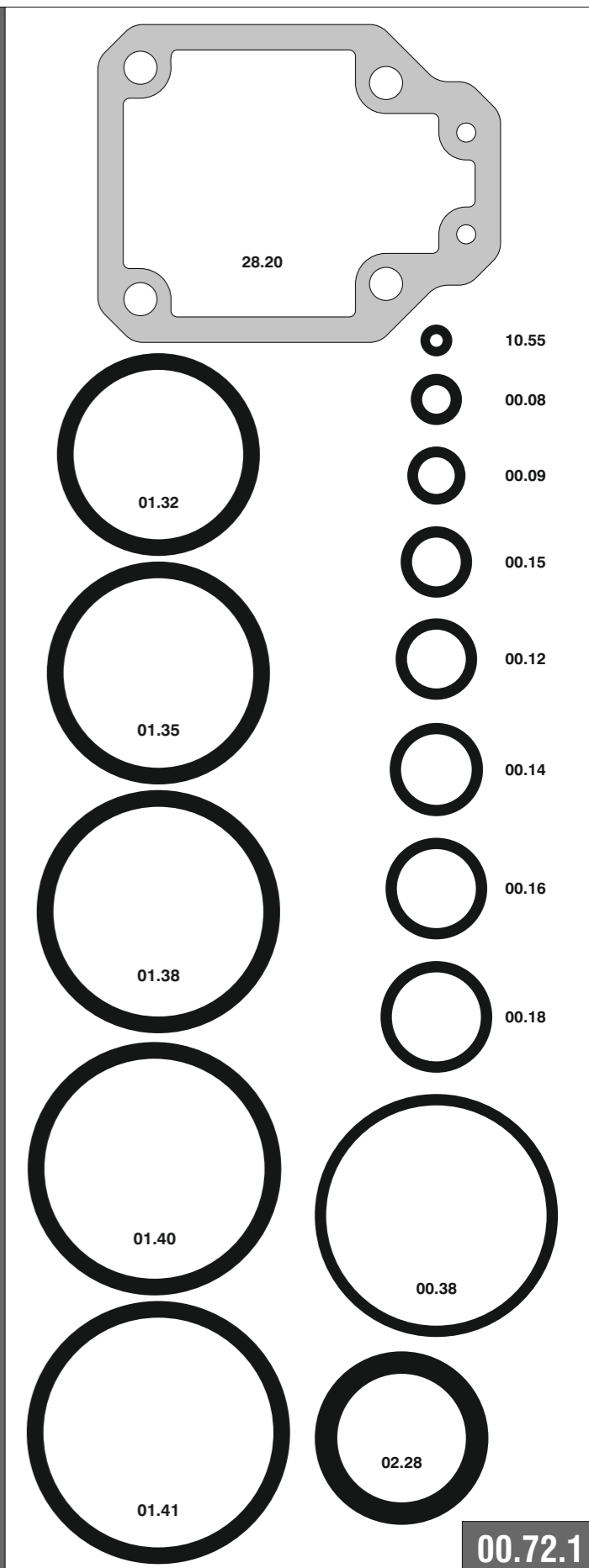

1227800\_SG4425\_2\_280515\_IV

**SG44.25**

cod. 1227800

Indice di modifica  
Upgrade number

**2**

2286738