

Funzionamento e Collegamento - Functioning and Connection

Funziamento: Functioning:

Azionare sia la sicura appoggiandoci il materiale da fissare sia la valvola comando
Actuate the safety by pressing the material to be fastened and the command valve

Collegamento: Connection:

Valvola 3/2 NC
Valve 3/2 NC

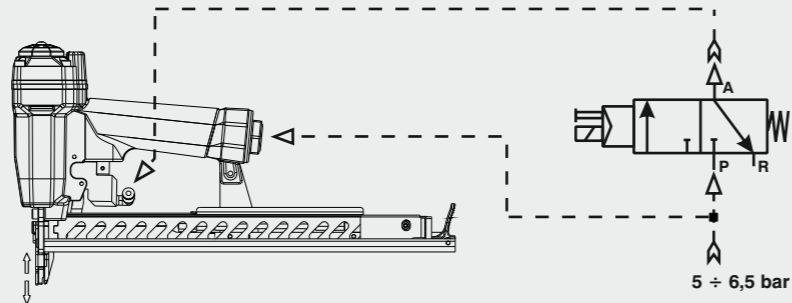

Caricamento - Loading

1 - Arretrare lo Spingipunto e agganciarlo al finecorsa
cio farà aprire il carter mobile
Pull the pusher backwards and lock it at the stop position
at the rear of the tool, this will open the movable hold down

2 - Inserire le graffe
Load the magazine with Staple

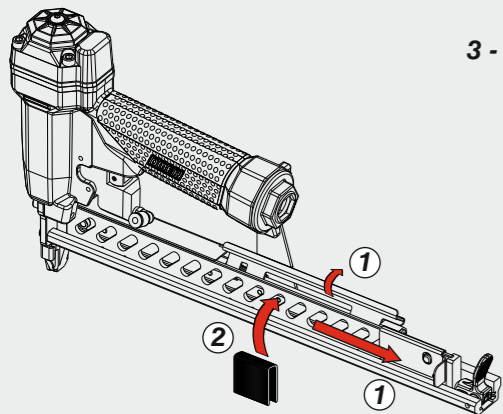

3 - Rilasciare lo Spingipunto
Release the the slider

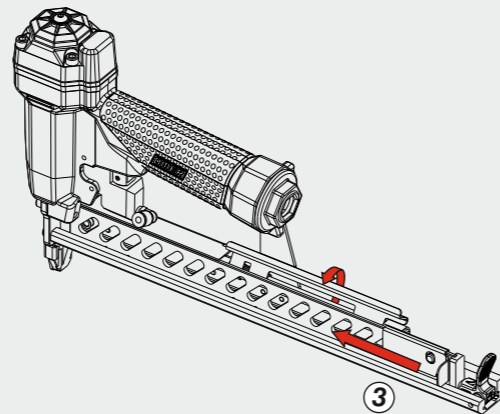

Non azionare MAI la valvola comando o la sicura a contatto durante il caricamento o il disinceppamento della graffatrice.
NEVER actuate the Command Valve or the contact safety while loading or cleaning a jammed stapler.

Disinceppamento macchina - Quick clearance jammed nails

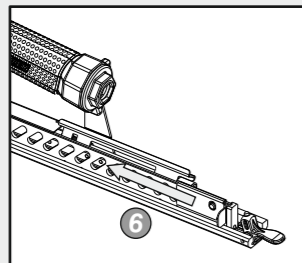
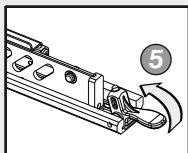
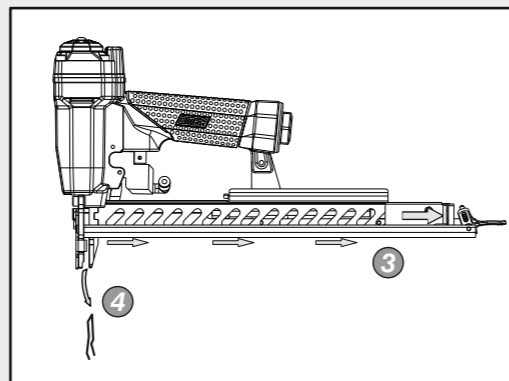
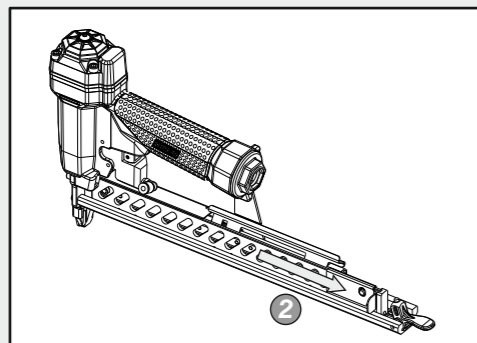
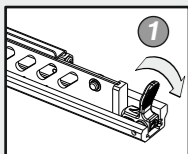

Manuale d'uso, manutenzione e parti di ricambio
Use, maintenance and spare parts manual
Gebrauchsanweisung, Instandhaltungsrichtlinien und Ersatzteile
Manuel d'utilisation, entretien et pièces de rechange
Manual de uso, mantenimiento y repuestos
Εγχειρίδιο χρήσης, συντήρησης και ανταλλακτικών
Manual de utilização, manutenção e partes sobresselentes
Handleiding voor gebruik, onderhoud en reservedeelslste
Brugsanvisning, vedligeholdelse og reservedelslste

Parte 2
Part 2
Teil 2
Partie 2
Part 2
2° Μερους
Parte 2
Deel 2
Del 2



90.25 CLT

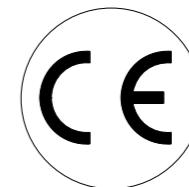

cod. 12370520

12370520_9025CLT_3 120617 IV

Dati tecnici Technical data Technische daten	Données techniques Datos tècnicos Τεχνικά χαρακτηριστικά	Dados tècnicos Technischegegevens Tecniske data
--	--	---

Misure impiegabili mm Usable lengths mm Gebrauchliche Längen mm	Mesures utilisable mm Medidas que se pueden emplear mm Διαστάσεις σε μμ	Medidas que se podem utilizar mm Te gebruiken engtes in mm Brugbare laengder i mm	9÷25
Capacità caricatore n° punti Magazine capacity No. of fasteners Magazinkapazität Nägel	Capacité chargeur n° de points Capacidad cargador n° puntos Δυνατότητα γεμιστέρα, σπινδύτερος	Capacitade carregador n° pontos Capaciteit magazijn in aantal spijkers Kapacitet af magasin antal klemmme	200
Pressione d'esercizio Working pressure Betriebsdruck	Pression de fonctionnement Presión de trabajo Πίεση λειτουργίας ατμ.	Pressao de trabalho Werkdruk Arbejds tryk bar	5 ÷ 7,5 bar 70 ÷ 105 psi
Consumo aria litri/colpo Air consumption litres/shot Luftverbrauch Liter/Schlag	Consommation air litre/coup Consumo aire-litros/golpe Καταναλοση αερα λ/ξτππημα	Consumo ar litro/golpe Luchtverbruik liter/schot Luftforbrug liter/skud	0,31
Peso kg Weight kg Gewicht kg	Poids kg Peso kg Βαρος κγ	Peso kg Gewicht in kg Vaegt kg	1,4
Dimensioni (AxBxH) mm Dimensions mm Größe mm	Dimension mm Dimensiones mm Δυνατότητα γεμιστέρα, σπινδύτερος	Dimencoes mm Afmetingen in mm Dimensioner mm	380x50x211

EN 12549 :1999	ISO 11201 :1995		
Pressione sonora in pos. operatore Sound pressure at the workstation Lärmintensität am Arbeitsplatz	Pression acoustique près de l'opérateur Presión sonora en posición encargado Ακουστική πίεση στη θέση χειριστου	Intensidade sonora perto do operador Geluidssterkte op de werkplek Lydstyrke på operatorposten	$L_{pA,1s}$ (Rif. 20μPa) 80,1 dB(A)

EN 12549 :1999	ISO 3744 :1994		
Potenza sonora emessa Emitted sound power Ausgestrahlte Lärmintensität	Puissance acoustique émise Potencia sonora emitida Ακουστική ισχυ	Potência sonora emitida Uitgestraalde geluidssterkte Udsendt lydstryke	$L_{WA,1s}$ (Rif. 1pW) 86,9 dB(A)

EN 28662 :1992	ISO 5349 :1986	ISO 8662 -11	
Valore medio ponderato di vibrazione sull'impugnatura Weighted mean value of vibration on the grip Mitteler Vibrationswert, am Griff Gemessen	Valeur moyenne pondérée de vibration mesurée sur la poignée Valor medio ponderado de vibracion medida en la empunadura Μεσος ορος μετρησης κραδασμων στη χειρολαβη	Valor medio ponderado de vibracao medida no punho Gewogen gemiddelde vibratiewaarde Middelvaerdi af vibrationer pa handtaget	<2,5 m/s²

Tipo di punto
Type of fastener
Befestigungselement
Type d'agrafe
Tipo de punto
Τυπος κάρφιου
Tipo de ponto
Type nietjes
Tilspændingstype

90

1,00x1,25

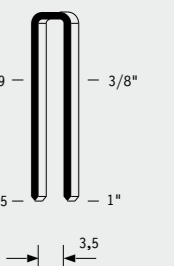

Gauge: 18
Crown: .217" (1/4")

Parti di ricambio - Spare parts - Ersatzteile - Pièces de rechange - Piezas de repuesto
Ανταλλακτικά - Partes sobresselentes - Tabel te raadplegen - Reservedede

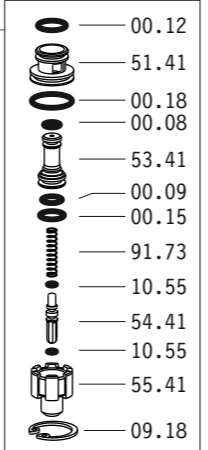
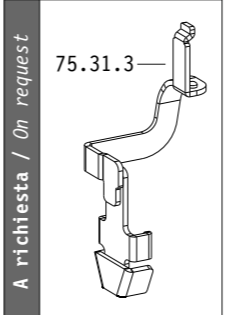
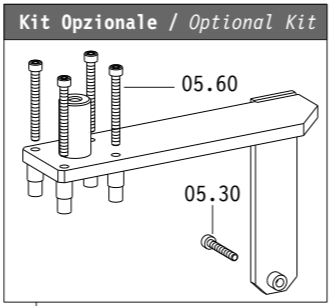
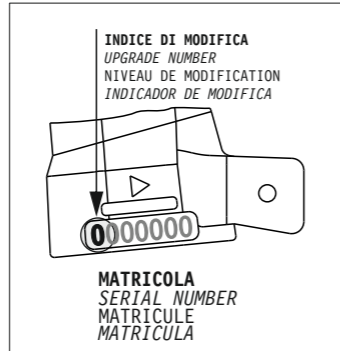
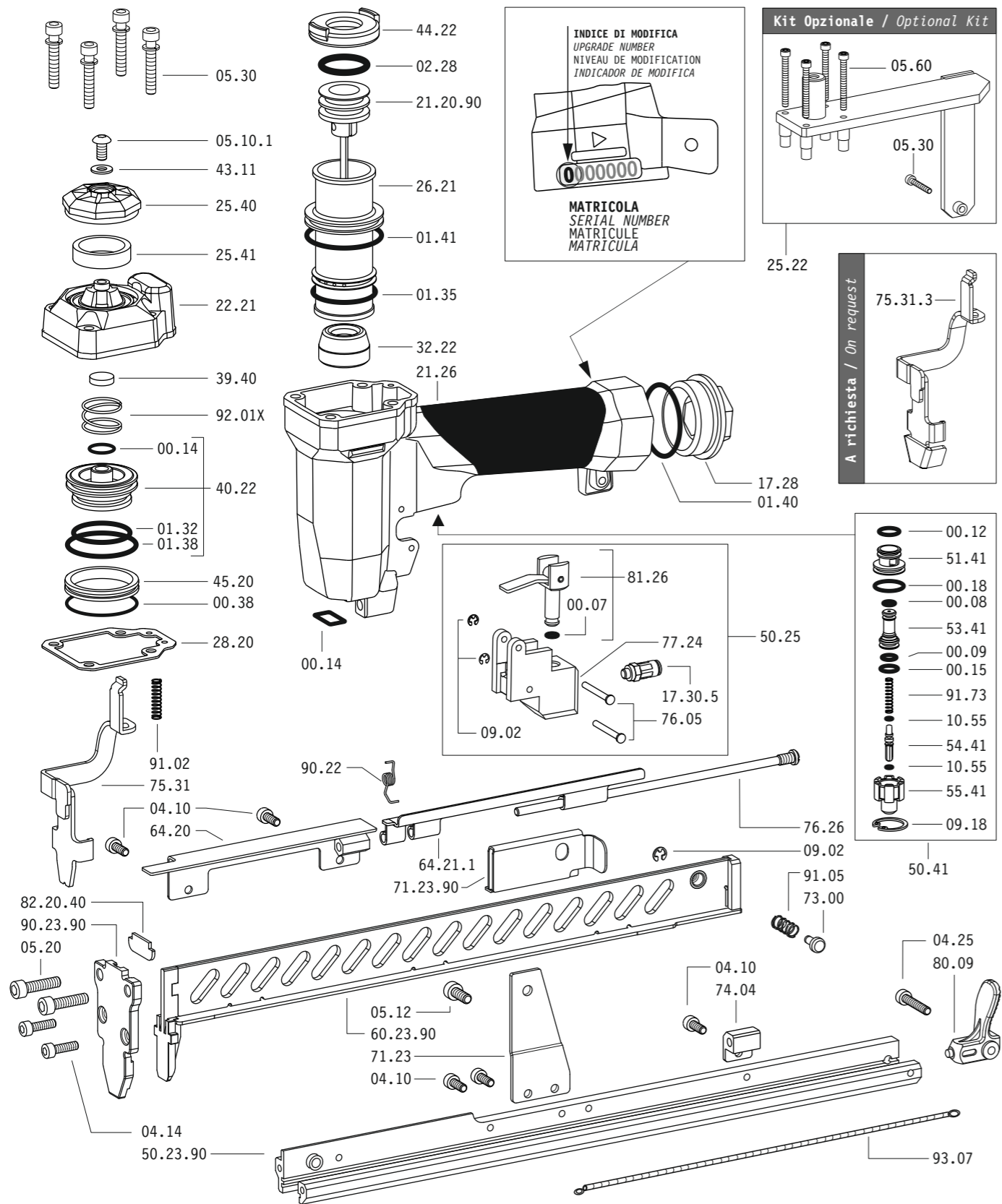

Dotazioni - Equipment - Ausrüstung - Équipements - Equipamiento - Παρεχόμενα
Equipamento - Uitrusting - Udstyr

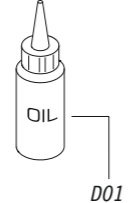

90.25 CLT
cod. 12370520

Parti di ricambio - Spare parts - Ersatzteile - Pièces de rechange - Piezas de repuesto
Ανταλλακτικά - Partes sobresselentes - Tabel te raadplegen - Reservedede

Cod.	Descrizione	Description
00.07	O-Ring	O-Ring
00.08	O-Ring	O-Ring
00.09	O-Ring	O-Ring
00.12	O-Ring	O-Ring
00.14	O-Ring	O-Ring
00.15	O-Ring	O-Ring
00.18	O-Ring	O-Ring
00.38	O-Ring	O-Ring
01.32	O-Ring	O-Ring
01.35	O-Ring	O-Ring
01.38	O-Ring	O-Ring
01.40	O-Ring	O-Ring
01.41	O-Ring	O-Ring
02.28	O-Ring	O-Ring
04.10	Vite	Screw
04.14	Vite	Screw
04.25	Vite	Screw
05.10.1	Vite	Screw
05.12	Vite	Screw
05.20	Vite	Screw
05.30	Vite	Screw
05.60	Vite	Screw
07.30	Chiave esagonale	Hex. bar wrench
07.40	Chiave esagonale	Hex. bar wrench
09.02	Anello elastico	Elastic ring
09.18	Anello elastico	Elastic ring
10.55	O-Ring	O-Ring
17.28	Tappo	Inlet cap
17.30.5	Attacco	Connection
21.26	Corpo	Body
22.21	Testa	Head
25.22	Supporto	Support
25.40	Deflettore	Exhaust deflector
25.41	Silenziatore	Silencer
26.21	Cilindro	Cylinder
28.20	Guarnizione testa	Head gasket
32.22	Ammortizzatore	Bumper
39.40	Guarnizione scarico	Exhaust seal
40.22	Valvola completa	Valve ass'y
43.11	Rondella	Washer
44.22	Guarnizione	Gasket
45.20	Anello valvola	Ring
50.25	Comando a distanza	Remote control
50.41	Pulsante completo	Trigger valve ass'y
51.41	Boccola pulsante	Trigger valve housing
53.41	Pistone servovalvola	Valve piston
54.41	Pulsante	Trigger valve
55.41	Raccordo pulsante	Bush
64.20	Carter	Hold Down
64.21.1	Carter Mobile	Movable Hold Down
71.23	Reggicaricatore	Support
73.00	Perno	Pin
74.04	Staffa	Stirrup
75.31	Sicura	Safety
75.31.3	Sicura	Safety
76.05	Perno	Pin
76.26	Perno carter	Pin
77.24	Guida sicura	Safety guide
80.09	Grilletto chiusura	Trigger
81.26	Pistoncino	Piston
90.22	Molla	Spring
91.02	Molla	Spring
91.05	Molla	Spring
91.73	Molla	Spring
92.01X	Molla	Spring
93.07	Molla	Spring
21.20.90	Battente	Driver
50.23.90	Caricatore	Magazine
60.23.90	Carrello	Slider
71.23.90	Spingipunto	Pusher
82.20.40	Controtestina	Nose
90.23.90	Testina	Nose plate
D01	Boccetta olio	Oiler

Guarnizioni - O-Rings - Dichtungen - Joints - Kit O-Rings - Ασπασμακία - Kit O-Rings - O-ringen - Pakninger

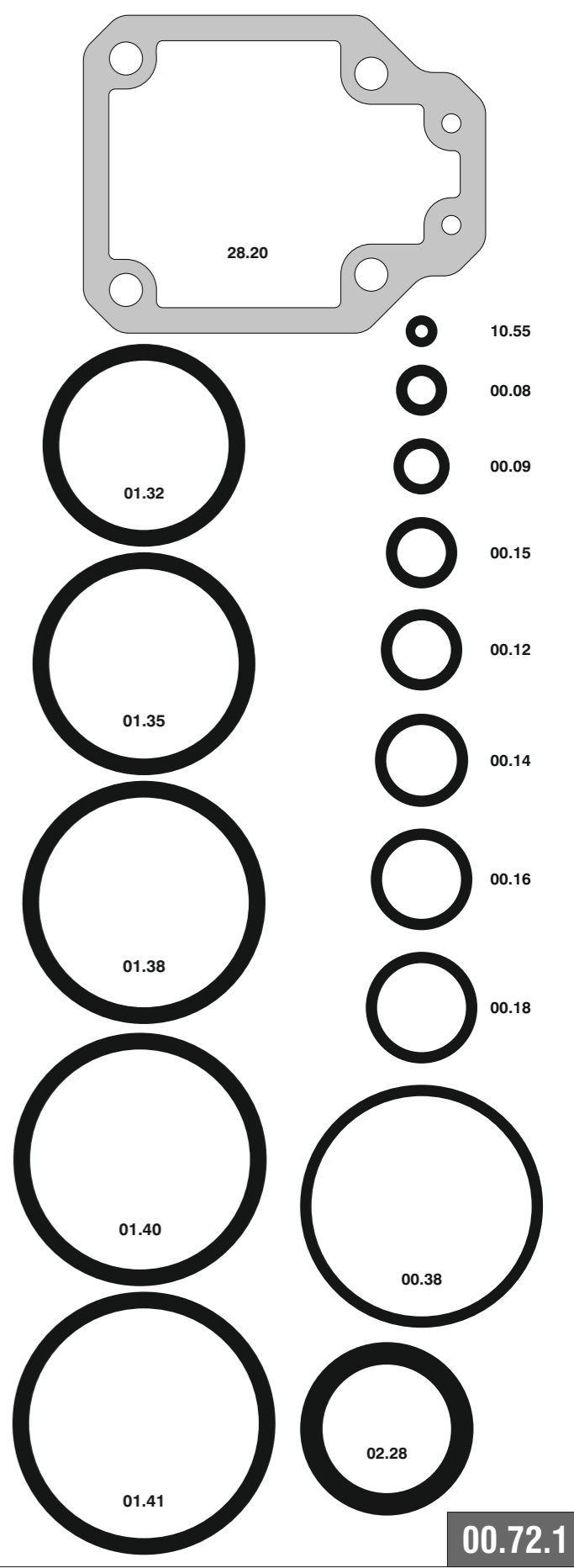

90.25 CLT cod. 12370520

Indice di modifica / Upgrade number

3

3395937

12370520_9025CLT_3 120617 IV