

Caricamento - Loading

Caricamento da sotto Bottom load magazine

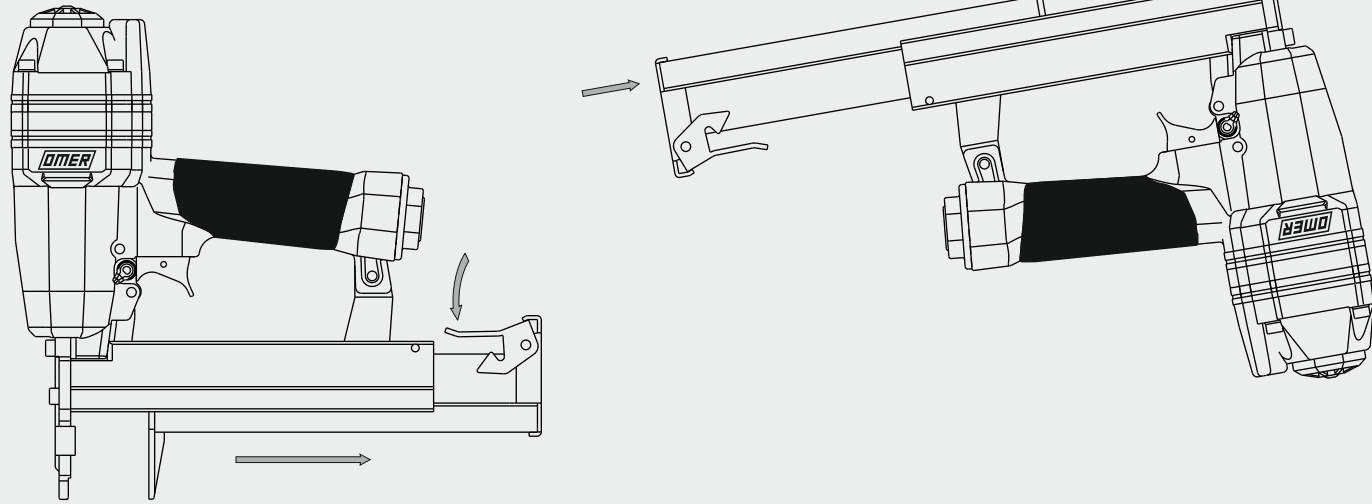

- Premere il grilletto chiusura
Press the magazine latch
- Arretrare il carrello
Pull the slider
- Capovolgere la graffatrice
Turn the tool up side down
- Inserire le graffe
Load the magazine with staples
- Chiudere il carrello
Shut the slider



Non azionare MAI il grilletto comando o la sicura a contatto durante il caricamento della graffatrice. NEVER pull the trigger or the contact safety while loading magazine.



Manuale d'uso, manutenzione e parti di ricambio
Use, maintenance and spare parts manual
Gebrauchsanweisung, Instandhaltungsrichtlinien und Ersatzteile
Manuel d'utilisation, entretien et pièces de rechange
Manual de uso, mantenimiento y repuestos
 Εγχειρίδιο χρήσης, συντήρησης και ανταλλακτικών
Manual de utilização, manutenção e partes sobresselentes
Handleiding voor gebruik, onderhoud en reservedelslste
Brugsanvisning, vedligeholdelse og reservedelslste

Parte 2
Part 2
Teil 2
Partie 2
Part 2
 2º Μερους
Parte 2
Deel 2
Del 2



90.38 BA

cod. 1427030A

1427030A_9038BA_2 270814 IV

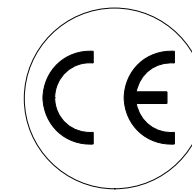

| Dati tecnici Technical data Technische daten | Données techniques Datos tècnicos Τεχνικά χαρακτηριστικά | Dados tècnicos Technischegegevens Teknische data |
|--|--|--|
|--|--|--|

| | | | |
|---|---|--|---|
| Misure impieghiabili mm Usable lengths mm Gebrauchliche Längen mm | Mesures utilisables mm Medidas que se pueden emplear mm Διαστάσεις σε μμ | Medidas que se podem utilizar mm Te gebruiken engtes in mm Brugbare laengder i mm | 15 ÷ 40 |
| Capacità caricatore n° punti Magazine capacity No. of fasteners Magazinkapazität Nägel | Capacité chargeur n° de points Capacidad cargador n° puntos Δυνατότητα γεμιστέρα, σπινδότερες | Capacidade carregador n° pontos Capaciteit magazijn in aantal spijkers Kapacitet af magasin antal klemme | 105 |
| Pressione d'esercizio Working pressure Betriebsdruck | Pression de fonctionnement Presión de trabajo Πίεση λειτουργίας ατμ. | Pressao de trabalho Werkdruk Arbejds tryk bar | 5 ÷ 7,5 bar 70 ÷ 105 psi |
| Consumo aria litri/colpo Air consumption litres/shot Luftverbrauch Liter/Schlag | Consommation air litre/coup Consumo aire-litros/golpe Καταναλοση αερα λ/ξετσημα | Consumo ar litro/golpe Luchtverbruik liter/schot Luftforbrug liter/skud | 0,58 |

| | | | |
|---|---|--|-------------------|
| Peso kg Weight kg Gewicht kg | Poids kg Peso kg Βαρος kg | Peso kg Gewicht in kg Vaegt kg | 1,59 |
| Dimensioni (AxBxH) mm Dimensions mm Größe mm | Dimension mm Dimensiones mm Δυνατότητα γεμιστέρα, σπινδότερες | Dimencoes mm Afmetingen in mm Dimensioner mm | 242x58x271 |

| EN 12549 :1999 | ISO 11201 :1995 | | |
|--|---|--|--|
| Pressione sonora in pos. operatore Sound pressure at the workstation Lärmintensität am Arbeitsplatz | Pression acoustique près de l'opérateur Presión sonora en posición encargado Ακουστική πίεση στη θέση χειριστου | Intensidade sonora perto do operador Geluidssterkte op de werkplek Lydstyrke på operatorposten | $L_{pA,1s}$ (Rif. 20μPa) 83,1 dB(A) |

| EN 12549 :1999 | ISO 3744 :1994 | | |
|---|---|--|--|
| Potenza sonora emessa Emitted sound power Ausgestrahlte Lärmintensität | Puissance acoustique émise Potencia sonora emitida Ακουστική ισχυ | Potência sonora emitida Uitgestraalde geluidssterkte Udsendt lydstryke | $L_{WA,1s}$ (Rif. 1pW) 92,9 dB(A) |

| EN 28662 :1992 | ISO 5349 :1986 | ISO 8662 -11 | |
|---|---|--|---|
| Valore medio ponderato di vibrazione sull'impugnatura Weighted mean value of vibration on the grip Mittlerer Vibrationswert, am Griff Gemessen | Valeur moyenne pondérée de vibration mesurée sur la poignée Valor medio ponderado de vibracion medida en la empuñadura Μεσοσ ορος μετρησης κραδασιμον στη χειρολαβη | Valor medio ponderado de vibracao medida no punho Gewogen gemiddelde vibratiewaarde Middelvaerdi af vibrationer pa handtaget | Sequential $a_{h,w}$ 6,4 m/s² Bump $a_{h,w}$ 6,06 m/s² |

Tipo di punto
Type of fastener
Befestigungselement
Type d'agrafe
Tipo de punto
Τυπος κάρφιου
Tipo de ponto
Type nietjes
Tilspændingstype

90

☑ 1,00x1,25

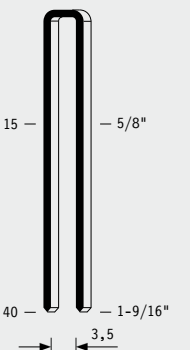

Gauge: 18
Crown: .217" (1/4")

Caratteristiche - Features

Colpo singolo Single shot

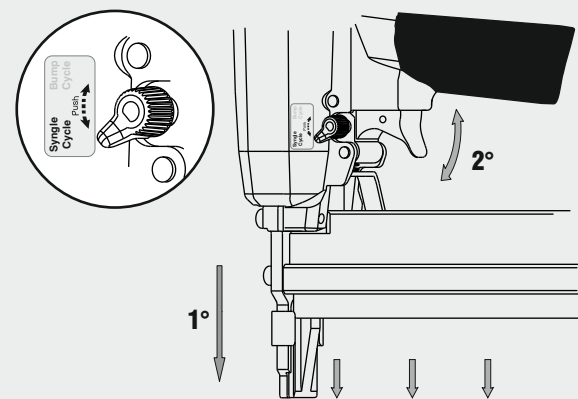

Colpo martello Bump fire

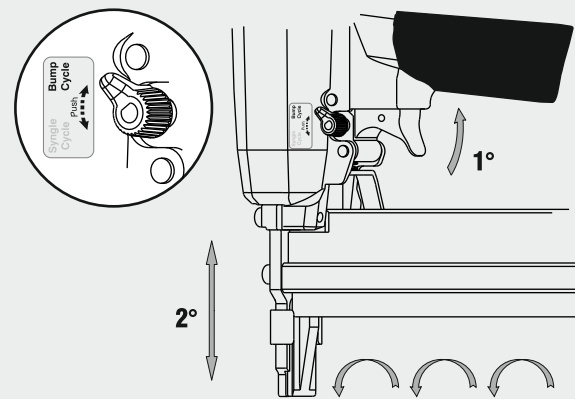

Parti di ricambio - Spare parts - Ersatzteile - Pièces de rechange - Piezas de repuesto
Ανταλλακτικά - Partes sobresselentes - Tabel te raadplegen - Reservedele

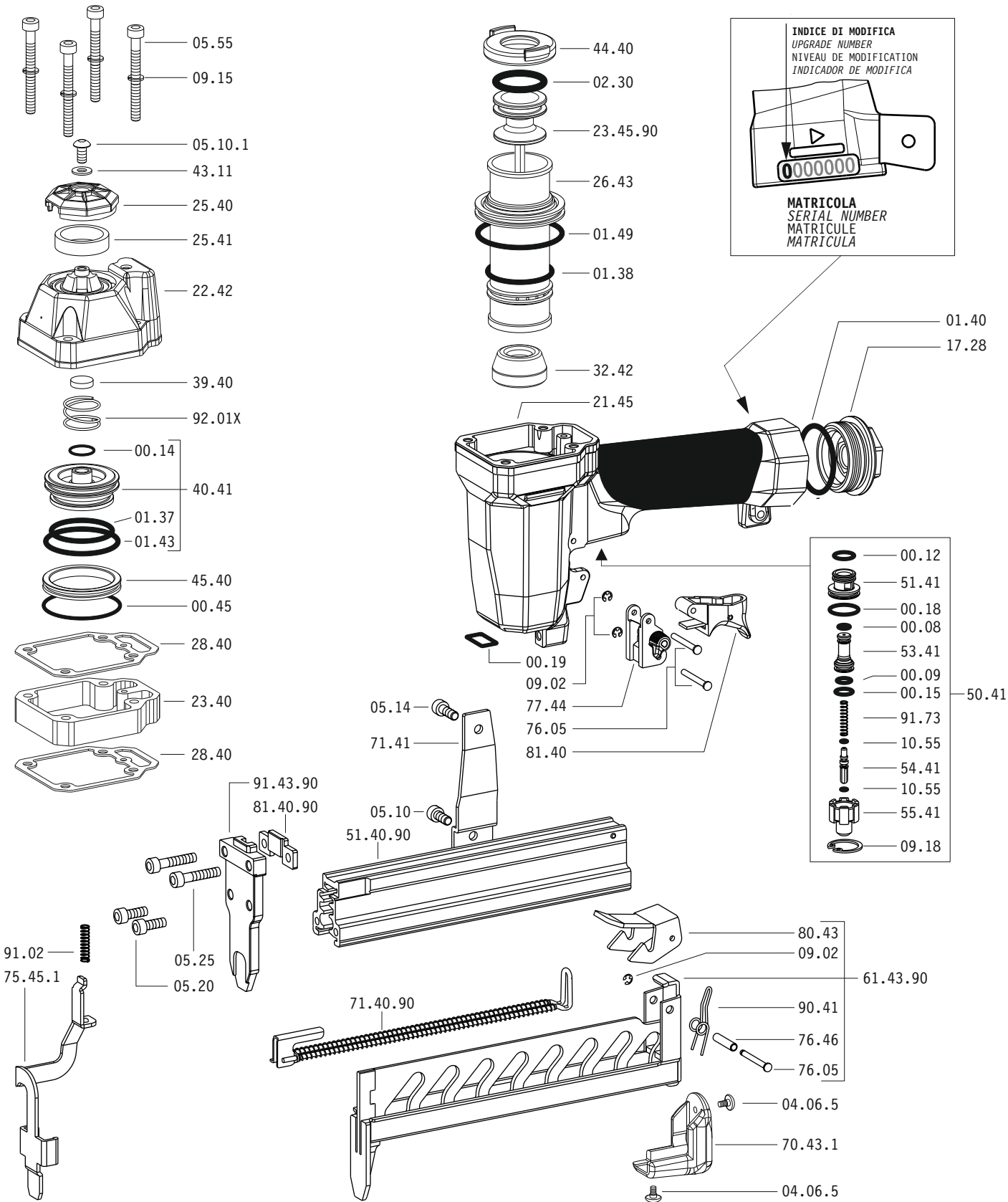

Dotazioni - Equipment - Ausrüstung - Équipements - Equipamiento - Παρεχόμενα
Equipamento - Uitrusting - Udstyr

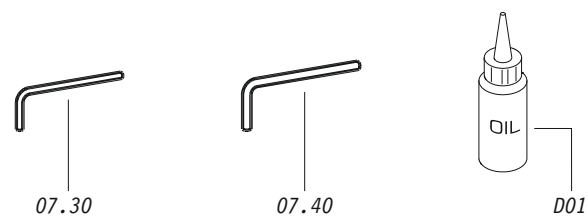

90.38 BA

cod. 1427030A

Parti di ricambio - Spare parts - Ersatzteile - Pièces de rechange - Piezas de repuesto
Ανταλλακτικά - Partes sobresselentes - Tabel te raadplegen - Reservedele

| Cod. | Descrizione | Description |
|----------|----------------------|-----------------------|
| 00.08 | O-Ring | O-Ring |
| 00.09 | O-Ring | O-Ring |
| 00.12 | O-Ring | O-Ring |
| 00.14 | O-Ring | O-Ring |
| 00.15 | O-Ring | O-Ring |
| 00.18 | O-Ring | O-Ring |
| 00.19 | O-Ring | O-Ring |
| 00.45 | O-Ring | O-Ring |
| 01.37 | O-Ring | O-Ring |
| 01.38 | O-Ring | O-Ring |
| 01.40 | O-Ring | O-Ring |
| 01.43 | O-Ring | O-Ring |
| 01.49 | O-Ring | O-Ring |
| 02.30 | O-Ring | O-Ring |
| 04.06.5 | Vite | Screw |
| 05.10 | Vite | Screw |
| 05.10.1 | Vite | Screw |
| 05.14 | Vite | Screw |
| 05.20 | Vite | Screw |
| 05.25 | Vite | Screw |
| 05.55 | Vite | Screw |
| 07.30 | Chiave esagonale | Hex. bar wrench |
| 07.40 | Chiave esagonale | Hex. bar wrench |
| 09.02 | Anello elastico | Elastic ring |
| 09.15 | Rondella | Washer |
| 09.18 | Anello elastico | Elastic ring |
| 10.55 | O-Ring | O-Ring |
| 17.28 | Tappo | Inlet cap |
| 21.45 | Corpo | Body |
| 22.42 | Testa | Head |
| 23.40 | Prolunga | Extension |
| 25.40 | Deflettore | Exhaust deflector |
| 25.41 | Silenziatore | Silencer |
| 26.43 | Cilindro | Cylinder |
| 28.40 | Guarnizione testa | Head gasket |
| 32.42 | Ammortizzatore | Bumper |
| 39.40 | Guarnizione scarico | Exhaust seal |
| 40.41 | Valvola completa | Valve ass'y |
| 43.11 | Rondella | Washer |
| 44.40 | Guarnizione | Gasket |
| 45.40 | Anello valvola | Ring |
| 50.41 | Pulsante completo | Trigger valve ass'y |
| 51.41 | Boccola pulsante | Trigger valve housing |
| 53.41 | Pistone servovalvola | Valve piston |
| 54.41 | Pulsante | Trigger valve |
| 55.41 | Raccordo pulsante | Bush |
| 70.43.1 | Protezione | Guard |
| 71.41 | Reggicaricatore | Support |
| 75.45.1 | Sicura | Safety |
| 76.05 | Perno | Pin |
| 76.46 | Perno molla | Pin |
| 77.44 | Guida sicura | Safety guide |
| 80.43 | Grilletto chiusura | Trigger |
| 81.40 | Grilletto comando | Trigger |
| 90.41 | Molla | Spring |
| 91.02 | Molla | Spring |
| 91.73 | Molla | Spring |
| 92.01X | Molla | Spring |
| 23.45.90 | Battente | Driver |
| 51.40.90 | Caricatore | Magazine |
| 61.43.90 | Carrello | Slider |
| 71.40.90 | Spingipunto | Pusher |
| 81.40.90 | Controtestina | Nose |
| 91.43.90 | Testina | Nose plate |
| D01 | Boccetta olio | Oiler |

Guarnizioni - O-Rings - Dichtungen - Joints - Kit O-Rings - Ασπινγκια - Kit O-Rings - O-ringen - Pakninger

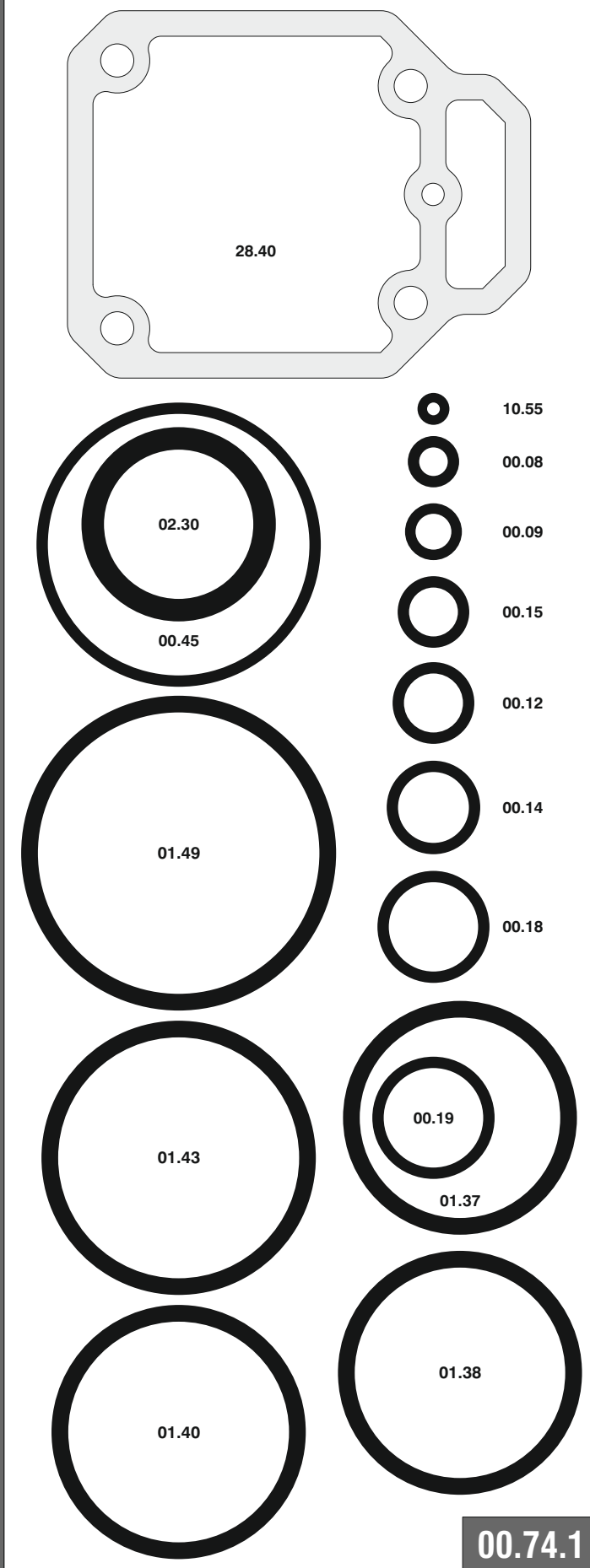

1427030A_9038BA_2 270814 IV

90.38 BA

cod. 1427030A

Indice di modifica
Upgrade number

2

2252608