

Schema di collegamento - Connecting diagram

Collegamento per valvola 3/2 NA

Connection for valve 3/2 NO

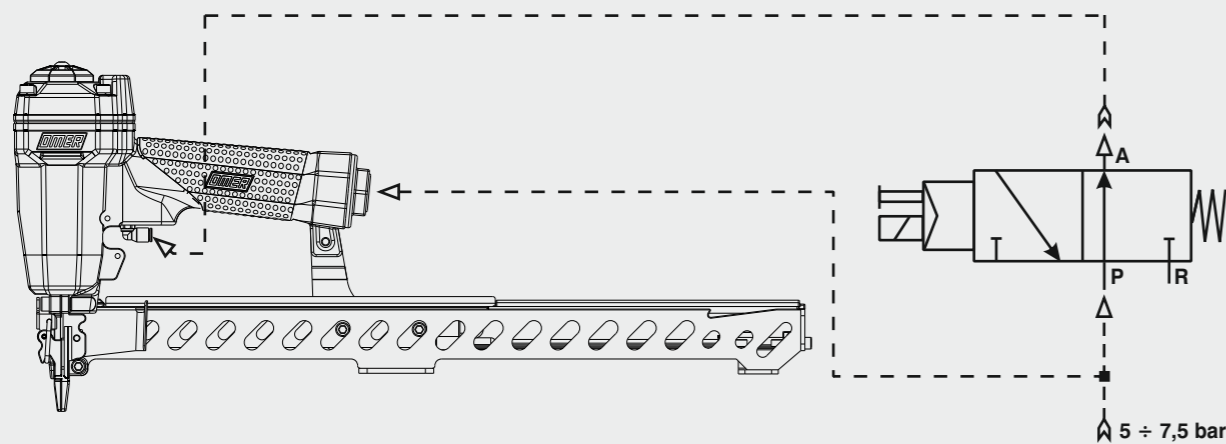

Caricamento - Loading

1 - Arretrare lo spingipunto e agganciarlo al fincorsa facendo aprire il Carter Mobile

Pull the pusher backwards and lock it at the stop position at the rear of the tool in this way the Movable Hold Down will open

2 - Inserire le graffe

Load the magazine with Staple

3 - Rilasciare lo spingipunto

Release the slider

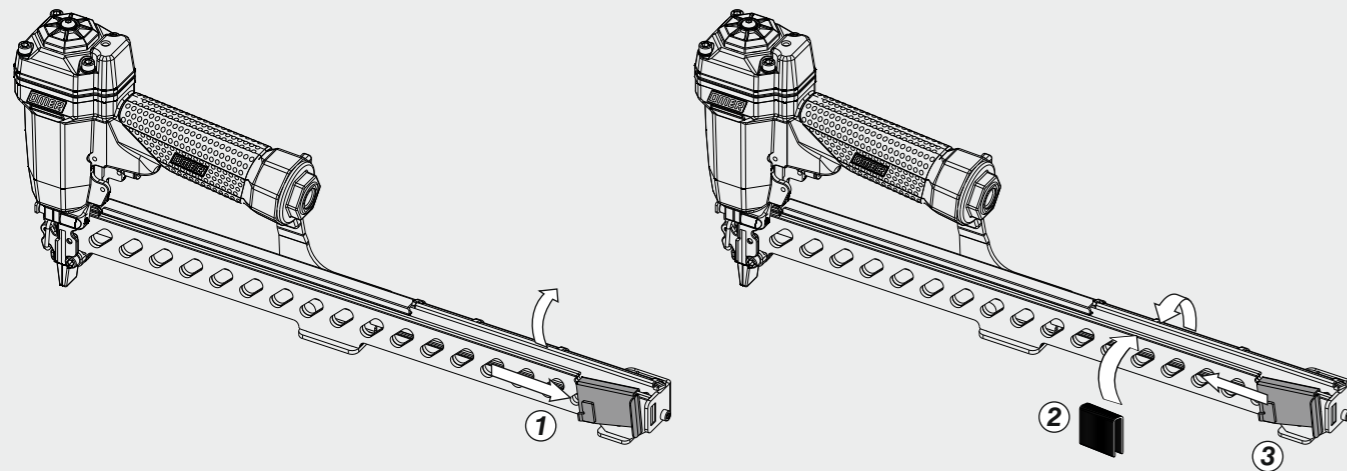

Disinceppamento macchina - Quick clearance jammed nails

Disinceppamento macchina

Quick clearance jammed staples

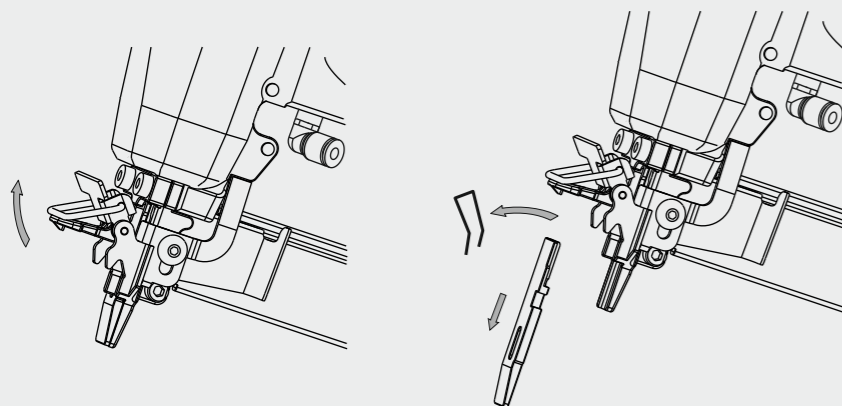

Non azionare MAI la valvola di comando durante il caricamento, disinceppamento della graffatrice.
NEVER actuate the command valve while loading magazine or clearing a jammed staple.

OMER

Manuale d'uso, manutenzione e parti di ricambio
Use, maintenance and spare parts manual
Gebrauchsanweisung, Instandhaltungsrichtlinien und Ersatzteile
Manuel d'utilisation, entretien et pièces de rechange
Manual de uso, mantenimiento y repuestos
Εγχειρίδιο χρήσης, συντήρησης και ανταλλακτικών
Manual de utilização, manutenção e partes sobresselentes
Handleiding voor gebruik, onderhoud en reservedeelslste
Brugsanvisning, vedligeholdelse og reservedeelslste

Parte 2
Part 2
Teil 2
Partie 2
Part 2
2º Μερὸς
Parte 2
Deel 2
Del 2



92.32 CLD3

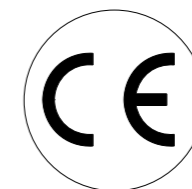

cod. 14272530D

14272530D_9232CLD3_2 280217 IV

Dati tecnici Technical data Technische daten	Données techniques Datos tècnicos Τεχνικά χαρακτηριστικά	Dados tècnicos Technischegegevens Teknische data
----------------------------------------------------	----------------------------------------------------------------	--------------------------------------------------------

Misure impiegabili mm Usable lengths mm Gebrauchliche Längen mm	Mesures utilisables mm Medidas que se pueden emplear mm Διαστάσεις σε μμ	Medidas que se podem utilizar mm Te gebruiken engtes in mm Brugbare laengder i mm	15 ÷ 32
Capacità caricatore n° punti Magazine capacity No. of fasteners Magazinkapazität Nägel	Capacité chargeur n° de points Capacidad cargador n° puntos Δυνατότητα γεμιστέρα, σπινδότερες	Capacidade carregador n° pontos Capaciteit magazijn in aantal spijkers Kapacitet af magasin antal klemme	300
Pressione d'esercizio Working pressure Betriebsdruck	Pression de fonctionnement Presión de trabajo Πίεση λειτουργίας ατμ.	Pressao de trabalho Werkdruk Arbejds tryk bar	5 ÷ 7,5 bar 70 ÷ 105 psi
Consumo aria litri/colpo Air consumption litres/shot Luftverbrauch Liter/Schlag	Consommation air litre/coup Consumo aire-litros/golpe Καταναλοση αερα λ/ξτσημα	Consumo ar litro/golpe Luchtverbruik liter/schot Luftforbrug liter/skud	0,45
Peso kg Weight kg Gewicht kg	Poids kg Peso kg Βαρος κγ	Peso kg Gewicht in kg Vaegt kg	1,78
Dimensioni (AxBxH) mm Dimensions mm Größe mm	Dimension mm Dimensiones mm Δυνατότητα γεμιστέρα, σπινδότερες	Dimencoes mm Afmetingen in mm Dimensioner mm	480x58x210

EN 12549 :1999	ISO 11201 :1995		
Pressione sonora in pos. operatore Sound pressure at the workstation Lärmintensität am Arbeitsplatz	Pression acoustique près de l'opérateur Presión sonora en posición encargado Ακουστική πίεση στη θέση χειριστού	Intensidade sonora perto do operador Geluidssterkte op de werkplek Lydstyrke på operatorposten	$L_{pA,1s}$ (Rif. 20μPa) 83,1 dB(A)

EN 12549 :1999	ISO 3744 :1994		
Potenza sonora emessa Emitted sound power Ausgestrahlte Lärmintensität	Puissance acoustique émise Potencia sonora emitida Ακουστική ισχυ	Potência sonora emitida Uitgestraalde geluidssterkte Udsendt lydstrykke	$L_{WA,1s}$ (Rif. 1pW) 92,9 dB(A)

EN 28662 :1992	ISO 5349 :1986	ISO 8662 -11	
Valore medio ponderato di vibrazione sull'impugnatura Weighted mean value of vibration on the grip Mitteler Vibrationswert, am Griff Gemessen	Valeur moyenne pondérée de vibration mesurée sur la poignée Valor medio ponderado de vibracion medida en la empuñadura Μεσοσ ορος μετρησης κραδασιμον στη χειρολαβη	Valor medio ponderado de vibracao medida no punho Gewogen gemiddelde vibratiewaarde Middelvaerdi af vibrationer pa handtaget	Sequential $a_{h,w}$ 6,4 m/s² Bump $a_{h,w}$ 6,06 m/s²

Tipo di punto
Type of fastener
Befestigungselement
Type d'agrafe
Tipo de punto
Τυπος καρφιου
Tipo de ponto
Type nietjes
Tilspændingstype

92

1,00x1,25

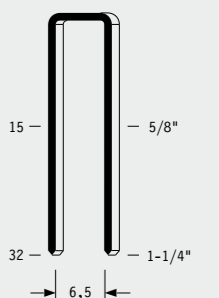

Crown: .330" (5/16")
Gauge: 18

Parti di ricambio - Spare parts - Ersatzteile - Pièces de rechange - Piezas de repuesto
Ανταλλακτικά - Partes sobresselentes - Tabel te raadplegen - Reservedele

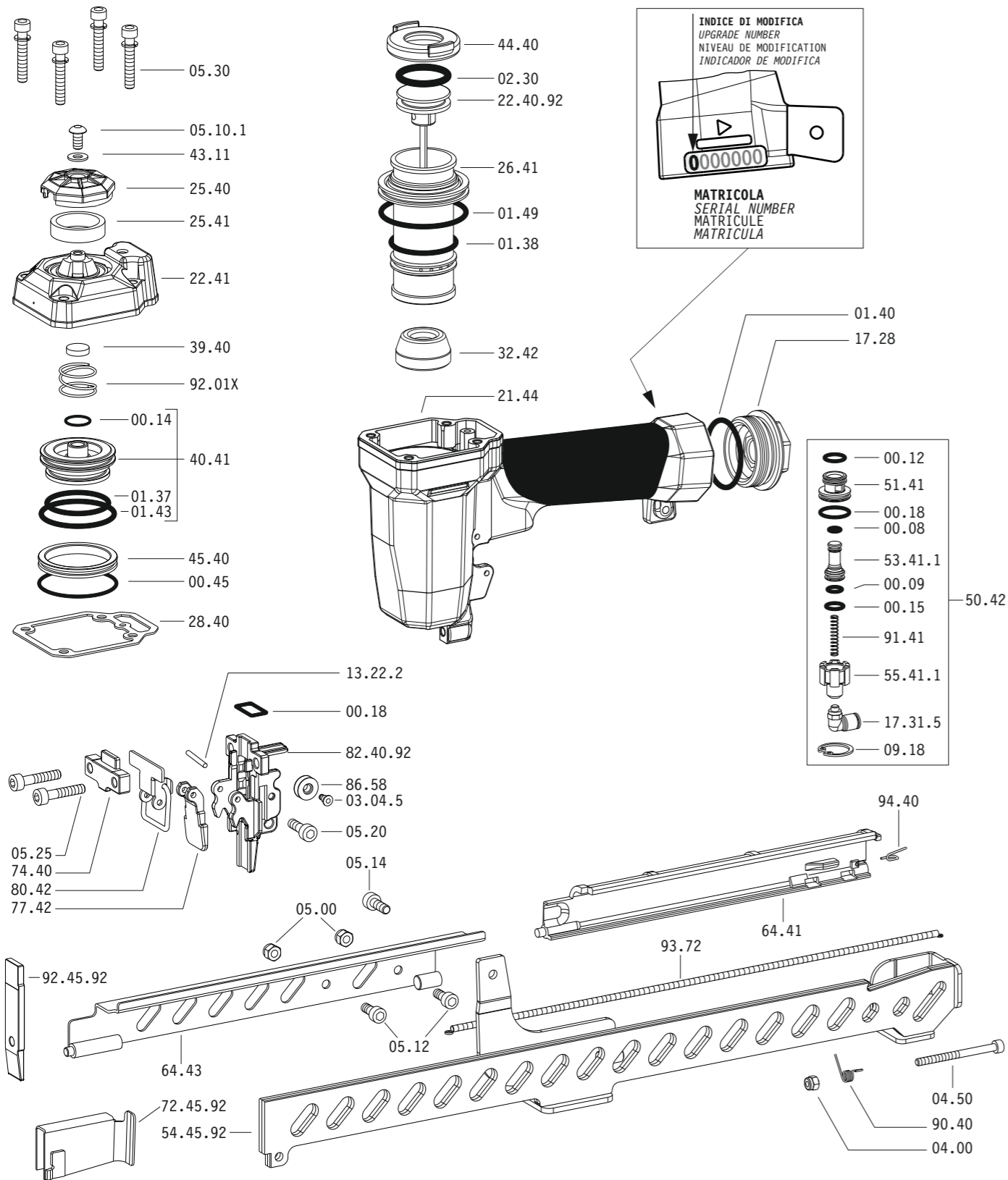

Dotazioni - Equipment - Ausrüstung - Équipements - Equipamiento - Παρεχόμενα
Equipamento - Uitrusting - Udstyr

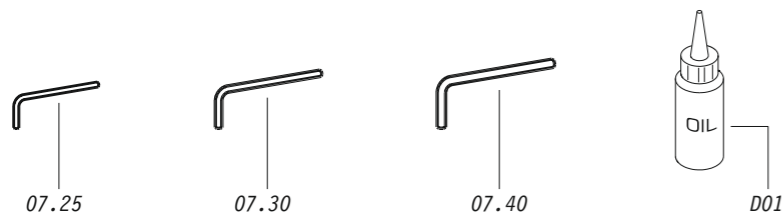

92.32 CLD3

cod. 14272530D

Parti di ricambio - Spare parts - Ersatzteile - Pièces de rechange - Piezas de repuesto
Ανταλλακτικά - Partes sobresselentes - Tabel te raadplegen - Reservedele

Cod.	Descrizione	Description
00.08	O-Ring	O-Ring
00.09	O-Ring	O-Ring
00.12	O-Ring	O-Ring
00.14	O-Ring	O-Ring
00.15	O-Ring	O-Ring
00.18	O-Ring	O-Ring
00.45	O-Ring	O-Ring
01.37	O-Ring	O-Ring
01.38	O-Ring	O-Ring
01.40	O-Ring	O-Ring
01.43	O-Ring	O-Ring
01.49	O-Ring	O-Ring
02.30	O-Ring	O-Ring
03.04.5	Vite	Screw
04.00	Dado	Nut
04.50	Vite	Screw
05.00	Dado	Nut
05.10.1	Vite	Screw
05.12	Vite	Screw
05.14	Vite	Screw
05.20	Vite	Screw
05.25	Vite	Screw
05.30	Vite	Screw
07.25	Chiave esagonale	Hex. bar wrench
07.30	Chiave esagonale	Hex. bar wrench
07.40	Chiave esagonale	Hex. bar wrench
09.18	Anello elastico	Elastic ring
13.22.2	Spina	Pin
17.28	Tappo	Inlet cap
17.31.5	Raccordo	Air plug
21.44	Corpo	Body
22.41	Testa	Head
25.40	Deflettore	Exhaust deflector
25.41	Silenziatore	Silencer
25.42	Supporto	Support
25.42-3	Distanziale	Spacer
26.41	Cilindro	Cylinder
28.40	Guarnizione testa	Head gasket
32.42	Ammortizzatore	Bumper
39.40	Guarnizione scarico	Exhaust seal
40.41	Valvola completa	Valve ass'y
43.11	Rondella	Washer
44.40	Guarnizione	Gasket
45.40	Anello valvola	Ring
50.42	Pulsante completo	Trigger valve ass'y
51.41	Boccola pulsante	Trigger valve housing
53.41.1	Pistone servovalvola	Valve piston
55.41.1	Raccordo pulsante	Bush
64.41	Carter	Hold down
64.43	Carter	Hold down
74.40	Staffa testina	Nose guide
77.42	Guida testina	Safety nose plate
80.42	Grilletto testina	Nose plate lock
86.58	Carrucola	Pulley
90.40	Molla	Spring
91.41	Molla	Spring
92.01X	Molla	Spring
93.72	Molla	Spring
94.40	Molla	Spring
22.40.92	Battente	Driver
54.45.92	Caricatore	Magazine
72.45.92	Spingipunto	Pusher
82.40.92	Controtestina	Nose
92.45.92	Testina	Nose plate
D01	Bocchetta olio	Oiler

Guarnizioni - O-Rings - Dichtungen - Joints - Kit O-Rings - Ασπριγάρια - Kit O-Rings - O-ringen - Pakninger

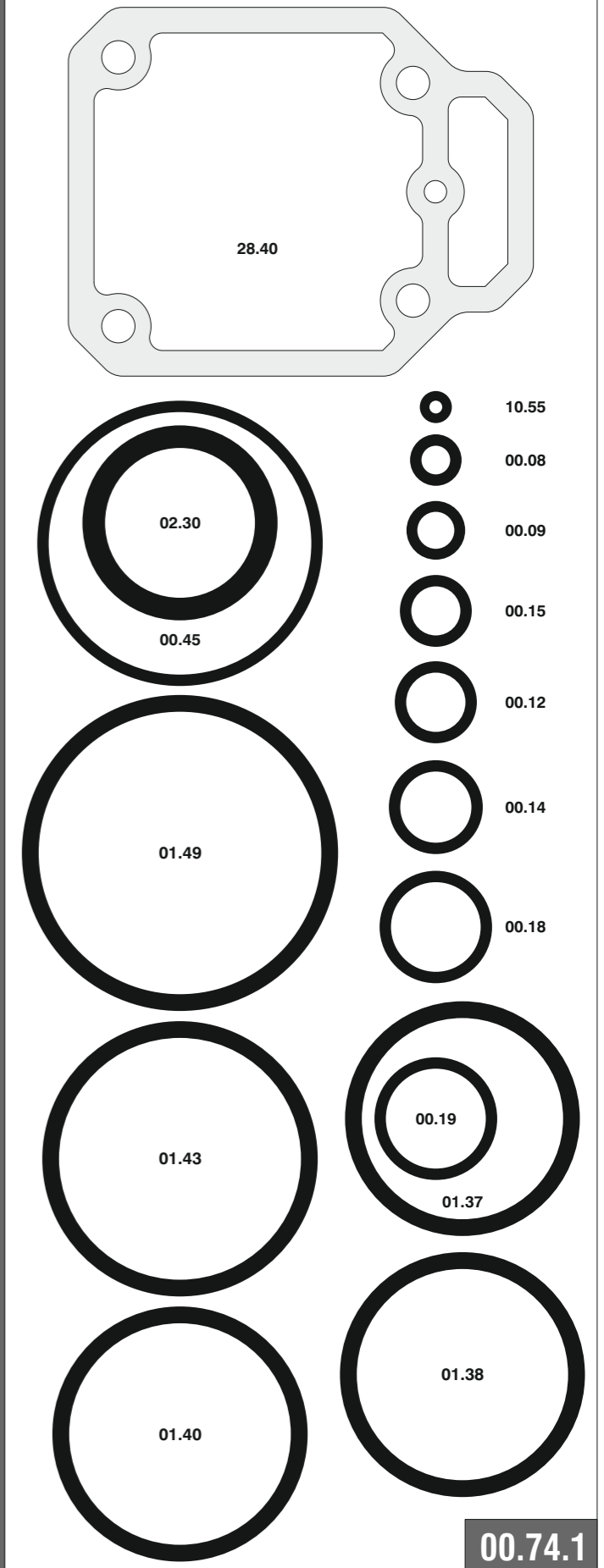

92.32 CLD3

cod. 14272530D

Indice di modifica
Upgrade number

2