

Colpo singolo
Single shot

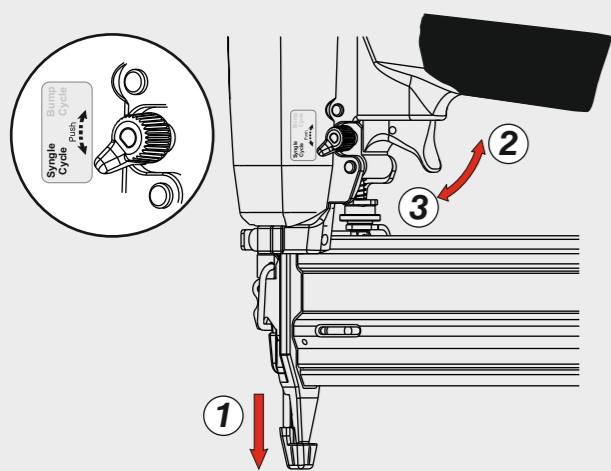

Colpo martello
Bump fire

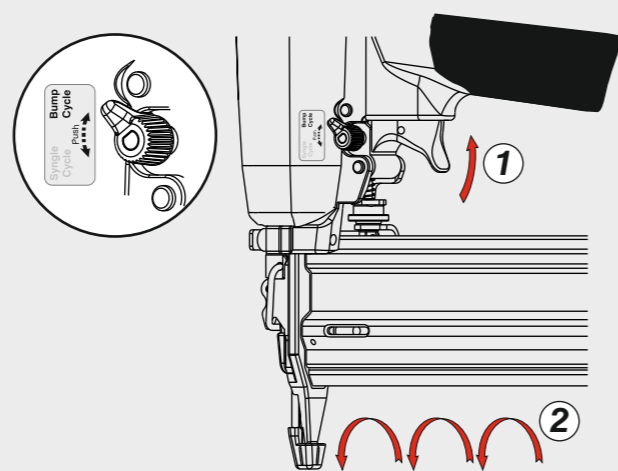

Caricamento - Loading - Laden - Chargement - Carga - Γέμισμα - Carregamento - Laden - Yükleme

Caricamento dal fianco
Side load magazine

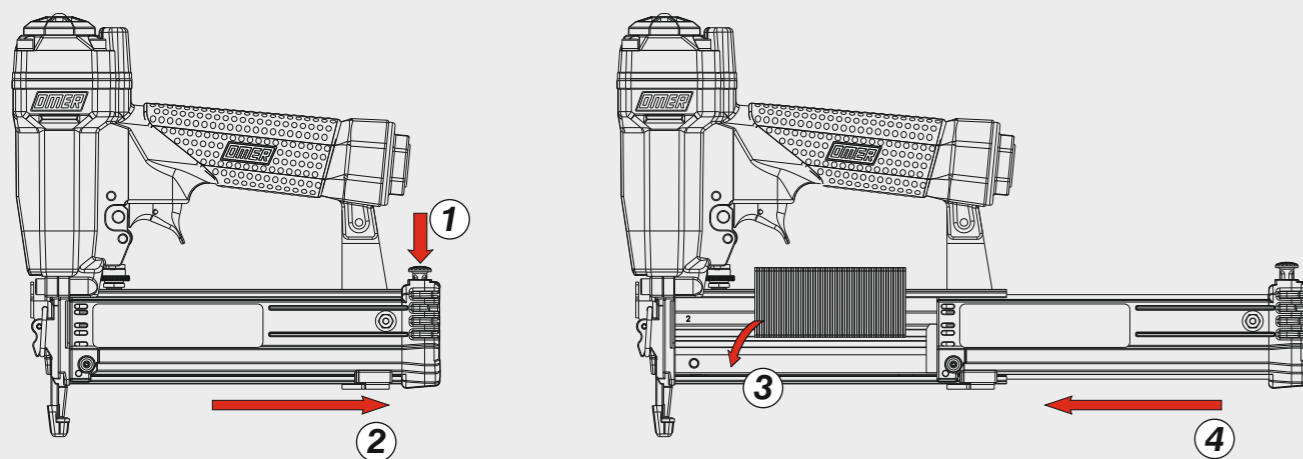

Regolazione di profondità - Depth adjustment - Tiefeneinstellung - Réglage des dimensions - Réglage des dimensions
Ρύθμιση βάθους - Regulação de profundidade - Diepte afstelling - Derinlik ayarı

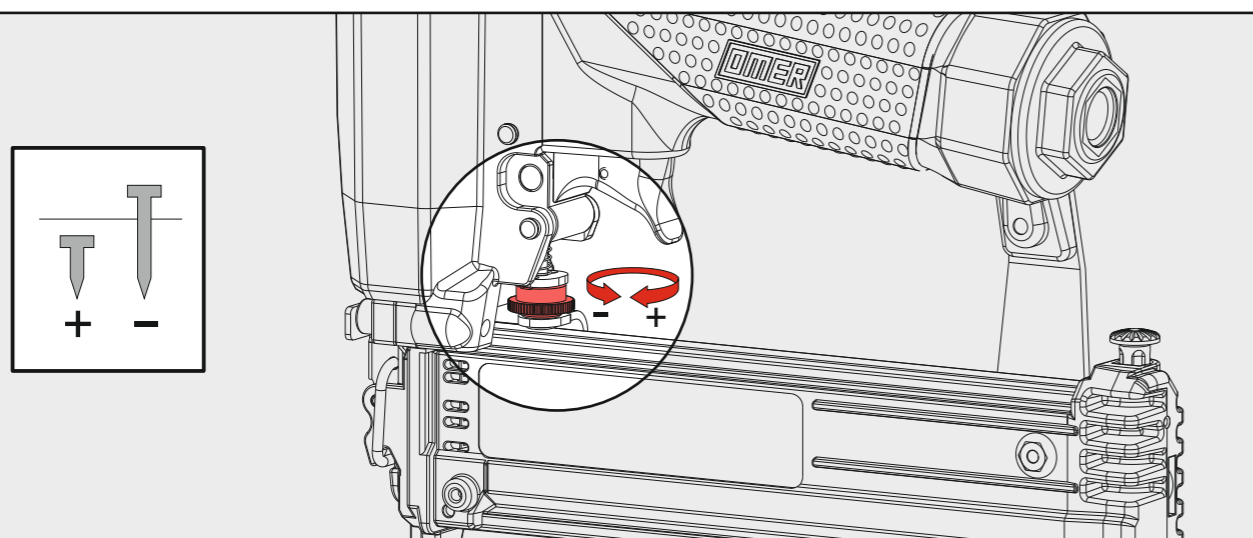

Manuale d'uso, manutenzione e parti di ricambio **Parte 2**
Manual for use, maintenance and spare parts **Part 2**
Bedienungs- und Wartungshandbuch sowie Ersatzteilleiste **Teil 2**
Mode d'emploi, de maintenance et pièces de rechange **Partie 2**
Manual de uso, mantenimiento y recambios **Part 2**
Εγχειρίδιο χρήσης, συντήρησης και ανταλλακτικών **Μέρος 2**
Manual de uso, manutenção e peças sobresselentes **Parte 2**
Handleiding voor gebruik, onderhoud en wisselstukken **Deel 2**
Kullanım, bakım ve yedek parça kılavuzu **Kısım 2**



12.50-0

cod. 1421200-0



Dati tecnici Technical data Technische Daten	Caractéristiques techniques Datos técnicos Τεχνικά χαρακτηριστικά	Dados técnicos Technische gegevens Teknik verier
Misure impiegabili mm Lengths mm Verwendbare Nagellänge mm	Dimensions utiles mm Medidas de longitud mm Μήκος Αναλωσίμου - mm	Medidas utilizáveis mm Toepasbare afmetingen mm Boy mm
		20 ÷ 50
Capacità caricatore n° punti Magazine capacity Magazinkapazität Nägel	Capacité chargeur n° de points Capacidad cargador n° puntos Δωνατοτητα γεμιστερα	Capacidade carregador n° pontos Capaciteit magazijn in aantal spijkers Dergi kapasitesi
		110
Pressione d'esercizio Operating pressure Betriebsdruck	Pression d'exercice Presión de servicio Πίση λειτουργίας	Pressão de serviço Werkdruk Çalışma basıncı
		5 ÷ 7,5 bar 70 ÷ 105 psi
Consumo aria litri/colpo Air consumption litres/stroke Luftverbrauch Liter/Schuss	Consommation d'air litres/coup Consumo aire litros/golpe Κατανάλωση αέρα - λίτρα/βολή	Consumo ar litros/disparo Luchtverbruik liter/slag Litre/vuruş hava tüketimi
		0,54
Peso kg Weight kg Gewicht kg	Poids kg Peso kg Βάρος - kg	Peso kg Gewicht in kg Ağırlık kg
		1,35
Dimensioni mm Dimensions mm Abmessungen mm	Dimensions mm Dimensiones mm Διαστάσεις mm	Dimensões mm Afmetingen mm Boyutlar mm
		229x58x250 (LxWxH)
UNI EN 12549 :2009 UNI EN ISO 4871 :2009		
Pressione sonora in pos. operatore Sound pressure in operator's position Schalldruck am Arbeitsplatz	Pression sonore poste Opérateur Presión sonora en la pos. del operador Ηχητική πίεση στη θέση του χειριστή	Pressão sonora na posição Operador Geluidsdruk op de werkplaats Operatör pozisyonunda ses basıncı
		84 dB(A) (K= 4 dB)
UNI EN 12549 :2009 UNI EN ISO 3746 :2011 UNI EN ISO 4871 :2009		
Potenza sonora emessa Sound power emitted Emittierte Schallleistung	Puissance sonore émise Potencia sonora emitida Εκπεμπόμενη ηχητική ισχύς	Potência sonora emitida Geëmitteerd geluidsvermogen Çıkan ses gücü (ses desibel)
		93 dB(A) (K= 4 dB)
UNI CEN ISO/TS 8662-11 :2006 UNI EN ISO 5349-2 :2004 UNI EN 12096 :1999		
Emissione vibratoria sull'impugnatura Vibratory emissions on handle Vibrationsemission am Griff	Émission vibratoire sur la prise en main Emisión de vibraciones en la empuñadura Εκπεμπόμενες δονήσεις στη λαβή	Emissão vibratória na empunhadura Trillingsemissie op de handgreep Tutamak üzerinde vibrasyon emisyonları
		2,68 m/s² (K= 2 m/s ²)

Tipo di punto
Type of fastener
Befestigungsmittel
Type de rivet
Tipo de punto
Τύπος αναλωσίμου
Tipo de agrafa
Type nietjes
Zimba ve çivi tipleri

Brads 12

☒ 1,00x1,25

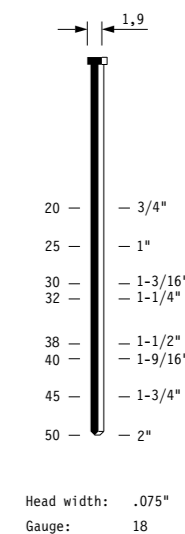

Parti di ricambio - Spare parts - Ersatzteile - Pièces de rechange - Recambios
Ανταλλακτικά - Partes sobresselentes - Wisselstukken - Yedek parçalar

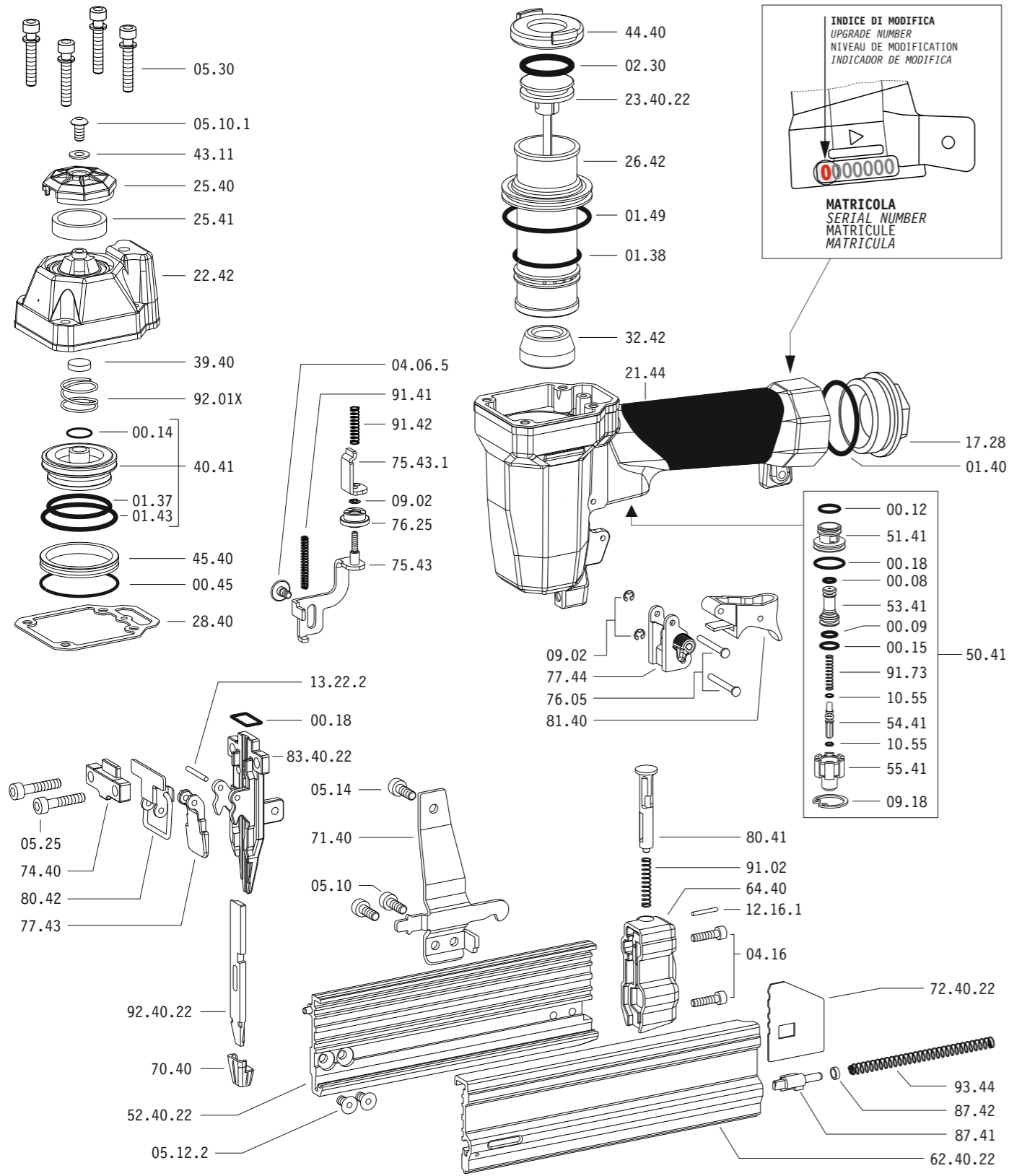

Dotazioni - Equipment - Ausstattung - Outillage - Dotaciones - Εξοπλισμός
Dotações - Uitrusting - Donanımlar



12.50-0
cod. 1421200-0

Parti di ricambio - Spare parts - Ersatzteile - Pièces de rechange - Recambios
Ανταλλακτικά - Partes sobresselentes - Wisselstukken - Yedek parçalar

Cod.	Descrizione	Description
00.08	O-Ring	O-Ring
00.09	O-Ring	O-Ring
00.12	O-Ring	O-Ring
00.14	O-Ring	O-Ring
00.15	O-Ring	O-Ring
00.18	O-Ring	O-Ring
00.45	O-Ring	O-Ring
01.37	O-Ring	O-Ring
01.38	O-Ring	O-Ring
01.40	O-Ring	O-Ring
01.43	O-Ring	O-Ring
01.49	O-Ring	O-Ring
02.30	O-Ring	O-Ring
04.06.5	Vite	Screw
04.16	Vite	Screw
05.10	Vite	Screw
05.10.1	Vite	Screw
05.12.2	Vite	Screw
05.14	Vite	Screw
05.25	Vite	Screw
05.30	Vite	Screw
07.30	Chiave esagonale	Hex. bar wrench
07.40	Chiave esagonale	Hex. bar wrench
09.02	Anello elastico	Elastic ring
09.18	Anello elastico	Elastic ring
10.55	O-Ring	O-Ring
12.16.1	Spina	Pin
13.22.2	Spina	Pin
17.28	Tappo	Inlet cap
21.44	Corpo	Body
22.42	Testa	Head
25.40	Deflettore	Exhaust deflector
25.41	Silenziatore	Silencer
26.42	Cilindro	Cylinder
28.40	Guarnizione testa	Head gasket
32.42	Ammortizzatore	Bumper
39.40	Guarnizione scarico	Exhaust seal
40.41	Valvola completa	Valve ass'y
43.11	Rondella	Washer
44.40	Guarnizione	Gasket
45.40	Anello valvola	Ring
50.41	Pulsante completo	Trigger valve ass'y
51.41	Boccola pulsante	Trigger valve housing
53.41	Pistone servovalvola	Valve piston
54.41	Pulsante	Trigger valve
55.41	Raccordo pulsante	Bush
64.40	Fondello	Cap
70.40	Puntale	Contact tip
71.40	Reggicaricatore	Support
74.40	Staffa testina	Nose guide
75.43	Sicura	Safety
75.43.1	Rinvio sicura	Contact arm
76.05	Perno	Pin
76.25	Regolatore	Adjusting wheel
77.43	Guida testina	Safety nose plate
77.44	Guida sicura	Safety guide
80.41	Grilletto chiuso	Magazine lock trigger
80.42	Grilletto testina	Nose plate lock
81.40	Grilletto comando	Trigger
87.41	Portamolla	Spring bearing
87.42	Segnalatore	Signal washer
91.02	Molla	Spring
91.41	Molla	Spring
91.42	Molla	Spring
91.73	Molla	Spring
92.01X	Molla	Spring
93.44	Molla	Spring
23.40.22	Battente	Driver
52.40.22	Caricatore	Magazine
62.40.22	Carrello	Slider
72.40.22	Spingipunto	Pusher
83.40.22	Controtestina	Nose
92.40.22	Testina	Nose plate
D01	Bocchetta olio	Oiler

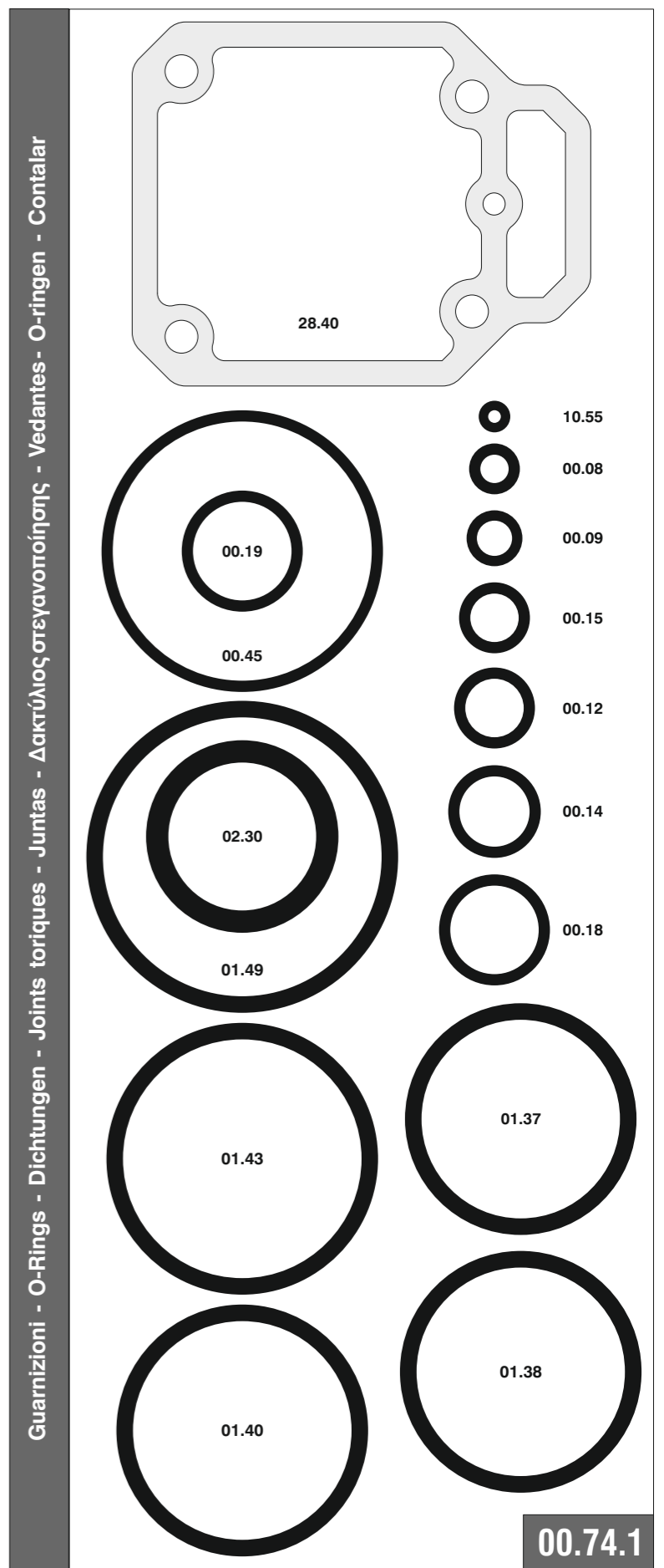

12.50-0 Indice di modifica / Upgrade number **2**
cod. 1421200-0

Disincceppamento - Jam clearing - Staubeseitigung - Décoincement - Desatascamiento - Απεμπλοκή
Desencravamento - Deblokkering bij vastlopen - Sikişma giderme

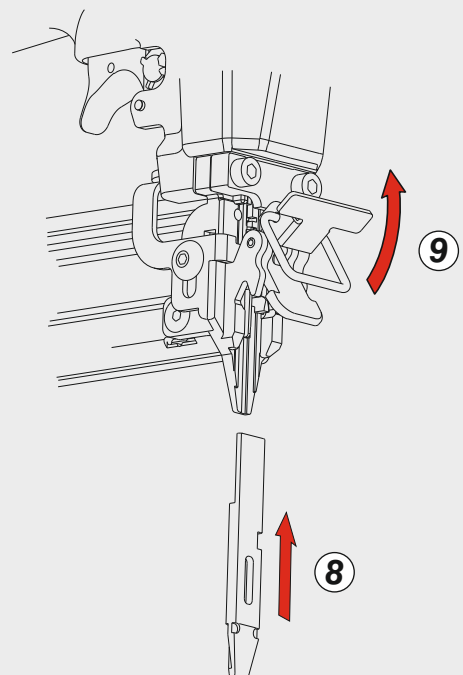
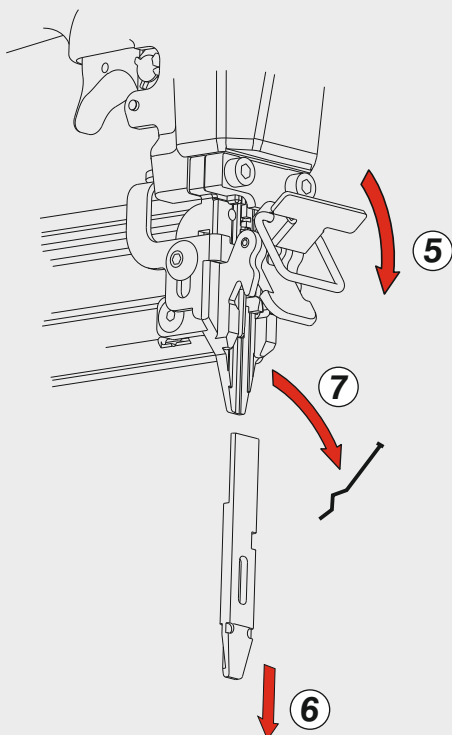
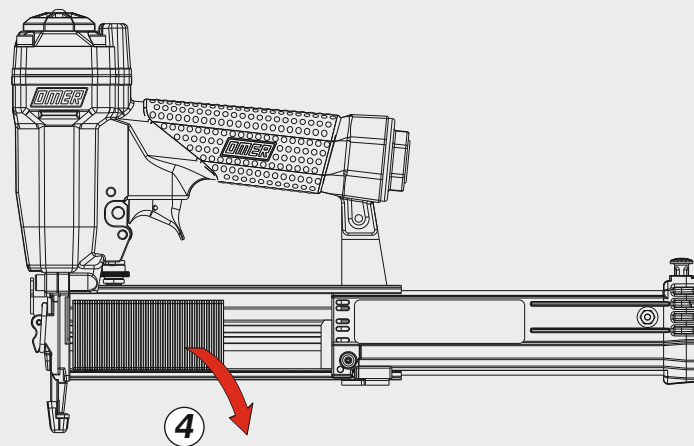
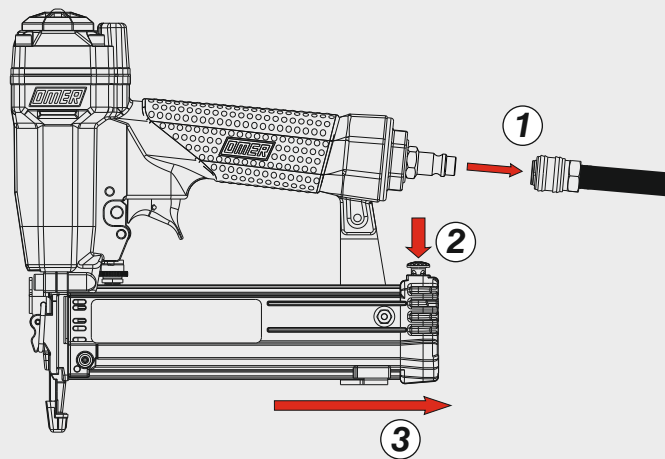

Segnalatore punti rimanenti

Fastener quantity indicator

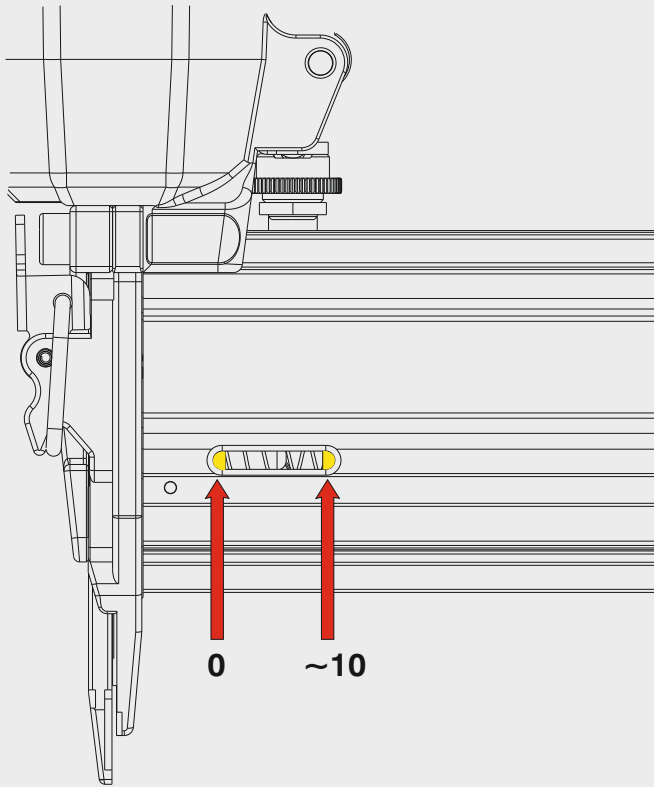

Dispositivo di blocco sparo a fine punti

Stop firing device on empty magazine

