

Colpo singolo
Single shot

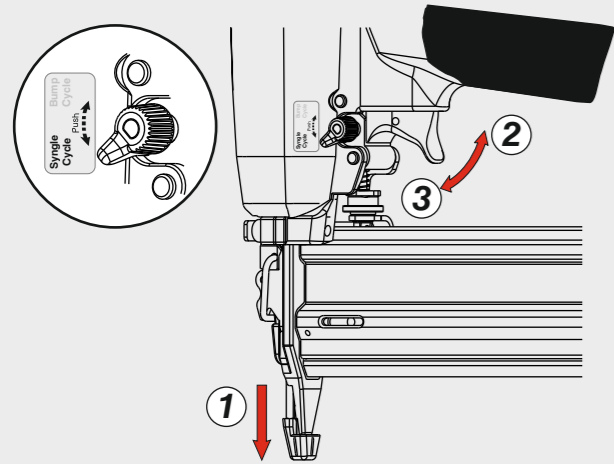

Colpo martello
Bump fire

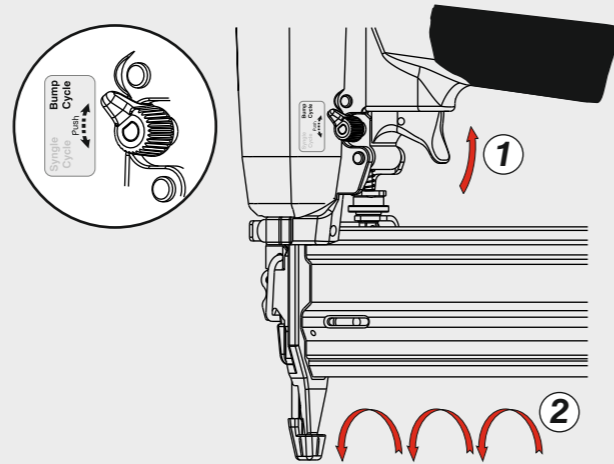

Caricamento - Loading - Laden - Chargement - Carga - Γέμισμα - Carregamento - Laden - Yükleme

Caricamento dal fianco
Side load magazine

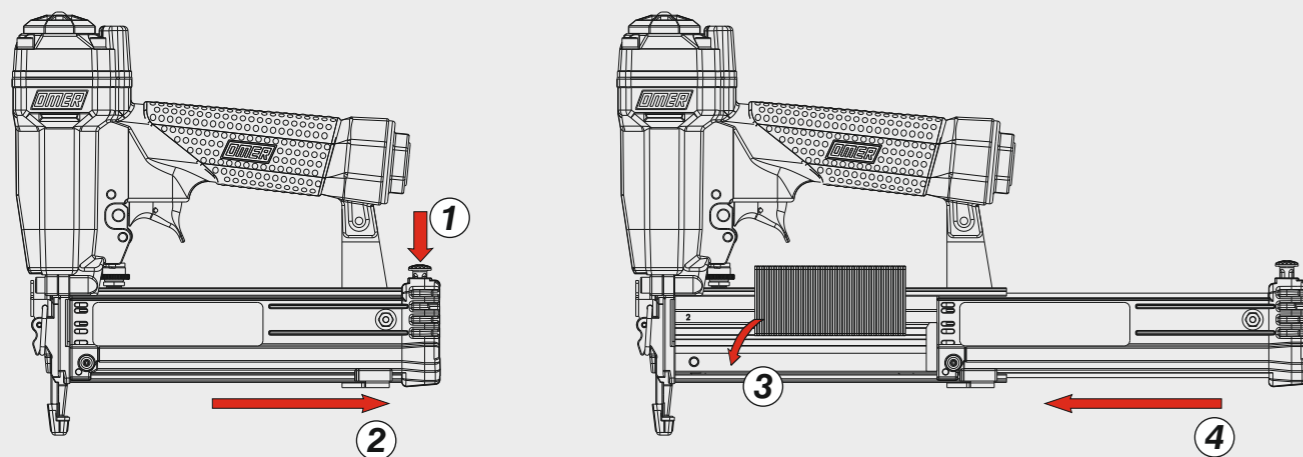

Regolazione di profondità - Depth adjustment - Tiefeneinstellung - Réglage des dimensions - Réglage des dimensions
Ρύθμιση βάθους - Regulação de profundidade - Diepte afstelling - Derinlik ayarı

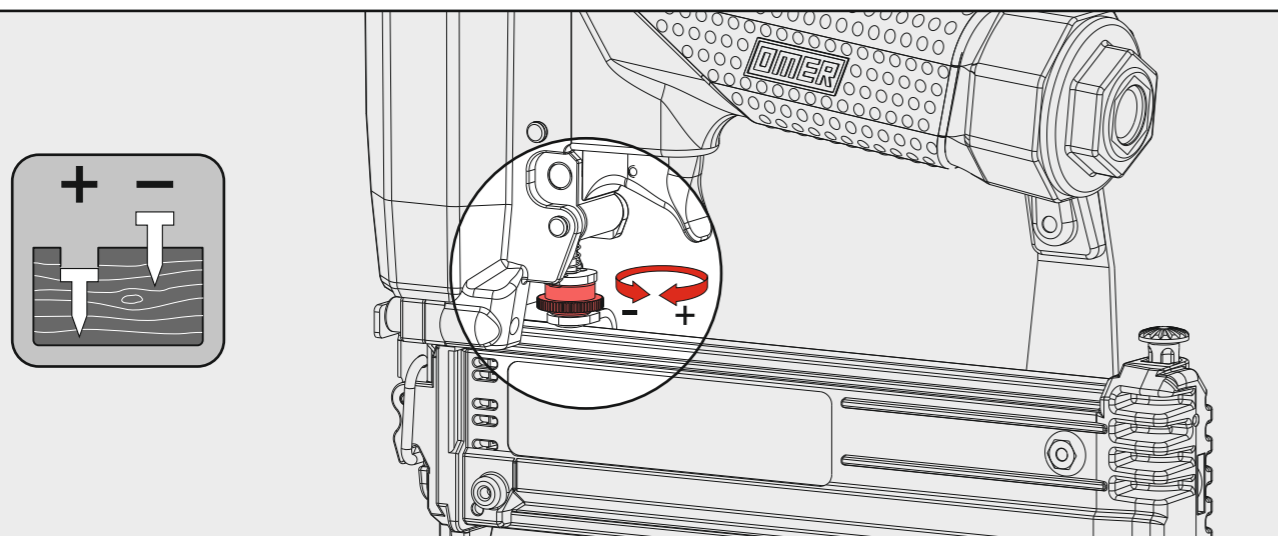

Manuale d'uso, manutenzione e parti di ricambio **Parte 2**
Manual for use, maintenance and spare parts **Part 2**
Bedienungs- und Wartungshandbuch sowie Ersatzteilleiste **Teil 2**
Mode d'emploi, de maintenance et pièces de rechange **Partie 2**
Manual de uso, mantenimiento y recambios **Part 2**
Εγχειρίδιο χρήσης, συντήρησης και ανταλλακτικών **Μέρος 2**
Manual de uso, manutenção e peças sobresselentes **Parte 2**
Handleiding voor gebruik, onderhoud en wisselstukken **Deel 2**
Kullanım, bakım ve yedek parça kılavuzu **Kısım 2**



14.50 A-0

cod. 1421420-0



Dati tecnici Technical data Technische Daten	Caractéristiques techniques Datos técnicos Τεχνικά χαρακτηριστικά	Dados técnicos Technische gegevens Teknik verier
Misure impiegabili mm Lengths mm Verwendbare Nagellänge mm	Dimensions utiles mm Medidas de longitud mm Μήκος Αναλωσίμου - mm	Medidas utilizáveis mm Toepasbare afmetingen mm Boy mm
Capacità caricatore n° punti Magazine capacity Magazinkapazität Nägel	Capacité chargeur n° de points Capacidad cargador n° puntos Δωνατοτητα γεμιστερα	Capacidade carregador n° pontos Capaciteit magazijn in aantal spijkers Dergi kapasitesi
Pressione d'esercizio Operating pressure Betriebsdruck	Pression d'exercice Presión de servicio Πίεση λειτουργίας	Pressão de serviço Werkdruk Çalışma basıncı
Consumo aria litri/colpo Air consumption litres/stroke Luftverbrauch Liter/Schuss	Consommation d'air litres/coup Consumo aire litros/golpe Κατανάλωση αέρα - λίτρα/βολή	Consumo ar litros/disparo Luchtverbruik liter/slag Litre/vuruş hava tüketimi
Peso kg Weight kg Gewicht kg	Poids kg Peso kg Βάρος - kg	Peso kg Gewicht in kg Ağırlık kg
Dimensioni mm Dimensions mm Abmessungen mm	Dimensions mm Dimensiones mm Διαστάσεις mm	Dimensões mm Afmetingen mm Boyutlar mm
UNI EN 12549 :2009 UNI EN ISO 4871 :2009 Pressione sonora in pos. operatore Sound pressure in operator's position Schalldruck am Arbeitsplatz	Pression sonore poste Opérateur Presión sonora en la pos. del operador Ηχητική πίεση στη θέση του Χειριστή	Pressão sonora na posição Operador Geluidsdruk op de werkplaats Operatör pozisyonunda ses basıncı
UNI EN 12549 :2009 UNI EN ISO 3746 :2011 UNI EN ISO 4871 :2009 Potenza sonora emessa Sound power emitted Emittierte Schallleistung	Puissance sonore émise Potencia sonora emitida Εκπεμπόμενη ηχητική ισχύς	Potência sonora emitida Geëmitteerd geluidsvermogen Çıkan ses gücü (ses desibel)
UNI CEN ISO/TS 8662-11 :2006 UNI EN ISO 5349-2 :2004 UNI EN 12096 :1999 Emissione vibratoria sull'impugnatura Vibratory emissions on handle Vibrationsemission am Griff	Émission vibratoire sur la prise en main Emisión de vibraciones en la empuñadura Εκπεμπόμενες δονήσεις στη λαβή	Emissão vibratória na empunhadura Trillingsemissie op de handgreep Tutamak üzerinde vibrasyon emisyonları

Tipo di punto
Type of fastener
Befestigungsmittel
Type de rivet
Tipo de punto
Τύπος αναλωσίμου
Tipo de agrafa
Type nietjes
Zimba ve çivi tipleri

Brads 14

1,40x1,60

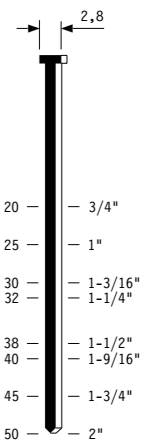

Head width: .108"
Gauge: 16

1421420-0_1450A-0_2_rev20_14112/2021 FL

Disinceppamento - Jam clearing - Staubeseitigung - Décoincement - Desatascamiento - Απεμπλοκή
Desencravamento - Deblokkering bij vastlopen - Sıkışma giderme

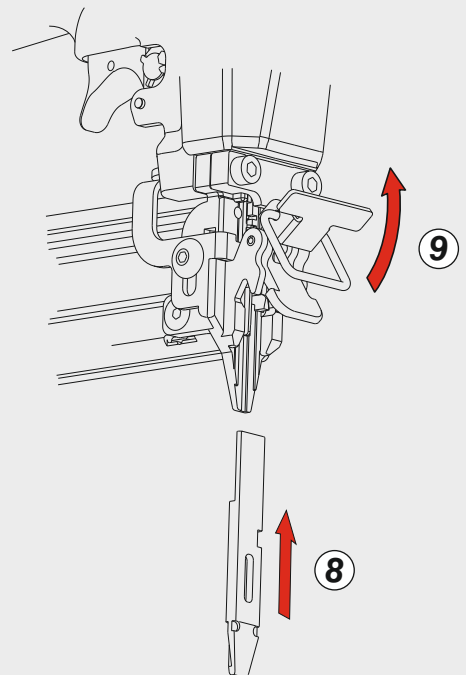
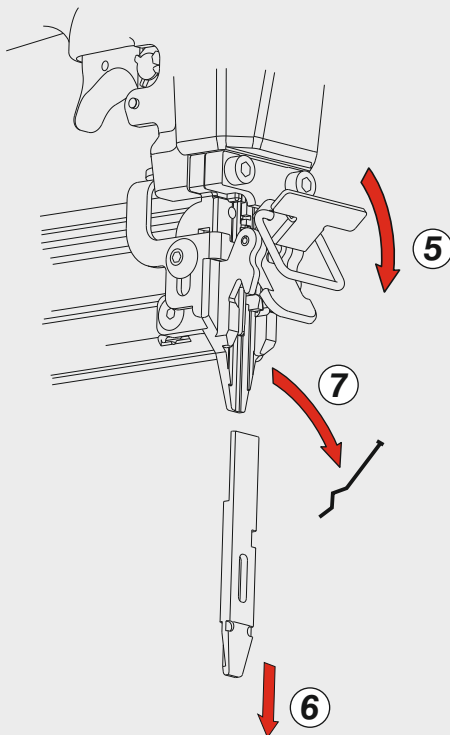
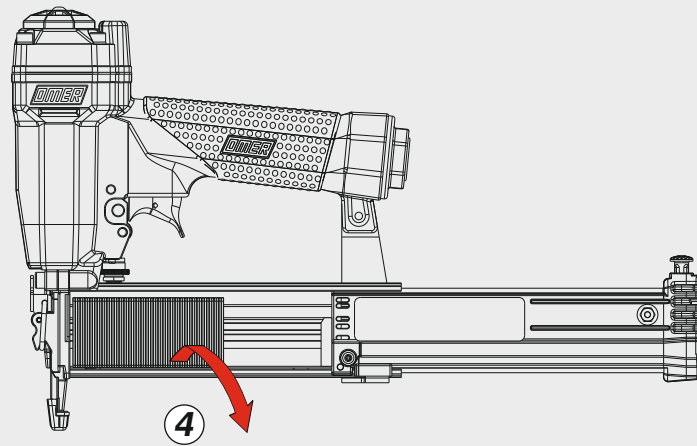
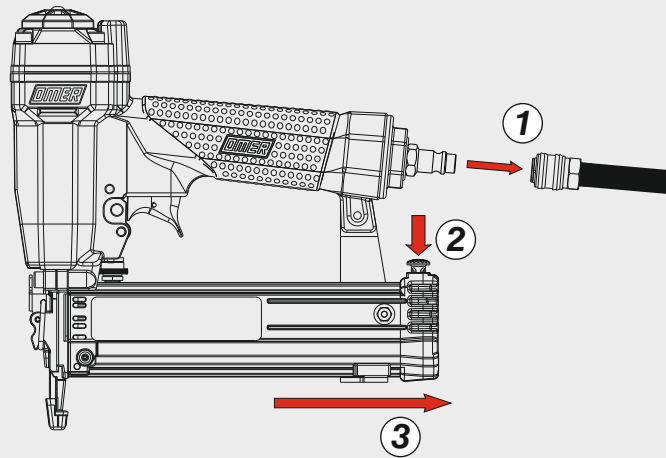

Segnalatore punti rimanenti

Fastener quantity indicator

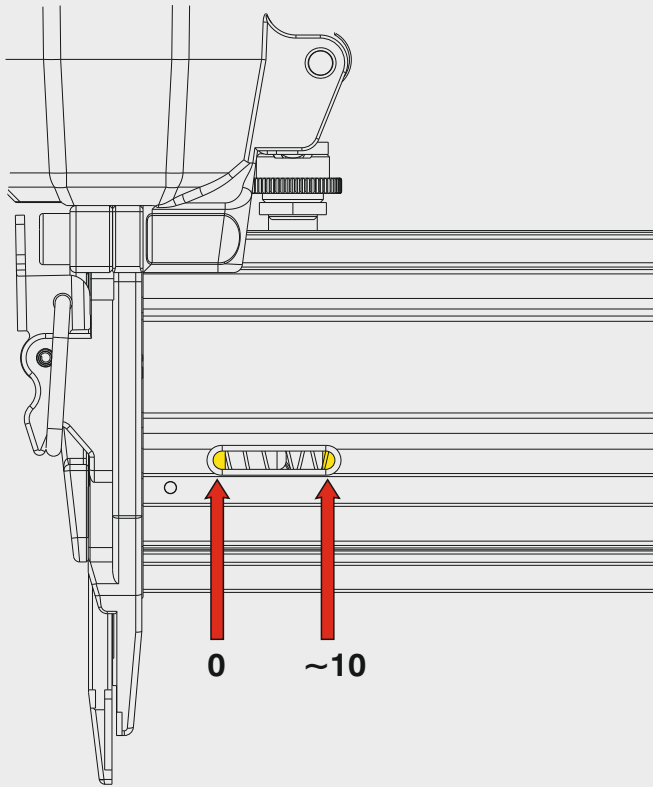

Dispositivo di blocco sparo a fine punti

Stop firing device on empty magazine

