

**Azionamento a contatto**

Contact actuation

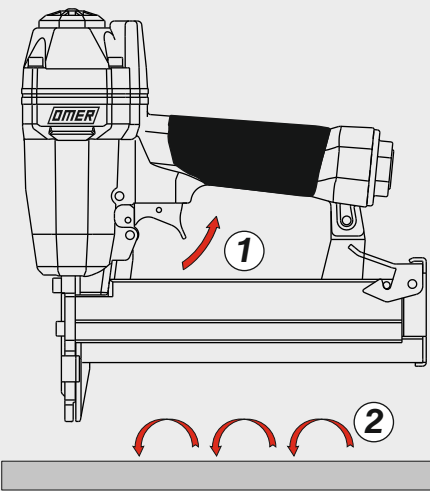

Oppure - Or

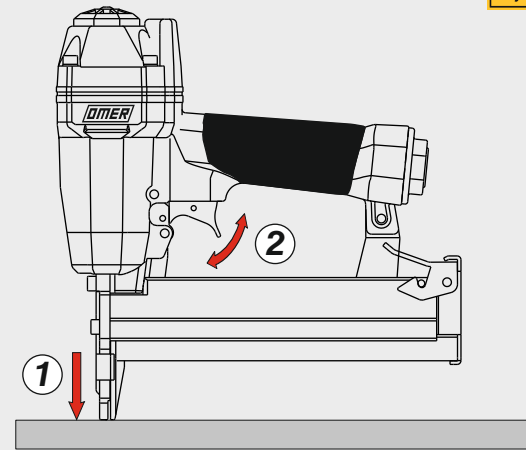

Caricamento - Loading - Laden - Chargement - Carga - Γέμισμα - Carregamento - Laden - Yükleme

**Caricamento da sotto**

Bottom load magazine

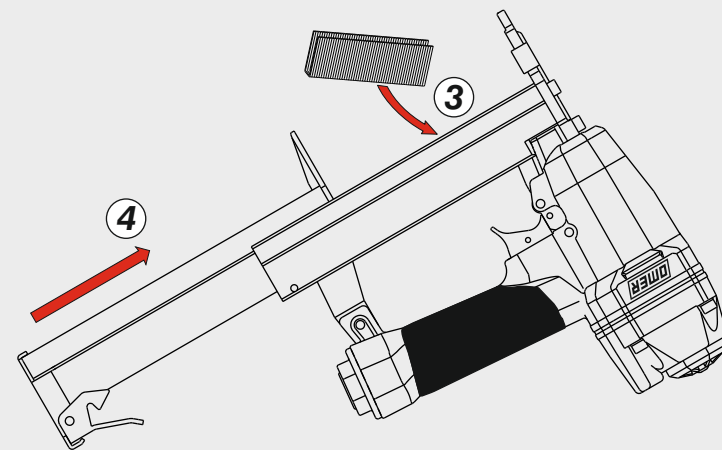
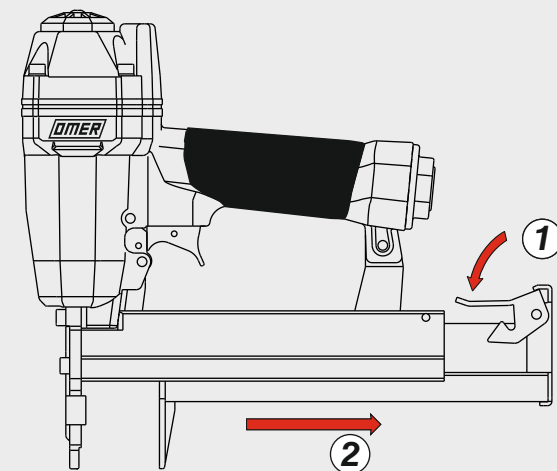

Disinceppamento - Jam clearing - Staubeseitigung  
Décoincement - Desatascamiento  
Απεμπλοκή - Desencravamento  
Deblokkering bij vastlopen - Sıkışma giderme

Regolazione di profondità - Depth adjustment  
Tiefeneinstellung - Réglage des dimensions  
Ρύθμιση βάθους  
Regulação de profundidade - Diepte afstelling - Derinlik ayarı

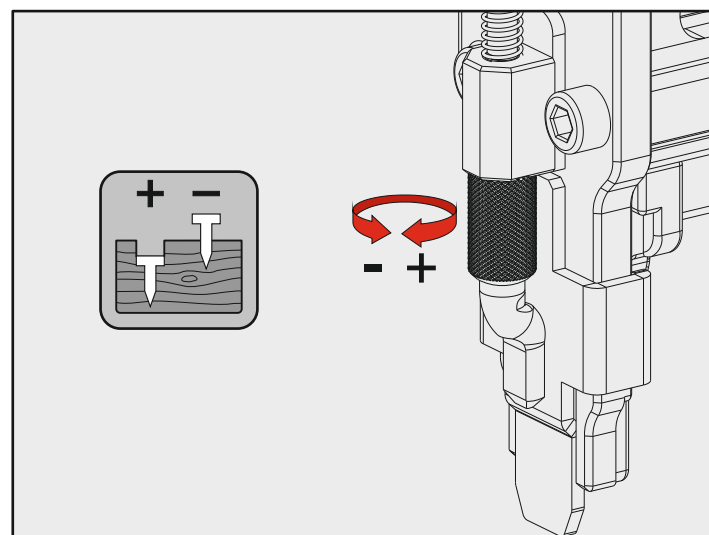
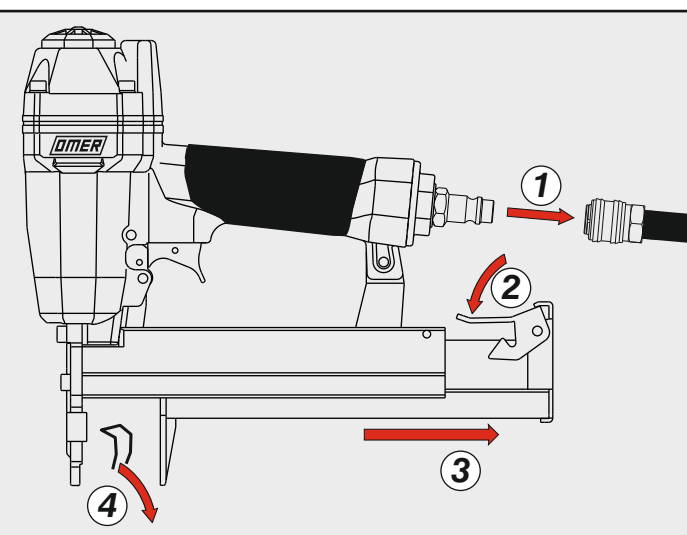

|  |                 |
|--|-----------------|
| <b>Manuale d'uso, manutenzione e parti di ricambio</b>         | <b>Parte 2</b>  |
| <b>Manual for use, maintenance and spare parts</b>             | <b>Part 2</b>   |
| <b>Bedienungs- und Wartungshandbuch sowie Ersatzteilleiste</b> | <b>Teil 2</b>   |
| <b>Mode d'emploi, de maintenance et pièces de rechange</b>     | <b>Partie 2</b> |
| <b>Manual de uso, mantenimiento y recambios</b>                | <b>Part 2</b>   |
| <b>Εγχειρίδιο χρήσης, συντήρησης και ανταλλακτικών</b>         | <b>Μέρος 2</b>  |
| <b>Manual de uso, manutenção e peças sobresselentes</b>        | <b>Parte 2</b>  |
| <b>Handleiding voor gebruik, onderhoud en wisselstukken</b>    | <b>Deel 2</b>   |
| <b>Kullanım, bakım ve yedek parça kılavuzu</b>                 | <b>Kısım 2</b>  |



**94.38 BDA**

cod. 1427430DA

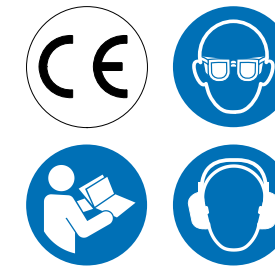

**Warning:** Please read the instructions and warnings for this tool carefully before use. Failure to do so could lead to serious injury.

| Dati tecnici<br>Technical data<br>Technische Daten   | Caractéristiques techniques<br>Datos técnicos<br>Τεχνικά χαρακτηριστικά   | Dados técnicos<br>Technische gegevens<br>Teknik verier  |   |
|--|---|---|---|
| <b>Misure impiegabili mm</b><br>Lengths mm<br>Verwendbare Nagellänge mm  | Dimensions utiles mm<br>Medidas de longitud mm<br>Μήκος Αναλωσίμου - mm   | Medidas utilizáveis mm<br>Toepasbare afmetingen mm<br>Boy mm  | <b>15÷40</b>  |
| <b>Capacità caricatore n° punti</b><br>Magazine capacity<br>Magazinkapazität Nägel   | Capacité chargeur n° de points<br>Capacidad cargador n° puntos<br>Δωνατοτητα γεμιστερα                                | Capacidade carregador n° pontos<br>Capaciteit magazijn in aantal spijkers<br>Dergi kapasitesi                   | <b>105</b>  |
| <b>Pressione d'esercizio</b><br>Operating pressure<br>Betriebsdruck  | Pression d'exercice<br>Presión de servicio<br>Πίεση λειτουργίας   | Pressão de serviço<br>Werkdruk<br>Çalışma basıncı   | <b>5÷7,5 bar<br/>70÷105 psi</b>                         |
| <b>Consumo aria litri/colpo</b><br>Air consumption litres/stroke<br>Luftverbrauch Liter/Schuss   | Consumation d'air litres/coup<br>Consumo aire litros/golpe<br>Κατανάλωση αέρα - λίτρα/βολή                            | Consumo ar litros/disparo<br>Luchtverbruik liter/slag<br>Litre/vuruş hava tüketimi                              | <b>0,54</b>   |
| <b>Peso kg</b><br>Weight kg<br>Gewicht kg  | Poids kg<br>Peso kg<br>Βάρος - kg   | Peso kg<br>Gewicht in kg<br>Ağırlık kg  | <b>1,50</b>   |
| <b>Dimensioni mm</b><br>Dimensions mm<br>Abmessungen mm  | Dimensions mm<br>Dimensiones mm<br>Διαστάσεις mm  | Dimensões mm<br>Afmetingen mm<br>Boyutlar mm  | <b>242x58x245</b><br>(LxWxH)                            |
| <b>UNI EN 12549 :2009</b> <b>UNI EN ISO 4871 :2009</b><br><b>Pressione sonora in pos. operatore</b><br>Sound pressure in operator's position<br>Schalldruck am Arbeitsplatz                                  | Pression sonore poste Opérateur<br>Presión sonora en la pos. del operador<br>Ηχητική πίεση στη θέση του Χειριστή      | Pressão sonora na posição Operador<br>Geluidsdruk op de werkplaats<br>Operatör pozisyonunda ses basıncı         | <b>86 dB(A)</b><br>(K= 4 dB)                            |
| <b>UNI EN 12549 :2009</b> <b>UNI EN ISO 3746 :2011</b> <b>UNI EN ISO 4871 :2009</b><br><b>Potenza sonora emessa</b><br>Sound power emitted<br>Emittierte Schallleistung                                      | Puissance sonore émise<br>Potencia sonora emitida<br>Εκπεμπόμενη ηχητική ισχύς  | Potência sonora emitida<br>Geëmitteerd geluidsvermogen<br>Çıkan ses gücü (ses desibel)                          | <b>94 dB(A)</b><br>(K= 4 dB)                            |
| <b>UNI CEN ISO/TS 8662-11 :2006</b> <b>UNI EN ISO 5349-2 :2004</b> <b>UNI EN 12096 :1999</b><br><b>Emissione vibratoria sull'impugnatura</b><br>Vibratory emissions on handle<br>Vibrationsemission am Griff | Émission vibratoire sur la prise en main<br>Emisión de vibraciones en la empuñadura<br>Εκπεμπόμενες δονήσεις στη λαβή | Emissão vibratória na empunhadura<br>Trillingsemissie op de handgreep<br>Tutamaç üzerinde vibrasyon emisyonları | <b>3,10 m/s<sup>2</sup></b><br>(K= 2 m/s <sup>2</sup> ) |

**Tipo di punto**  
Type of fastener  
Befestigungsmittel  
Type de rivet  
Tipo de punto  
Τύπος αναλωσίμου  
Tipo de agrafa  
Type nietjes  
Zimba ve çivi tipleri

**94**

1,00x1,25

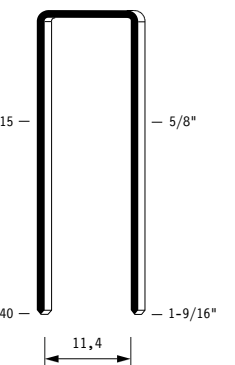

Crown: .528" (17/32")  
Gauge: 18

Parti di ricambio - Spare parts - Ersatzteile - Pièces de rechange - Recambios  
Ανταλλακτικά - Partes sobresselentes - Wisselstukken - Yedek parçalar

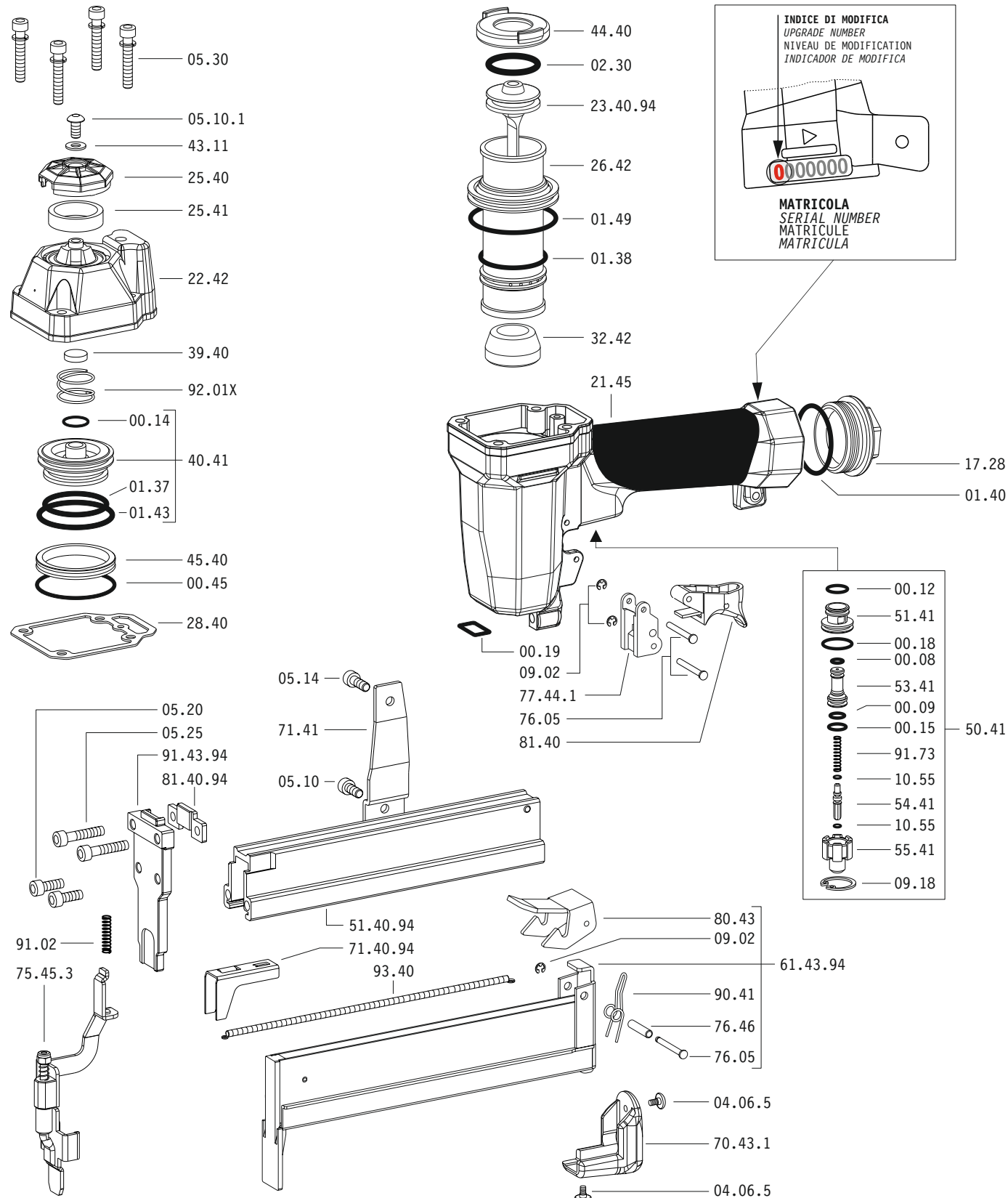

Dotazioni - Equipment - Ausstattung - Outillage - Dotaciones - Εξοπλισμός  
Dotações - Uitrusting - Donanımlar

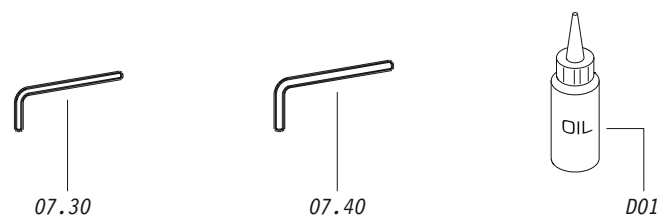

**94.38 BDA**

cod. 1427430DA

Parti di ricambio - Spare parts - Ersatzteile - Pièces de rechange - Recambios  
Ανταλλακτικά - Partes sobresselentes - Wisselstukken - Yedek parçalar

| Cod.     | Descrizione          | Description           |
|----------|----------------------|-----------------------|
| 00.08    | O-Ring               | O-Ring                |
| 00.09    | O-Ring               | O-Ring                |
| 00.12    | O-Ring               | O-Ring                |
| 00.14    | O-Ring               | O-Ring                |
| 00.15    | O-Ring               | O-Ring                |
| 00.18    | O-Ring               | O-Ring                |
| 00.19    | O-Ring               | O-Ring                |
| 00.45    | O-Ring               | O-Ring                |
| 01.37    | O-Ring               | O-Ring                |
| 01.38    | O-Ring               | O-Ring                |
| 01.40    | O-Ring               | O-Ring                |
| 01.43    | O-Ring               | O-Ring                |
| 01.49    | O-Ring               | O-Ring                |
| 02.30    | O-Ring               | O-Ring                |
| 04.06.5  | Vite                 | Screw                 |
| 05.10    | Vite                 | Screw                 |
| 05.10.1  | Vite                 | Screw                 |
| 05.14    | Vite                 | Screw                 |
| 05.20    | Vite                 | Screw                 |
| 05.25    | Vite                 | Screw                 |
| 05.30    | Vite                 | Screw                 |
| 07.30    | Chiave esagonale     | Hex. bar wrench       |
| 07.40    | Chiave esagonale     | Hex. bar wrench       |
| 09.02    | Anello elastico      | Elastic ring          |
| 09.18    | Anello elastico      | Elastic ring          |
| 10.55    | O-Ring               | O-Ring                |
| 17.28    | Tappo                | Inlet cap             |
| 21.45    | Corpo                | Body                  |
| 22.42    | Testa                | Head                  |
| 25.40    | Deflettore           | Exhaust deflector     |
| 25.41    | Silenziatore         | Silencer              |
| 26.42    | Cilindro             | Cylinder              |
| 28.40    | Guarnizione testa    | Head gasket           |
| 32.42    | Ammortizzatore       | Bumper                |
| 39.40    | Guarnizione scarico  | Exhaust seal          |
| 40.41    | Valvola completa     | Valve ass'y           |
| 43.11    | Rondella             | Washer                |
| 44.40    | Guarnizione          | Gasket                |
| 45.40    | Anello valvola       | Ring                  |
| 50.41    | Pulsante completo    | Trigger valve ass'y   |
| 51.41    | Boccola pulsante     | Trigger valve housing |
| 53.41    | Pistone servovalvola | Valve piston          |
| 54.41    | Pulsante             | Trigger valve         |
| 55.41    | Raccordo pulsante    | Bush                  |
| 70.43.1  | Protezione           | Guard                 |
| 71.41    | Reggicaricatore      | Support               |
| 75.45.3  | Sicura               | Safety                |
| 76.05    | Perno                | Pin                   |
| 76.46    | Perno molla          | Pin                   |
| 77.44.1  | Guida sicura         | Safety guide          |
| 80.43    | Grilletto chiusura   | Trigger               |
| 81.40    | Grilletto comando    | Trigger               |
| 90.41    | Molla                | Spring                |
| 91.02    | Molla                | Spring                |
| 91.73    | Molla                | Spring                |
| 92.01X   | Molla                | Spring                |
| 93.40    | Molla                | Spring                |
| 23.40.94 | Battente             | Driver                |
| 51.40.94 | Caricatore           | Magazine              |
| 61.43.94 | Carrello             | Slider                |
| 71.40.94 | Spingipunto          | Pusher                |
| 81.40.94 | Controtestina        | Nose                  |
| 91.43.94 | Testina              | Nose plate            |
| D01      | Bocchetta olio       | Oiler                 |

Guarnizioni - O-Rings - Dichtungen - Joints toriques - Juntas - Δακτύλιος στεγανοποίησης - Vedantes - O-ringen - Contalar

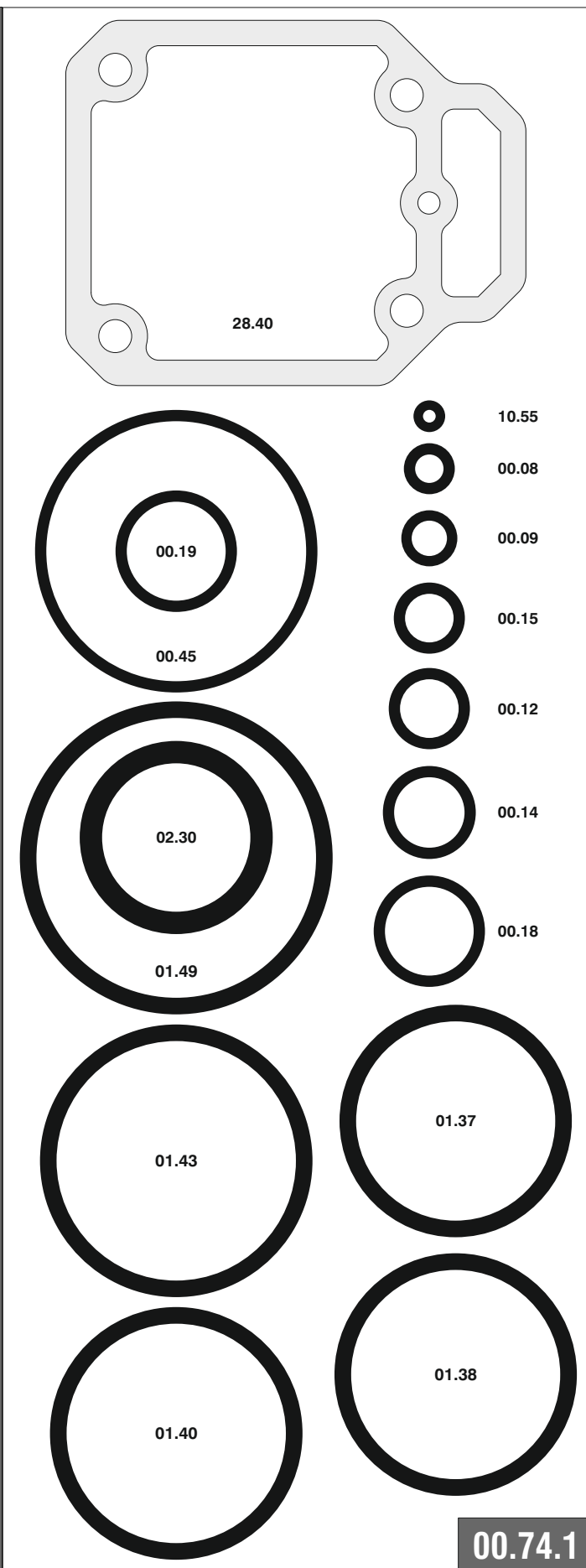

**94.38 BDA**

cod. 1427430DA

Indice di modifica  
Upgrade number

**2**