

Azionamento a contatto continuo
Continual contact actuation

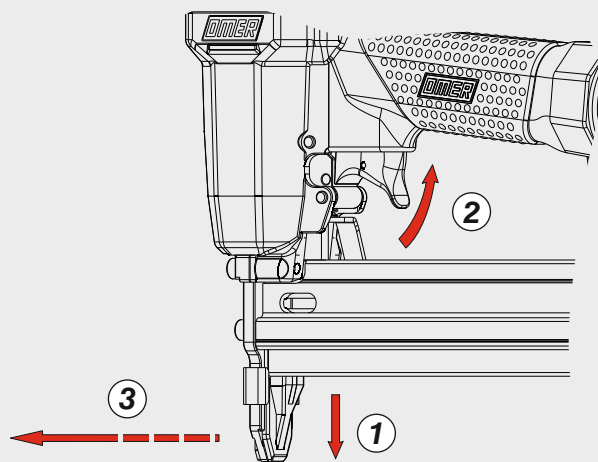

Regolazione della velocità
Speed adjustment

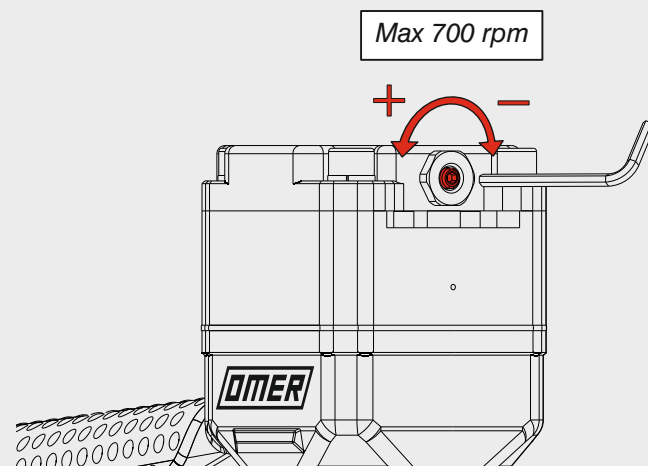

Caricamento - Loading - Laden - Chargement - Carga - Γέμισμα - Carregamento - Laden - Yükleme

Caricamento da sotto
Bottom load magazine

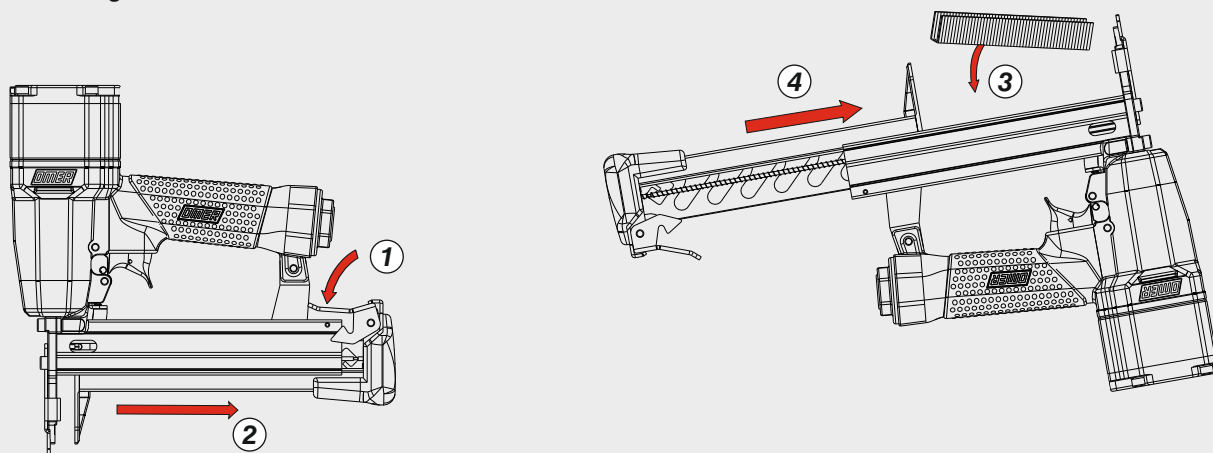

Disinceppamento - Jam clearing - Staubeseitigung - Décoincement - Desatascamiento - Απεμπλοκή
Desencravamento - Deblokkering bij vastlopen - Sıkışma giderme

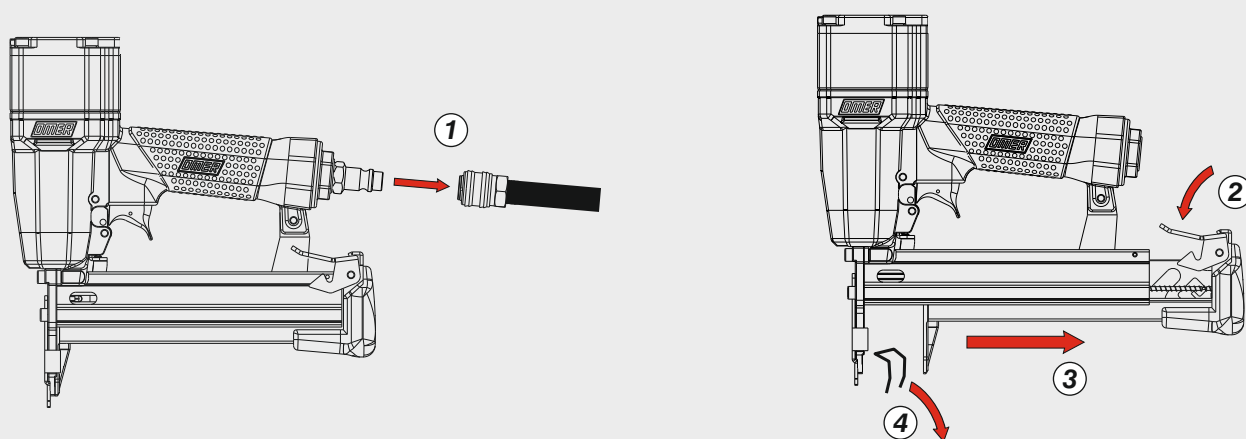

Manuale d'uso, manutenzione e parti di ricambio	Parte 2
Manual for use, maintenance and spare parts	Part 2
Bedienungs- und Wartungshandbuch sowie Ersatzteilleiste	Teil 2
Mode d'emploi, de maintenance et pièces de rechange	Partie 2
Manual de uso, mantenimiento y recambios	Part 2
Εγχειρίδιο χρήσης, συντήρησης και ανταλλακτικών	Μέρος 2
Manual de uso, manutenção e peças sobresselentes	Parte 2
Handleiding voor gebruik, onderhoud en wisselstukken	Deel 2
Kullanım, bakım ve yedek parça kılavuzu	Kısım 2



90.38 BV

cod. 14370380



Warning: Please read the instructions and warnings for this tool carefully before use. Failure to do so could lead to serious injury.

Dati tecnici Technical data Technische Daten	Caractéristiques techniques Datos técnicos Τεχνικά χαρακτηριστικά	Dados técnicos Technische gegevens Teknik verier	
Misure impiegabili mm Lengths mm Verwendbare Nagellänge mm	Dimensions utiles mm Medidas de longitud mm Μήκος Αναλωσίμου - mm	Medidas utilizáveis mm Toepasbare afmetingen mm Boy mm	15 ÷ 40
Capacità caricatore n° punti Magazine capacity Magazinkapazität Nägel	Capacité chargeur n° de points Capacidad cargador n° puntos Δωνατοτητα γεμιστερα	Capacidade carregador n° pontos Capaciteit magazijn in aantal spijkers Dergi kapasitesi	105
Pressione d'esercizio Operating pressure Betriebsdruck	Pression d'exercice Presión de servicio Πίεση λειτουργίας	Pressão de serviço Werkdruk Çalışma basıncı	5 ÷ 7,5 bar 70 ÷ 105 psi
Consumo aria litri/colpo Air consumption litres/stroke Luftverbrauch Liter/Schuss	Consommation d'air litres/coup Consumo aire litros/golpe Κατανάλωση αέρα - λίτρα/βολή	Consumo ar litros/disparo Luchtverbruik liter/slag Litre/vuruş hava tüketimi	0,54
Peso kg Weight kg Gewicht kg	Poids kg Peso kg Βάρος - kg	Peso kg Gewicht in kg Ağırlık kg	1,70
Dimensioni mm Dimensions mm Abmessungen mm	Dimensions mm Dimensiones mm Διαστάσεις mm	Dimensões mm Afmetingen mm Boyutlar mm	242x58x245 (LxWxH)
UNI EN 12549 :2009 UNI EN ISO 4871 :2009	Pressione sonora in pos. operatore Sound pressure in operator's position Schalldruck am Arbeitsplatz	Pressão sonora na posição Operador Geluidsdruk op de werkplaats Operatör pozisyonunda ses basıncı	92 dB(A) (K= 4 dB)
UNI EN 12549 :2009 UNI EN ISO 3746 :2011 UNI EN ISO 4871 :2009	Potenza sonora emessa Sound power emitted Emittierte Schallleistung	Potência sonora emitida Geëmitteerd geluidsvermogen Çıkan ses gücü (ses desibel)	98 dB(A) (K= 4 dB)
UNI CEN ISO/TS 8662-11 :2006 UNI EN ISO 5349-2 :2004 UNI EN 12096 :1999	Emissione vibratoria sull'impugnatura Vibratory emissions on handle Vibrationsemission am Griff	Emissão vibratória na empunhadura Trillingsemissie op de handgreep Tutamak üzerindeki vibrasyon emisyonları	3,13 m/s² (K= 2 m/s ²)

Tipo di punto
Type of fastener
Befestigungsmittel
Tipo de rivet
Tipo de punto
Τύπος αναλωσίμου
Tipo de agrafa
Type nietjes
Zimba ve çivi tipleri

90

☑ 1,00x1,25

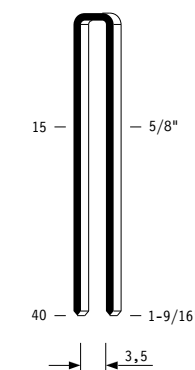

Crown: .217" (1/4")
Gauge: 18

Parti di ricambio - Spare parts - Ersatzteile - Pièces de rechange - Recambios
Ανταλλακτικά - Partes sobresselentes - Wisselstukken - Yedek parçalar

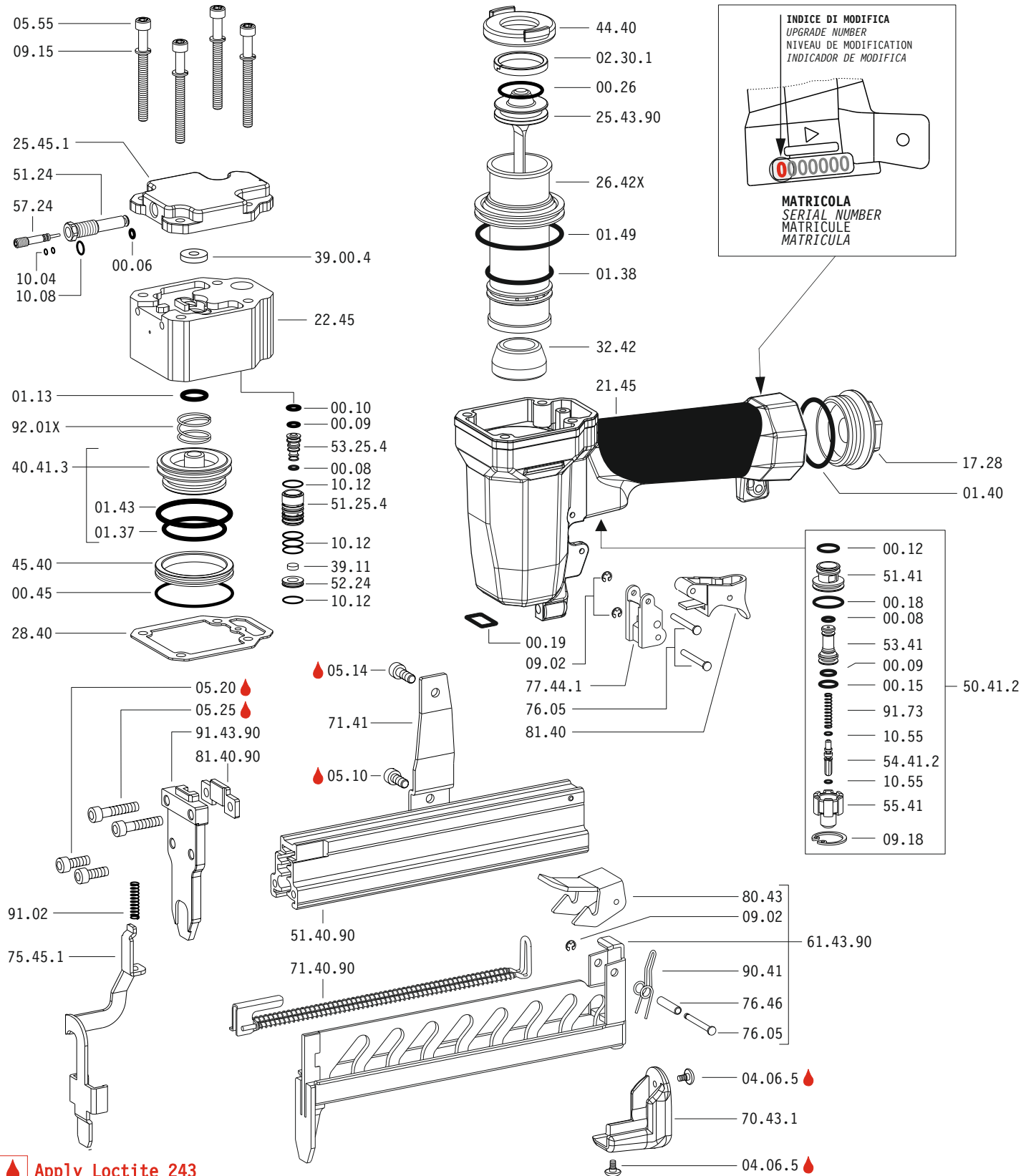

Apply Loctite 243

Dotazioni - Equipment - Ausstattung - Outillage - Dotaciones - Εξοπλισμός
Dotações - Uitrusting - Donanımlar

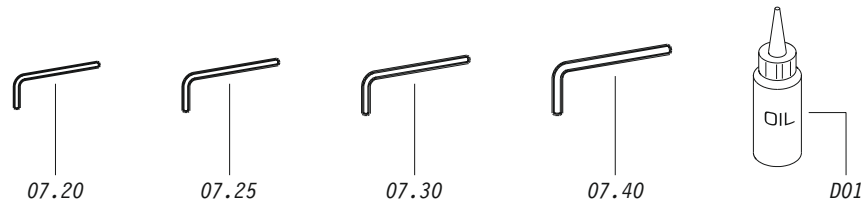

90.38 BV

cod. 14370380

Parti di ricambio - Spare parts - Ersatzteile - Pièces de rechange - Recambios
Ανταλλακτικά - Partes sobresselentes - Wisselstukken - Yedek parçalar

Cod.	Descrizione	Description
00.06	O-Ring	O-Ring
00.08	O-Ring	O-Ring
00.09	O-Ring	O-Ring
00.10	O-Ring	O-Ring
00.12	O-Ring	O-Ring
00.15	O-Ring	O-Ring
00.18	O-Ring	O-Ring
00.19	O-Ring	O-Ring
00.26	O-Ring	O-Ring
00.45	O-Ring	O-Ring
01.13	O-Ring	O-Ring
01.37	O-Ring	O-Ring
01.38	O-Ring	O-Ring
01.40	O-Ring	O-Ring
01.43	O-Ring	O-Ring
01.49	O-Ring	O-Ring
02.30.1	Guarnizione	Gasket
04.06.5	Vite	Screw
05.10	Vite	Screw
05.14	Vite	Screw
05.20	Vite	Screw
05.25	Vite	Screw
05.55	Vite	Screw
07.20	Chiave esagonale	Hex. bar wrench
07.25	Chiave esagonale	Hex. bar wrench
07.30	Chiave esagonale	Hex. bar wrench
07.40	Chiave esagonale	Hex. bar wrench
09.02	Anello elastico	Elastic ring
09.15	Rondella	Washer
09.18	Anello elastico	Elastic ring
10.04	O-Ring	O-Ring
10.08	O-Ring	O-Ring
10.12	O-Ring	O-Ring
10.55	O-Ring	O-Ring
12.10.1	Spina	Pin
17.28	Tappo	Inlet cap
21.45	Corpo	Body
22.45	Testa	Head
25.45.1	Deflettore	Exhaust deflector
26.42X	Cilindro	Cylinder
28.40	Guarnizione testa	Head gasket
32.42	Ammortizzatore	Bumper
39.00.4	Guarnizione	Seal
39.11	Guarnizione	Seal
40.41.3	Valvola completa	Valve ass'y
44.40	Guarnizione	Gasket
45.40	Anello valvola	Ring
50.41.2	Pulsante completo	Trigger valve ass'y
51.24	Boccola regolatore	Regulator valve housing
51.25.4	Cilindro servovalvola	Valve cylinder
51.41	Boccola pulsante	Trigger valve housing
52.24	Tappo	Stopper
53.25.4	Pistone servovalvola	Valve piston
53.41	Pistone servovalvola	Valve piston
54.41.2	Pulsante	Trigger valve
55.41	Raccordo pulsante	Bush
57.24	Regolatore	Regulator
70.43.1	Protezione	Guard
71.41	Reggicaricatore	Support
75.45.1	Sicura	Safety
76.05	Perno	Pin
76.46	Perno molla	Pin
77.44.1	Guida sicura	Safety guide
80.43	Grilletto chiusura	Trigger
81.40	Grilletto comando	Trigger
90.41	Molla	Spring
91.02	Molla	Spring
91.73	Molla	Spring
92.01X	Molla	Spring
25.43.90	Battente	Driver
51.40.90	Caricatore	Magazine
61.43.90	Carrello	Slider
71.40.90	Spingipunto	Pusher
81.40.90	Controtestina	Nose
91.43.90	Testina	Nose plate
D01	Bocchetta olio	Oiler

90.38 BV

cod. 14370380

Guarnizioni - O-Rings - Dichtungen - Joints toriques - Junta - Δακτύλιος στεγανοποίησης - Vedantes - O-ringen - Contalar

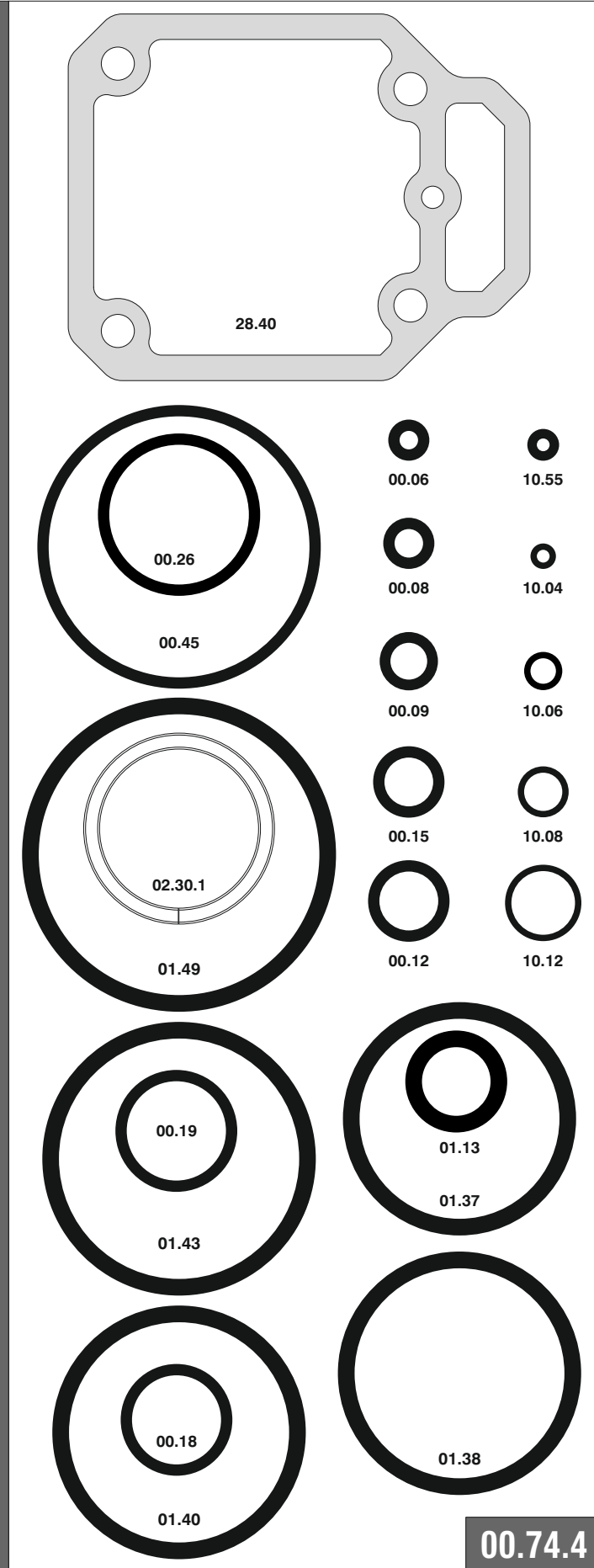

Indice di modifica
Upgrade number

3