

Azionamento sequenziale singolo
 Single sequential actuation

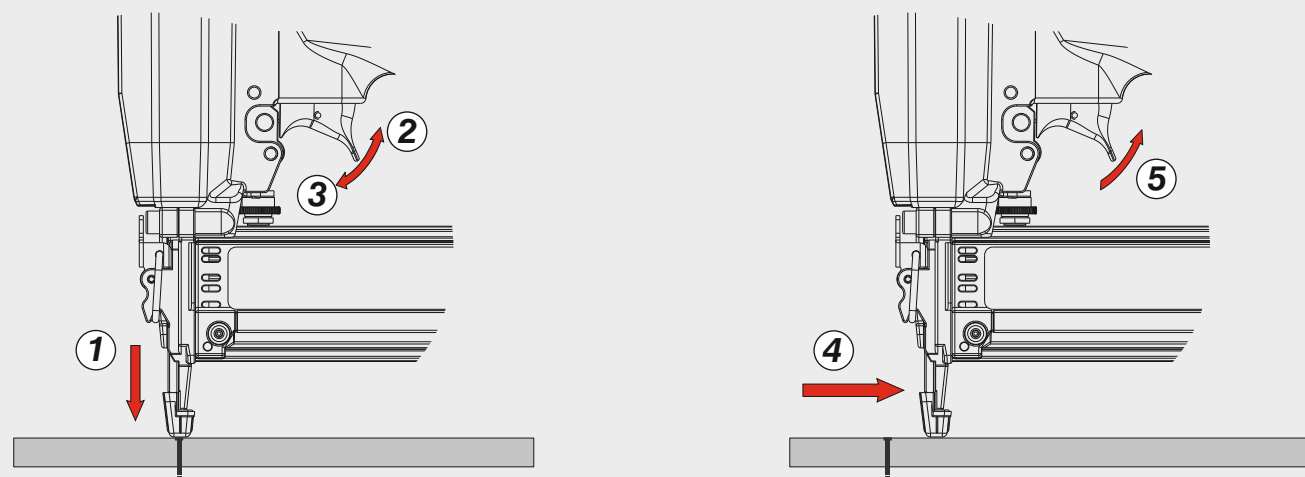

Caricamento - Loading - Laden - Chargement - Carga - Γέμισμα - Carregamento - Laden - Yükleme - Laddning

Caricamento dal fianco
 Side load magazine

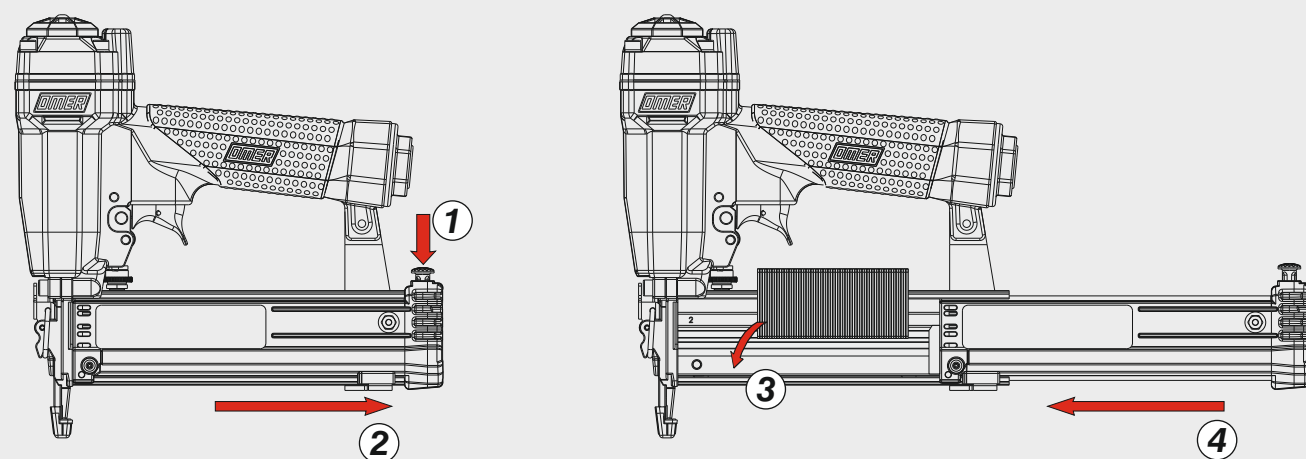

Regolazione di profondità - Depth adjustment - Tiefeneinstellung - Réglage des dimensions - Réglage des dimensions
 Ρύθμιση βάθους - Regulação de profundidade - Diepte afstelling - Derinlik ayarı - Djupjustering

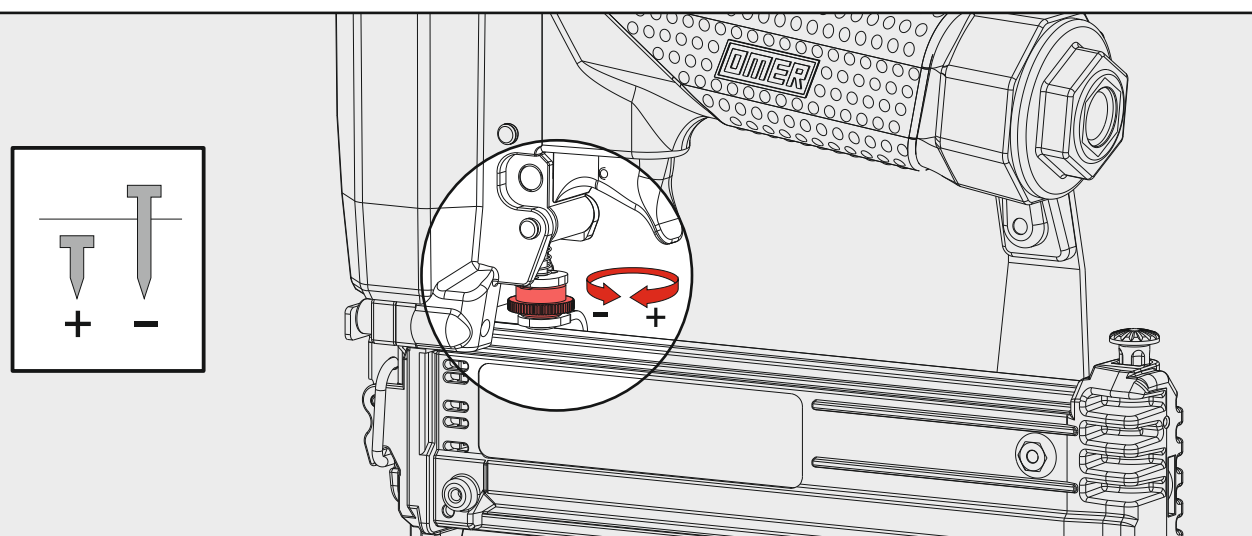

Manuale d'uso, manutenzione e parti di ricambio	Parte 2
Manual for use, maintenance and spare parts	Part 2
Bedienungs- und Wartungshandbuch sowie Ersatzteilliste	Teil 2
Mode d'emploi, de maintenance et pièces de rechange	Partie 2
Manual de uso, mantenimiento y recambios	Part 2
Εγχειρίδιο χρήσης, συντήρησης και ανταλλακτικών	Μέρος 2
Manual de uso, manutenção e peças sobresselentes	Parte 2
Handleiding voor gebruik, onderhoud en wisselstukken	Deel 2
Kullanım, bakım ve yedek parça kılavuzu	Kısım 2
Användar-, underhålls- och reservdelshandbok	Del 2



14.50

cod. 14214110



Dati tecnici Technical data Technische Daten Tekniska data	Caractéristiques techniques Datos técnicos Τεχνικά χαρακτηριστικά	Dados técnicos Technische gegevens Teknik veriler
Misure impiegabili Lengths Verwendbare Nagellänge Dimensioner som kan användas	Dimensions utiles Medidas de longitud Μήκος Αναλωσίμου	Medidas utilizáveis Toepasbare afmetingen Boy
Capacità caricatore n° punti Magazine capacity Magazinkapazität Magasinkapacitet Antal punkter	Capacité chargeur n° de points Capacidad cargador n° puntos Δυνατότητα γεμιστέρα	Capacidade carregador n° pontos Capaciteit magazijn in aantal spijkers Dergi kapasitesi
Pressione d'esercizio Operating pressure Betriebsdruck Drifttryck	Pression d'exercice Presión de servicio Πίεση λειτουργίας	Pressão de serviço Werkdruk Çalışma basıncı
Consumo aria Air consumption Luftverbrauch Luftförbrukning	Consommation d'air Consumo aire Κατανάλωση αέρα	Consumo ar Luchtverbruik Hava tüketimi
Peso Weight Gewicht Vikt	Poids Peso Βάρος	Peso Gewicht Ağırlık
Dimensioni Dimensions Abmessungen Dimensioner (AxBxH)	Dimensions Dimensiones Διαστάσεις	Dimensões Afmetingen Boyutlar
EN 12549 :2009 EN ISO 4871 :2009 Pressione sonora in pos. operatore Sound pressure in operator's position Schalldruck am Arbeitsplatz Ljudtryck på operatörsplatsen	Pression sonore poste Opérateur Presión sonora en la pos. del operador Ηχητική πίεση στη θέση του χειριστή	Pressão sonora na posição Operador Geluidsdruk op de werkplaats Operatör pozisyonunda ses basıncı
EN 12549 :2009 EN ISO 3746 :2011 EN ISO 4871 :2009 Potenza sonora emessa Sound power emitted Emitierte Schalleistung Avgiven ljudeffekt	Puissance sonore émise Potencia sonora emitida Εκπεμπόμενη ηχητική ισχύς	Potência sonora emitida Geëmitteerd geluidsvermogen Çıkan ses gücü (ses desibel)
CEN ISO/TS 8662-11 :2006 EN ISO 5349-2 :2004 EN 12096 :1999 Emissione vibratoria sull'impugnatura Vibratory emissions on handle Vibrationsemission am Griff Vibrationsemission på handtaget	Émission vibratoire sur la prise en main Emisión de vibraciones en la empuñadura Εκπεμπόμενες δονήσεις στη λαβή	Emissão vibratória na empunhadura Trillingsemissie op de handgreep Tutamak üzerinde vibrasyon emisyonları

Tipo di punto
 Type of fastener
 Befestigungsmittel
 Type de rivet
 Tipo de punto
 Τύπος αναλωσίμου
 Tipo de agrafo
 Type nietjes
 Zimba ve çivi tipleri
 Typ av stygn

Brads 14

1,40x1,60

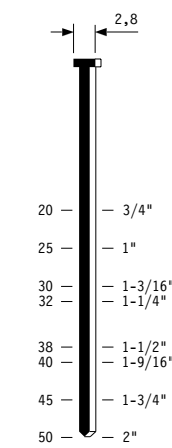

Head width: .108"
 Gauge: 16

Parti di ricambio - Spare parts - Ersatzteile - Pièces de rechange - Recambios
Ανταλλακτικά - Partes sobresselentes - Wisselstukken - Yedek parçalar - Reservdelar

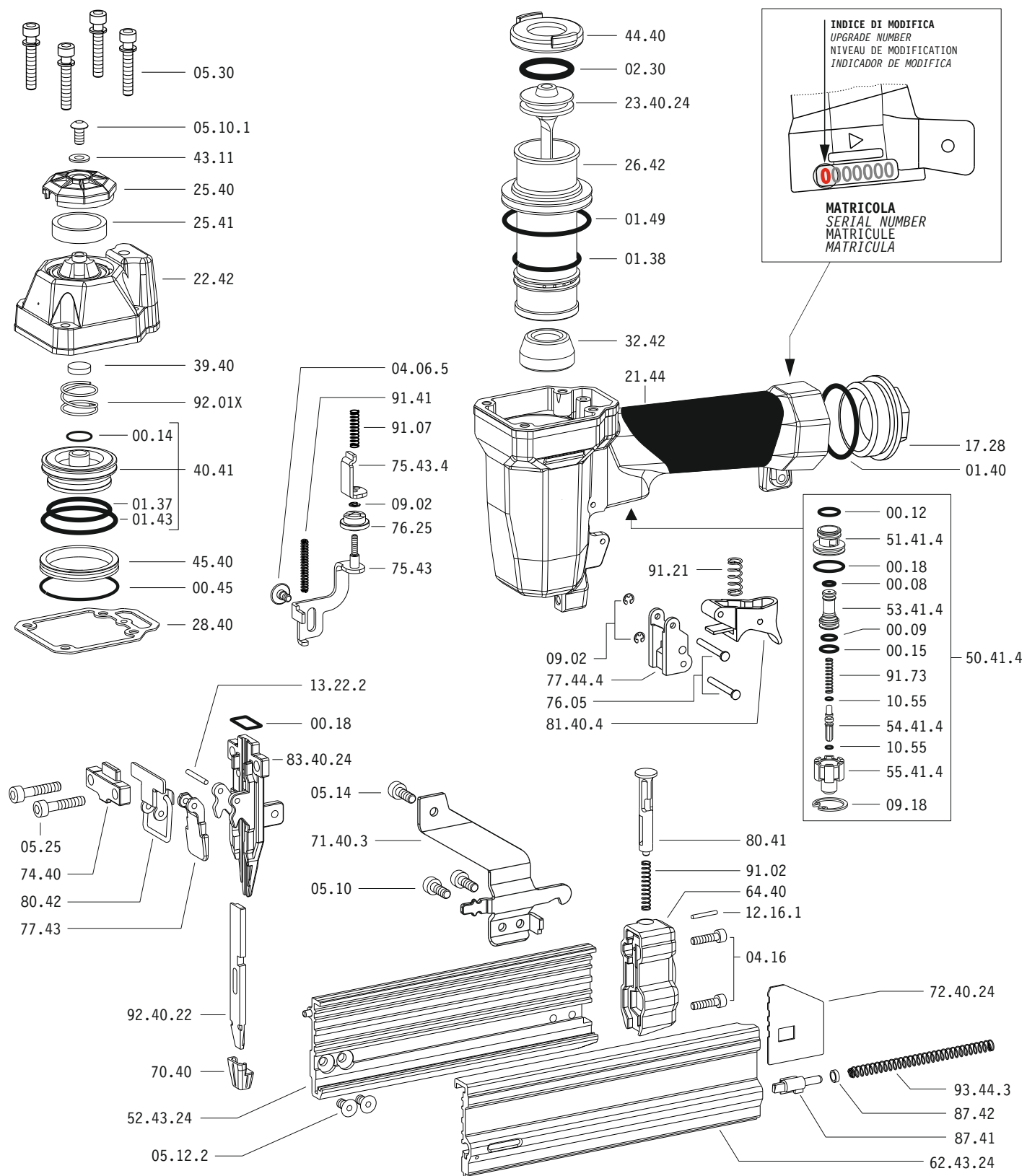

Dotazioni - Equipment - Ausstattung - Outillage - Dotaciones - Εξοπλισμός
Dotações - Uitrusting - Donanımlar - Utrustning

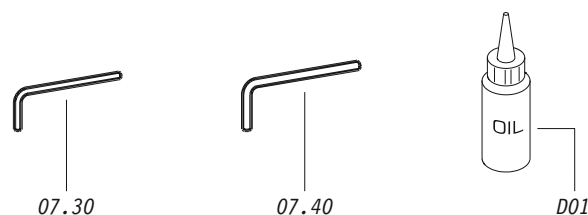

14.50

cod. 14214110

Parti di ricambio - Spare parts - Ersatzteile - Pièces de rechange - Recambios
Ανταλλακτικά - Partes sobresselentes - Wisselstukken - Yedek parçalar - Reservdelar

Cod.	Descrizione	Description
00.08	O-Ring	O-Ring
00.09	O-Ring	O-Ring
00.12	O-Ring	O-Ring
00.14	O-Ring	O-Ring
00.15	O-Ring	O-Ring
00.18	O-Ring	O-Ring
00.45	O-Ring	O-Ring
01.37	O-Ring	O-Ring
01.38	O-Ring	O-Ring
01.40	O-Ring	O-Ring
01.43	O-Ring	O-Ring
01.49	O-Ring	O-Ring
02.30	O-Ring	O-Ring
04.06.5	Vite	Screw
04.16	Vite	Screw
05.10	Vite	Screw
05.10.1	Vite	Screw
05.12.2	Vite	Screw
05.14	Vite	Screw
05.25	Vite	Screw
05.30	Vite	Screw
07.30	Chiave esagonale	Hex. bar wrench
07.40	Chiave esagonale	Hex. bar wrench
09.02	Anello elastico	Elastic ring
09.18	Anello elastico	Elastic ring
10.55	O-Ring	O-Ring
12.16.1	Spina	Pin
13.22.2	Spina	Pin
17.28	Tappo	Inlet cap
21.44	Corpo	Body
22.42	Testa	Head
25.40	Deflettore	Exhaust deflector
25.41	Silenziatore	Silencer
26.42	Cilindro	Cylinder
28.40	Guarnizione testa	Head gasket
32.42	Ammortizzatore	Bumper
39.40	Guarnizione scarico	Exhaust seal
40.41	Valvola completa	Valve ass'y
43.11	Rondella	Washer
44.40	Guarnizione	Gasket
45.40	Anello valvola	Ring
50.41.4	Pulsante completo	Trigger valve ass'y
51.41.4	Boccola pulsante	Trigger valve housing
53.41.4	Pistone servovalvola	Valve piston
54.41.4	Pulsante	Trigger valve
55.41.4	Raccordo pulsante	Bush
64.40	Fondello	Cap
70.40	Puntale	Contact tip
71.40.3	Reggicaricatore	Support
74.40	Staffa testina	Nose guide
75.43	Sicura	Safety
75.43.4	Rinvio sicura	Contact arm
76.05	Perno	Pin
76.25	Regolatore	Adjusting wheel
77.43	Guida testina	Safety nose plate
77.44.4	Guida sicura	Safety guide
80.41	Grilletto chiusura	Magazine lock trigger
80.42	Grilletto testina	Nose plate lock
81.40.4	Grilletto comando	Trigger
87.41	Portamolla	Spring bearing
87.42	Segnalatore	Signal washer
91.02	Molla	Spring
91.07	Molla	Spring
91.21	Molla	Spring
91.41	Molla	Spring
91.73	Molla	Spring
92.01X	Molla	Spring
93.44.3	Molla	Spring
23.40.24	Battente	Driver
52.43.24	Caricatore	Magazine
62.43.24	Carrello	Slider
72.40.24	Spingipunto	Pusher
83.40.24	Controtestina	Nose
92.40.22	Testina	Nose plate
D01	Bocchetta olio	Oiler

14.50

cod. 14214110

Guarnizioni - O-Rings - Dichtungen - Joints toriques - Junta - Δακτύλιος στεγανοποίησης - Vedantes - O-ringen - Contalar - O-ringar

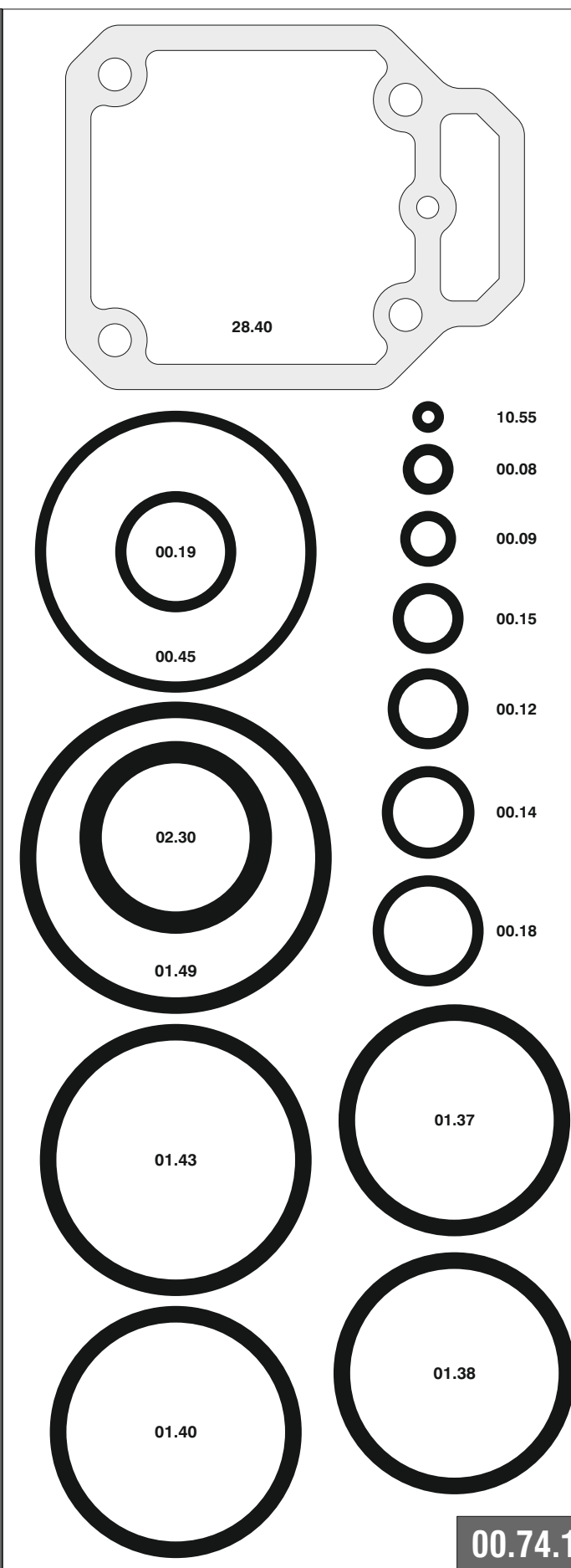

Indice di modifica
Upgrade number

2

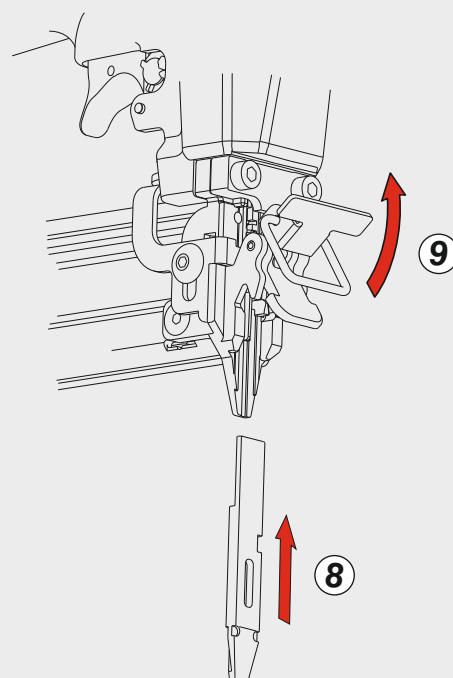
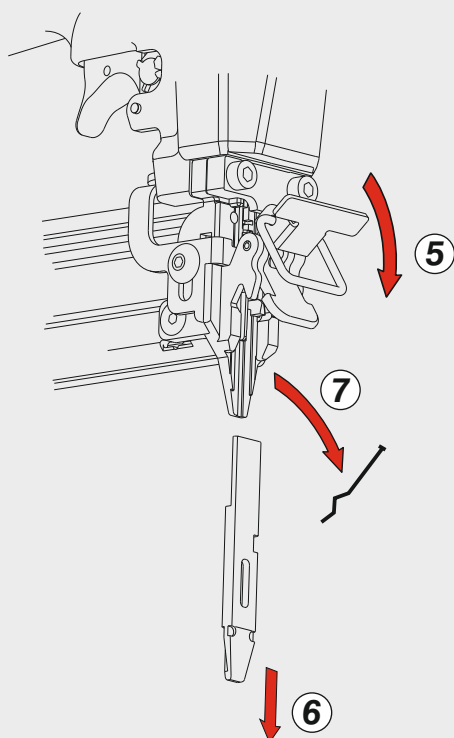
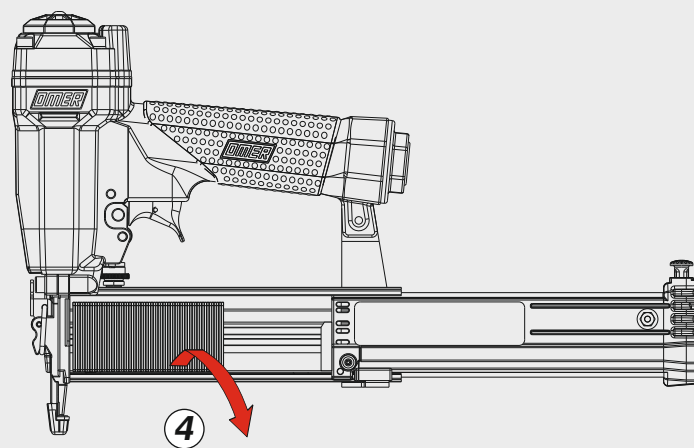
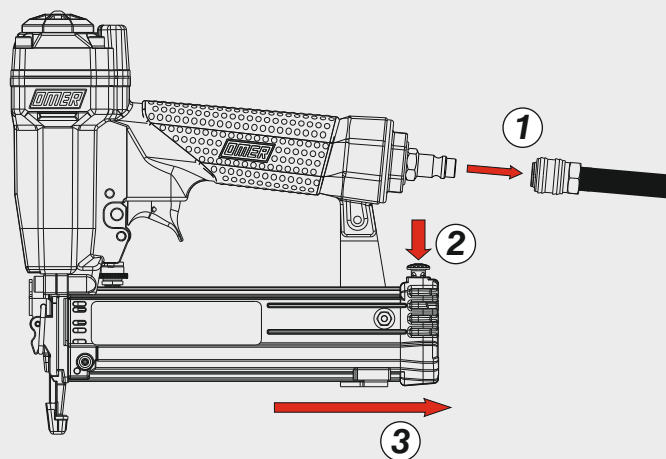

Segnalatore punti rimanenti
Fastener quantity indicator

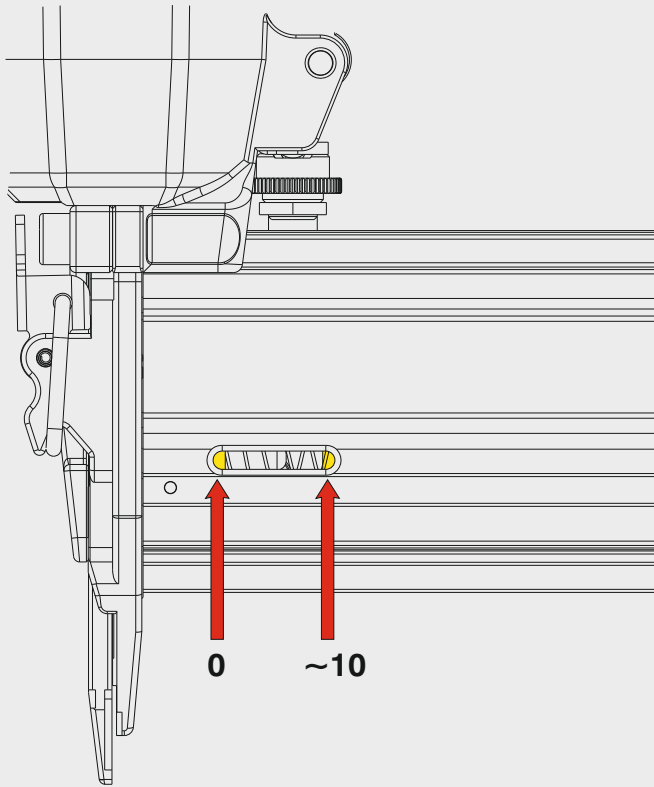

Dispositivo di blocco sparo a fine punti
Stop firing device on empty magazine

