

## Collegamento - Connection

**Collegamento:**  
Connection:

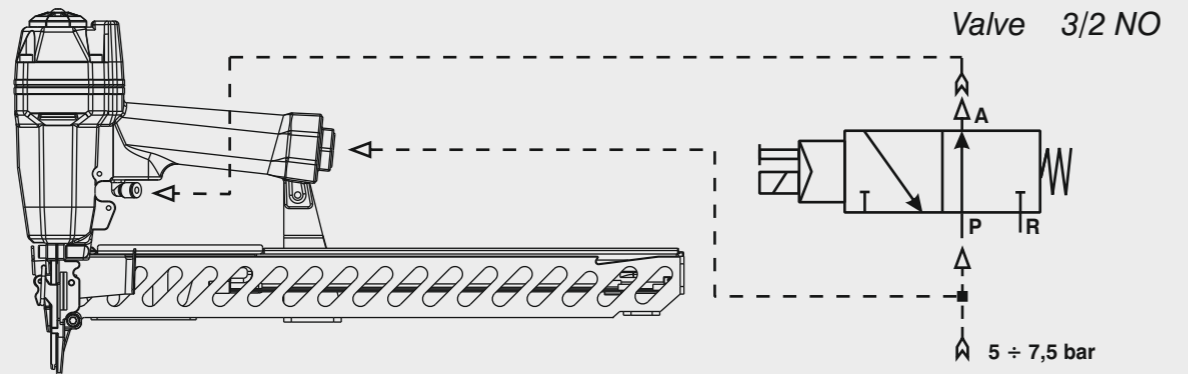

# OMER®

Manuale d'uso, manutenzione e parti di ricambio	Parte 2
Manual for use, maintenance and spare parts	Part 2
Bedienungs- und Wartungshandbuch sowie Ersatzteilleiste	Teil 2
Mode d'emploi, de maintenance et pièces de rechange	Partie 2
Manual de uso, mantenimiento y recambios	Part 2
Εγχειρίδιο χρήσης, συντήρησης και ανταλλακτικών	Μέρος 2
Manual de uso, manutenção e peças sobresselentes	Parte 2
Handleiding voor gebruik, onderhoud en wisselstukken	Deel 2
Kullanım, bakım ve yedek parça kılavuzu	Kısım 2
Användar-, underhålls- och reservdelshandbok	Del 2



Caricamento - Loading - Laden - Chargement - Carga - Γέμισμα - Carregamento - Laden - Yükleme - Laddning

**Caricamento da sopra**  
Top load magazine

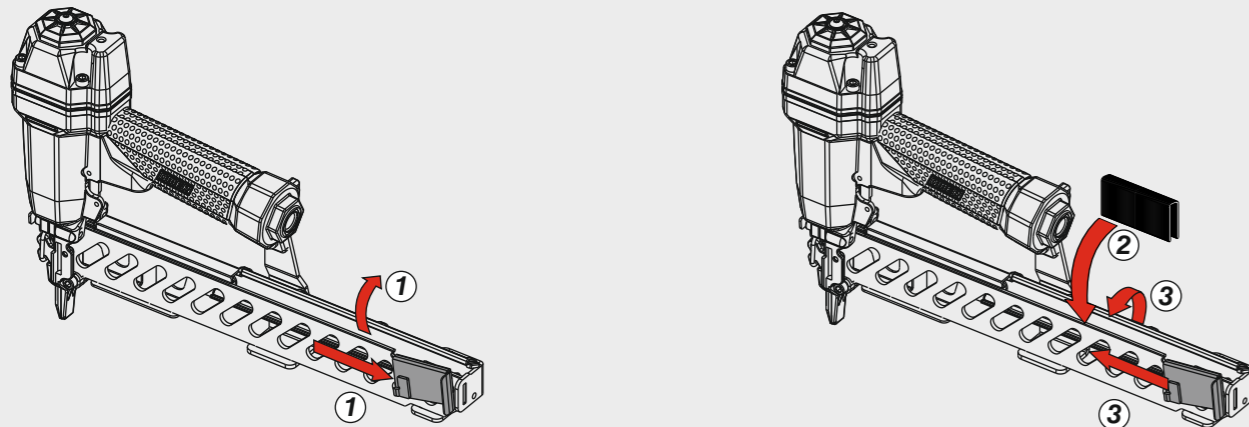

Disincerramento - Jam clearing - Staubeseitigung - Décoincement - Desatascamiento - Απεμπλοκή  
Desencravamento - Deblokkering bij vastlopen - Sıkışma giderme - Rensning av igensättningar

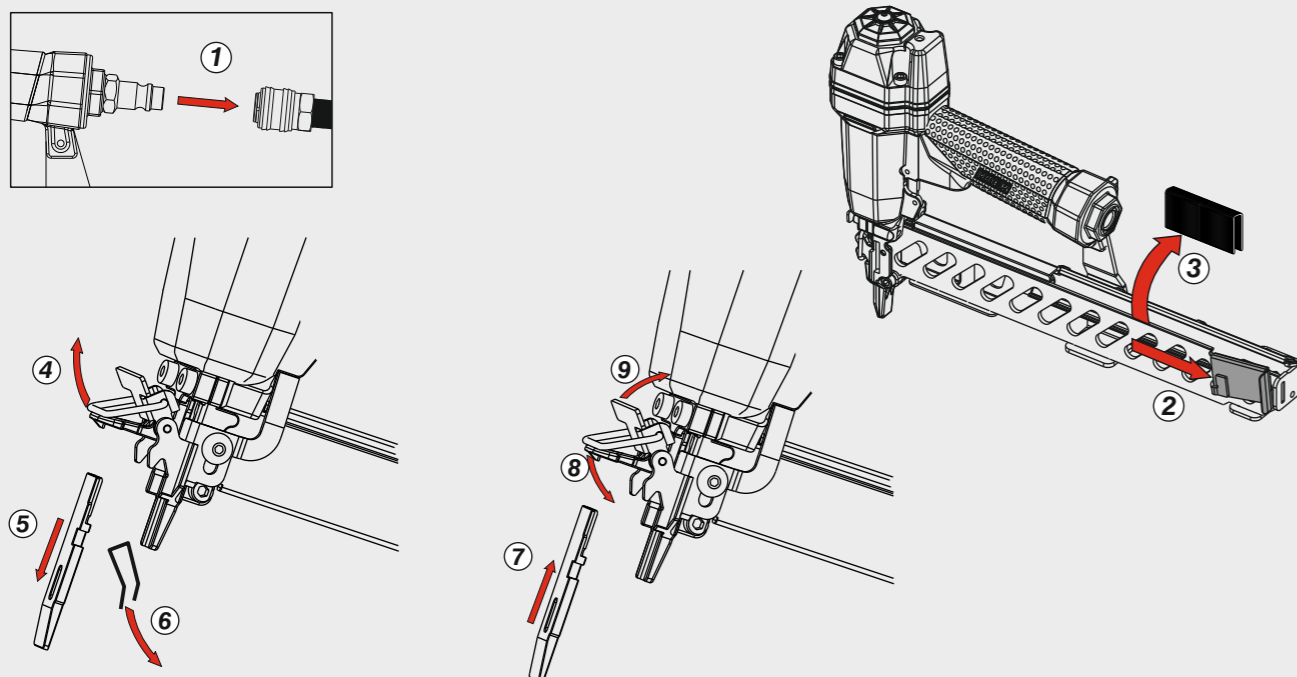

## 90.38 CLD3

cod. 142704530D

### Dati tecnici

Technical data  
Technische Daten  
Tekniska data

Caractéristiques techniques  
Datos técnicos  
Τεχνικά χαρακτηριστικά

Dados técnicos  
Technische gegevens  
Teknik veriler

**Misure impiegabili**  
Lengths  
Verwendbare Nagellänge  
Dimensioner som kan användas

Dimensions utiles  
Medidas de longitud  
Μήκος Αναλωσίμου

Medidas utilizáveis  
Toepasbare afmetingen  
Boy

**15 ÷ 40**

**Capacità caricatore n° punti**  
Magazine capacity  
Magazinkapazität Nägel  
Magasinkapacitet Antal punkter

Capacité chargeur n° de points  
Capacidad cargador n° puntos  
Δυνατότητα γεμιστέρα

Capacidade carregador n° pontos  
Capaciteit magazijn in aantal spijkers  
Dergi kapasitesi

**300**

**Pressione d'esercizio**  
Operating pressure  
Betriebsdruck  
Drifttryck

Pression d'exercice  
Presión de servicio  
Πίεση λειτουργίας

Pressão de serviço  
Werkdruk  
Çalışma basıncı

**5 ÷ 7,5 bar  
70 ÷ 105 psi**

**Consumo aria**  
Air consumption  
Luftverbrauch  
Luftförbrukning

Consommation d'air  
Consumo aire  
Κατανάλωση αέρα

Consumo ar  
Luchtverbruik  
Hava tüketimi

**0,54**

**Peso**  
Weight  
Gewicht  
Vikt

Poids  
Peso  
Βάρος

Peso  
Gewicht  
Ağırlık

**1,60**

**Dimensioni**  
Dimensions  
Abmessungen  
Dimensioner (AxBxH)

Dimensions  
Dimensiones  
Διαστάσεις

Dimensões  
Afmetingen  
Boyutlar

**480x58x241**  
(LxWxH)

EN 12549 :2009 EN ISO 3746 :2011 EN ISO 4871 :2009

**Potenza sonora emessa**  
Sound power emitted  
Emittierte Schalleistung  
Avgiven ljudeffekt

Puissance sonore émise  
Potencia sonora emitida  
Εκπεμπόμενη ηχητική ισχύς

Potência sonora emitida  
Geëmitteerd geluidsvermogen  
Çıkan ses gücü (ses desibel)

**93 dB(A)**

(K = 4 dB)

**Tipo di punto**  
Type of fastener  
Befestigungsmittel  
Type de rivet  
Tipo de punto  
Τύπος αναλωσίμου  
Tipo de agrafó  
Type nietjes  
Zimba ve çivi tipleri  
Typ av stygn

**90**

1,00x1,25

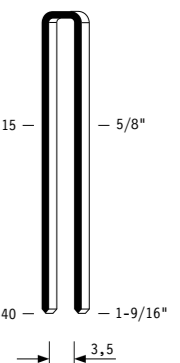

Crown: .217" (1/4")  
Gauge: 18

142704530D\_9038CLD3\_2\_rev21\_19/04/2023\_DV

**DO NOT  
HANDHELD  
THIS TOOL**



Parti di ricambio - Spare parts - Ersatzteile - Pièces de rechange - Recambios  
Ανταλλακτικά - Partes sobresselentes - Wisselstukken - Yedek parçalar - Reservdelar

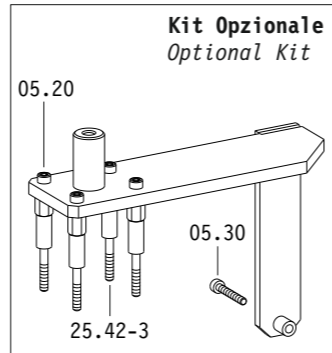
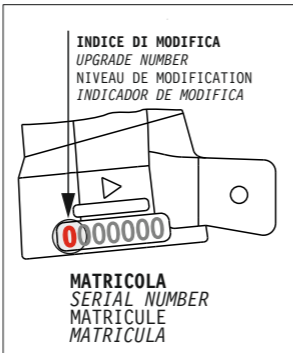
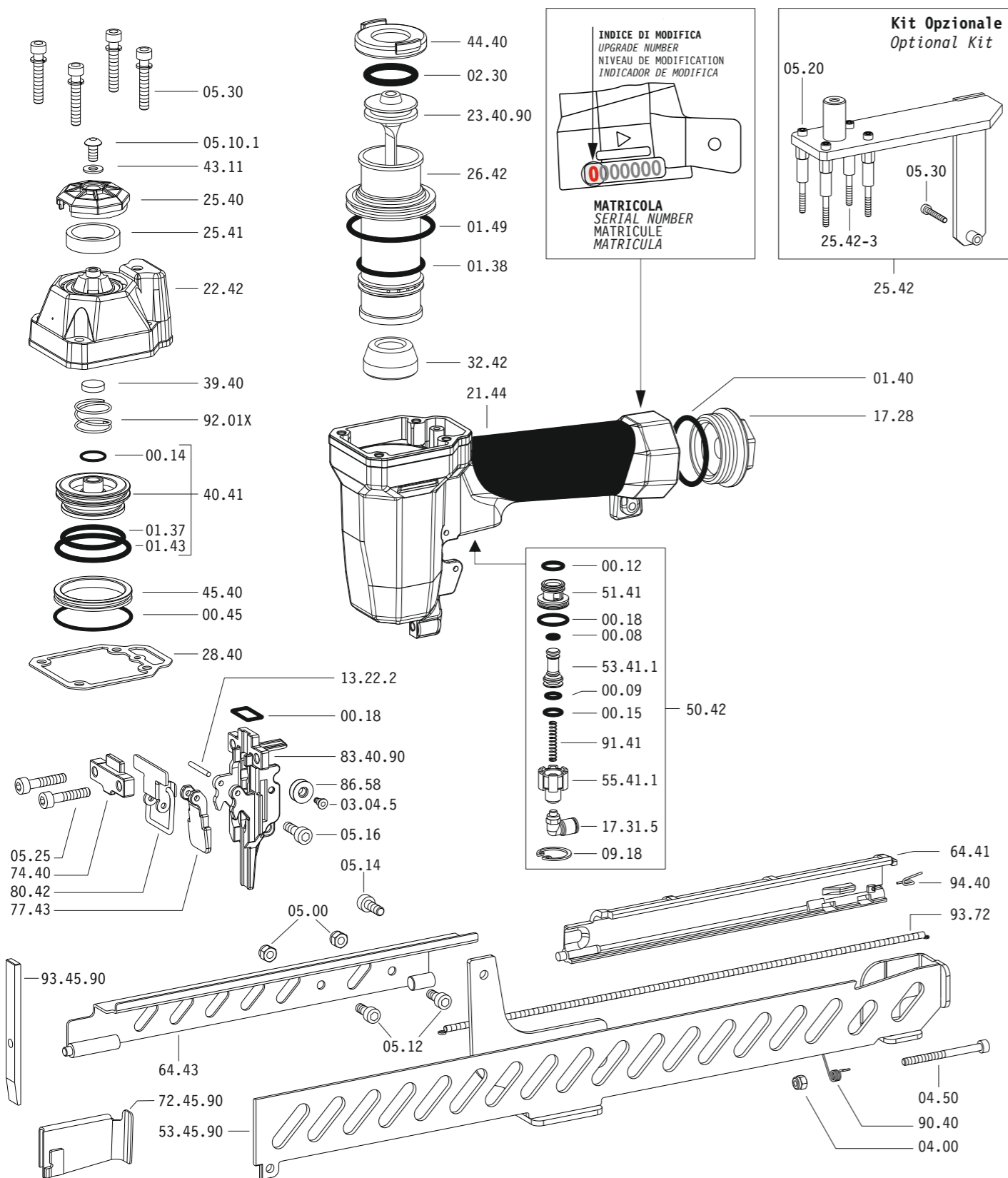

Dotazioni - Equipment - Ausstattung - Outillage - Dotaciones - Εξοπλισμός  
Dotações - Uitrusting - Donanimlar - Utrustning

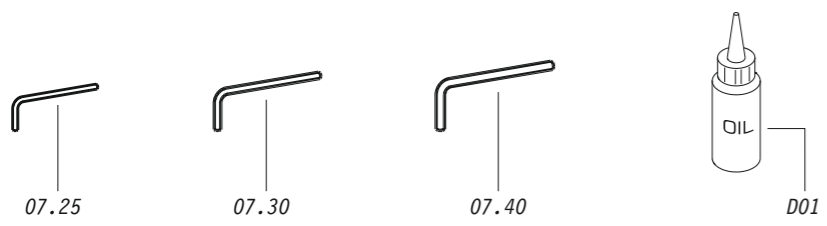

**90.38 CLD3**

cod. 142704530D

Parti di ricambio - Spare parts - Ersatzteile - Pièces de rechange - Recambios  
Ανταλλακτικά - Partes sobresselentes - Wisselstukken - Yedek parçalar - Reservdelar

Cod.	Descrizione	Description
00.08	O-Ring	O-Ring
00.09	O-Ring	O-Ring
00.12	O-Ring	O-Ring
00.14	O-Ring	O-Ring
00.15	O-Ring	O-Ring
00.18	O-Ring	O-Ring
00.45	O-Ring	O-Ring
01.37	O-Ring	O-Ring
01.38	O-Ring	O-Ring
01.40	O-Ring	O-Ring
01.43	O-Ring	O-Ring
01.49	O-Ring	O-Ring
02.30	O-Ring	O-Ring
03.04.5	Vite	Screw
04.00	Dado	Nut
04.50	Vite	Screw
05.00	Dado	Nut
05.10.1	Vite	Screw
05.12	Vite	Screw
05.14	Vite	Screw
05.16	Vite	Screw
05.20	Vite	Screw
05.25	Vite	Screw
05.30	Vite	Screw
07.25	Chiave esagonale	Hex. bar wrench
07.30	Chiave esagonale	Hex. bar wrench
07.40	Chiave esagonale	Hex. bar wrench
09.18	Anello elastico	Elastic ring
13.22.2	Spina	Pin
17.28	Tappo	Inlet cap
17.31.5	Raccordo	Air plug
21.44	Corpo	Body
22.42	Testa	Head
25.40	Deflettore	Exhaust deflector
25.41	Silenziatore	Silencer
25.42	Supporto	Support
25.42-3	Distanziale	Spacer
26.42	Cilindro	Cylinder
28.40	Guarnizione testa	Head gasket
32.42	Ammortizzatore	Bumper
39.40	Guarnizione scarico	Exhaust seal
40.41	Valvola completa	Valve ass'y
43.11	Rondella	Washer
44.40	Guarnizione	Gasket
45.40	Anello valvola	Ring
50.42	Pulsante completo	Trigger valve ass'y
51.41	Boccola pulsante	Trigger valve housing
53.41.1	Pistone servovalvola	Valve piston
55.41.1	Raccordo pulsante	Bush
64.41	Carter	Hold down
64.43	Carter	Hold down
74.40	Staffa testina	Nose guide
77.43	Guida testina	Safety nose plate
80.42	Grilletto testina	Nose plate lock
86.58	Carrucola	Pulley
90.40	Molla	Spring
91.41	Molla	Spring
92.01X	Molla	Spring
93.72	Molla	Spring
94.40	Molla	Spring
23.40.90	Battente	Driver
53.45.90	Caricatore	Magazine
72.45.90	Spingipunto	Pusher
83.40.90	Controtestina	Nose
93.45.90	Testina	Nose plate
D01	Bocchetta olio	Oiler

Guarnizioni - O-Rings - Dichtungen - Joints toriques - Juntas - Δακτύλιος στεγανοποίησης - Vedantes - O-ringen - Contalar - O-ringar

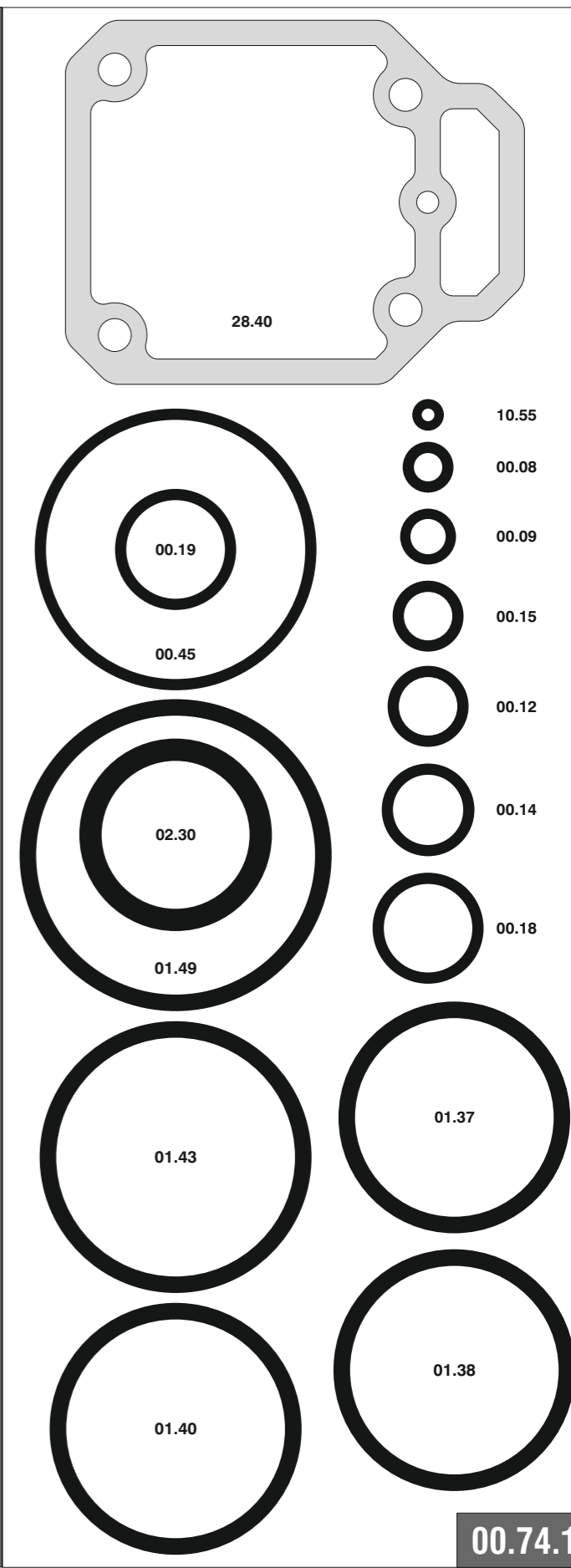

**00.74.1**

**90.38 CLD3**

cod. 142704530D

Indice di modifica  
Upgrade number

**2**