



Manuale d'uso, manutenzione e parti di ricambio
Use, maintenance and spare parts manual
Gebrauchsanweisung, Instandhaltungsrichtlinien und Ersatzteile
Manuel d'utilisation, entretien et pièces de rechange
Manual de uso, mantenimiento y repuestos

Parte 2
Part 2
Teil 2
Partie 2
Part 2

Manual de utilização, manutenção e partes sobresselentes
Handleiding voor gebruik, onderhoud en reservedeelsite
Brugsanvisning, vedligeholdelse og reservedeelsite

Parte 2
Deel 2
Del 2



M2.38 NO-SAG

cod. 1728240

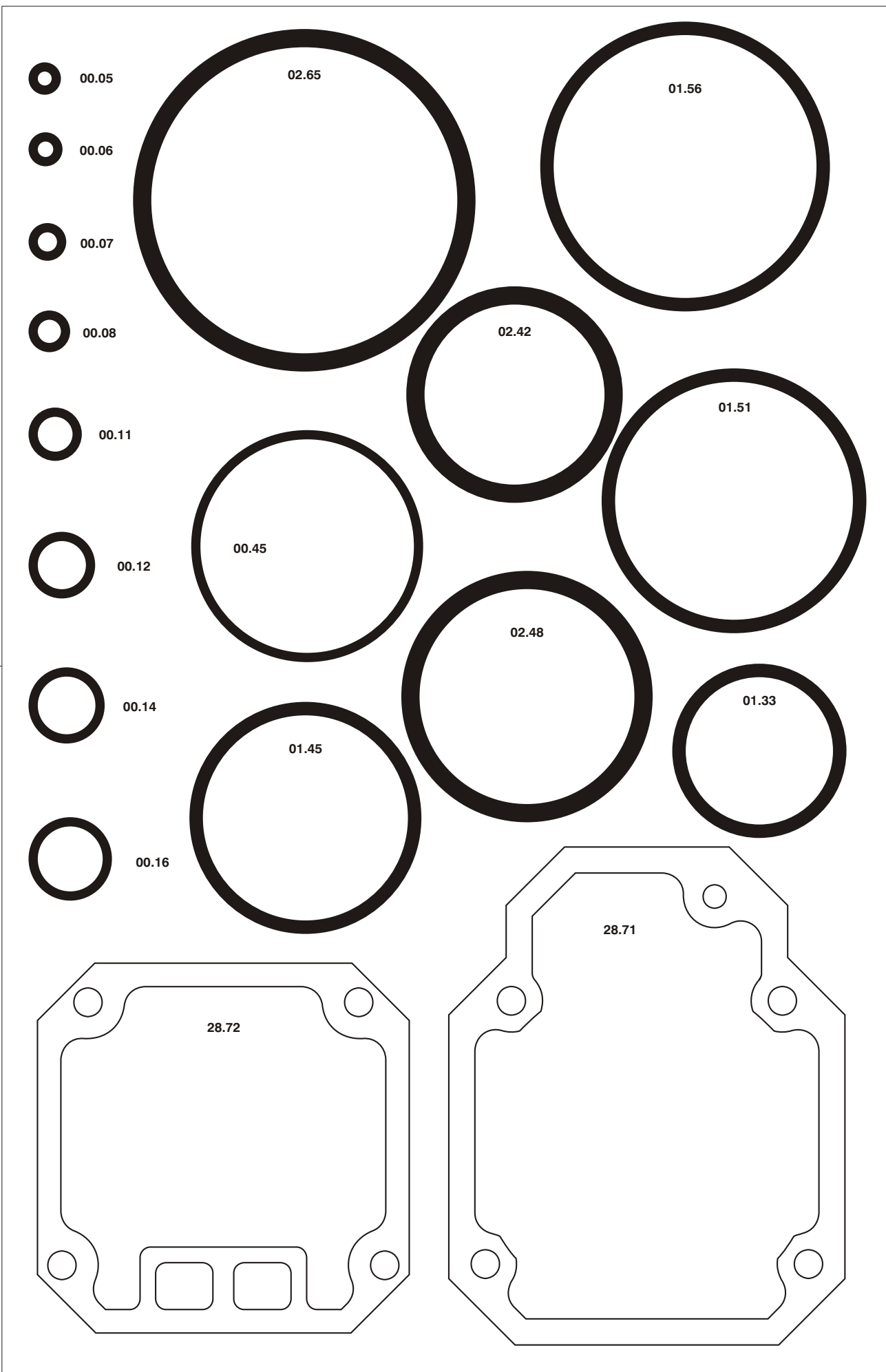

00.77.1

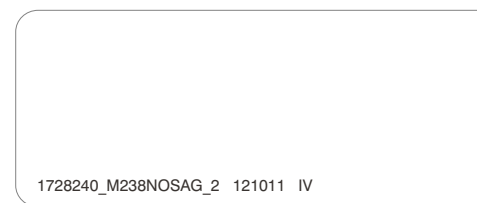

1728240_M238NOSAG_2 121011 IV

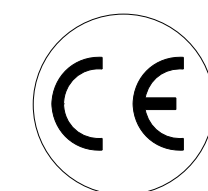

Dati tecnici Technical data Technische daten	Données techniques Datos tècnicos	Dados tècnicos Technischegegevens Tecniske data
--	--------------------------------------	---

Misure impiegabili mm Usable lengths mm Gebrauchliche Längen mm	Mesures utilisable mm Medidas que se pueden emplear mm	Medidas que se podem utilizar mm Te gebruiken engtes in mm Brugbare laengder i mm	20 ÷ 40
Capacità caricatore n° punti Magazine capacity No. of fasteners Magazinkapazität Nägel	Capacité chargeur n° de points Capacidad cargador n° puntos	Capacitade carregador n° pontos Capaciteit magazijn in aantal spijkers Kapacitet af magasin antal klemme	145
Pressione d'esercizio Working pressure Betriebsdruck	Pression de fonctionnement Presión de trabajo	Pressao de trabalho Werkdruk Arbejds tryk bar	5 ÷ 7,5 bar 70 ÷ 105 psi
Consumo aria litri/colpo Air consumption litres/shot Luftverbrauch Liter/Schlag	Consommation air litre/coup Consumo aire-litros/golpe	Consumo ar litro/golpe Luchtverbruik liter/schot Luftforbrug liter/skud	1,00
Peso kg Weight kg Gewicht kg	Poids kg Peso kg	Peso kg Gewicht in kg Vaegt kg	1,80
Dimensioni (AxBxH) mm Dimensions mm Größe mm	Dimension mm Dimensiones mm	Dimencoes mm Afmetingen in mm Dimensioner mm	345x77x245
EN 12549 :1999 ISO 11201 :1995			
Pressione sonora in pos. operatore Sound pressure at the workstation Lärmintensität am Arbeitsplatz	Pression acoustique près de l'opérateur Presión sonora en posición encargado	Intensidade sonora perto do operador Geluidssterkte op de werkplek Lydstyrke på operatorposten	86,1 dB(A)
EN 12549 :1999 ISO 3744 :1994			
Potenza sonora emessa Emitted sound power Ausgestrahlte Lärmintensität	Puissance acoustique émise Potencia sonora emitida	Potência sonora emitida Uitgestraalde geluidssterkte Udsendt lydstryrke	94,9 dB(A)
EN 28662 :1992 ISO 5349 :1986 ISO 8662 -11			
Valore medio ponderato di vibrazione sull'impugnatura Weighted mean value of vibration on the grip Mittlerer Vibrationswert, am Griff Gemessen	Valeur moyenne pondérée de vibration mesurée sur la poignée Valor medio ponderado de vibracion medida en la empunadura	Valor medio ponderado de vibracao medida no punho Gewogen gemiddelde vibratiewaarde Middelvaardi af vibrationer pa handtaget	2,6 m/s²

Tipo di punto
Type of fastener
Befestigungselement
Type d'agrafe
Tipo de punto
Tipo de ponto
Type nietjes
Tilspændingstype

M2

1,40x1,60

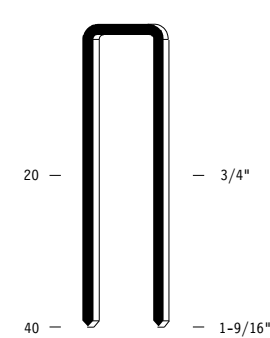

7,9

Gauge: 16
Crown: .421" (7/16")

Parti di ricambio - Spare parts - Ersatzteile - Pièces de rechange - Piezas de repuesto
- Partes sobresselentes - Tabel te raadplegen - Reservedele

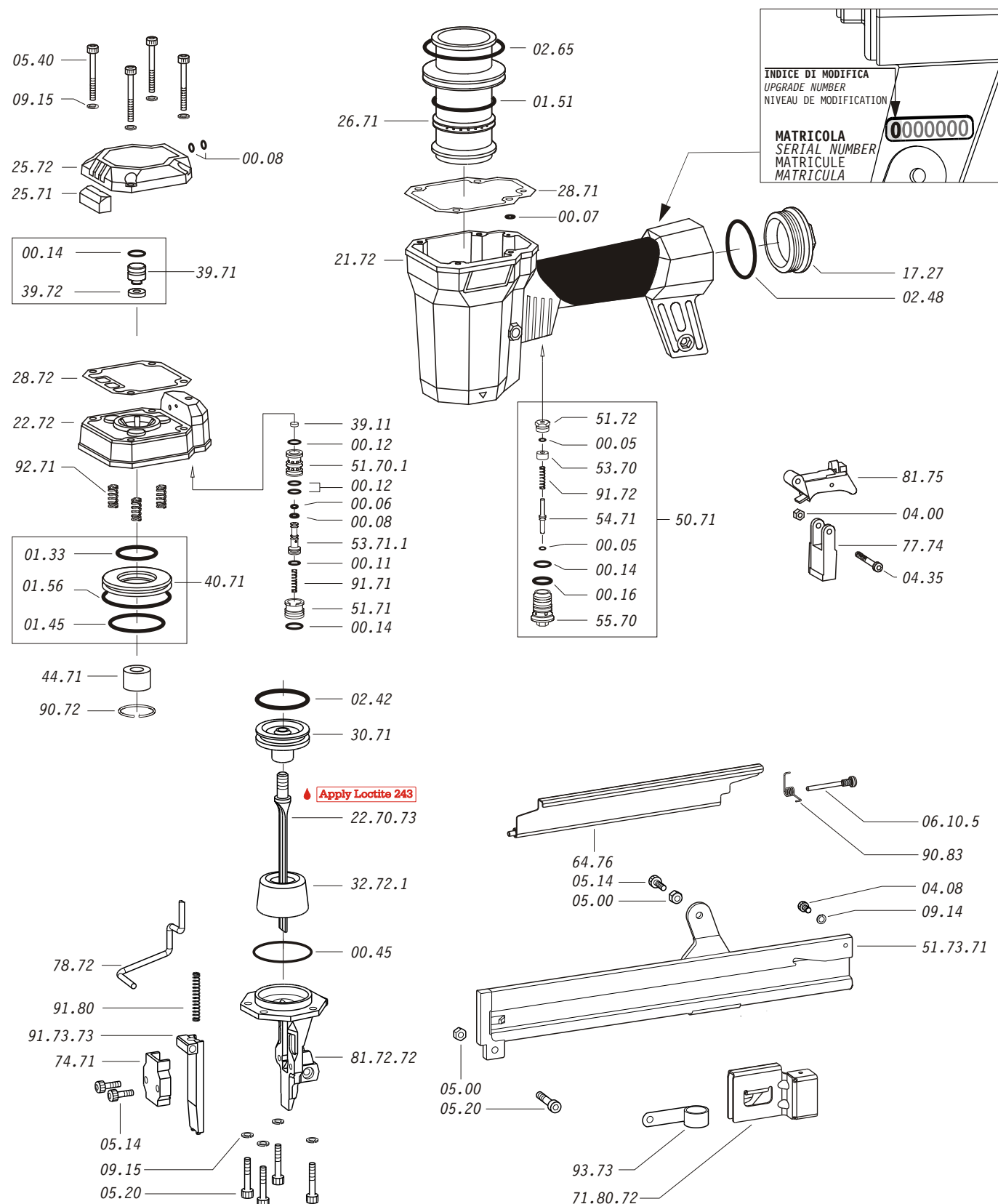

Dotazioni - Equipment - Ausrüstung - Équipements - Equipamiento - Equipamento - Uitrusting - Udstyr

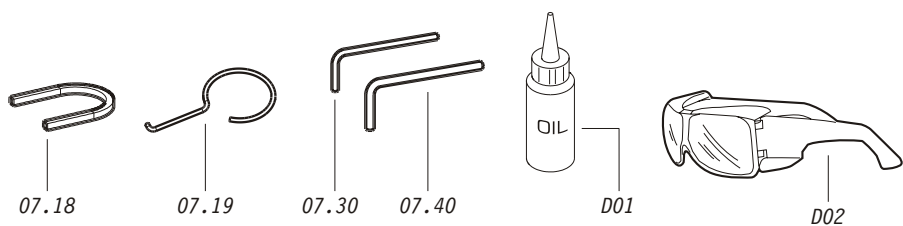

M2.38 NO-SAG

cod. 1728240

Parti di ricambio - Spare parts - Ersatzteile - Pièces de rechange - Piezas de repuesto
- Partes sobresselentes - Tabel te raadplegen - Reservedele

Cod.	Descrizione	Description
00.05	O-Ring	O-Ring
00.06	O-Ring	O-Ring
00.07	O-Ring	O-Ring
00.08	O-Ring	O-Ring
00.11	O-Ring	O-Ring
00.12	O-Ring	O-Ring
00.14	O-Ring	O-Ring
00.16	O-Ring	O-Ring
00.45	O-Ring	O-Ring
01.33	O-Ring	O-Ring
01.45	O-Ring	O-Ring
01.51	O-Ring	O-Ring
01.56	O-Ring	O-Ring
02.42	O-Ring	O-Ring
02.48	O-Ring	O-Ring
02.65	O-Ring	O-Ring
04.00	Dado	Nut
04.08	Vite	Screw
04.35	Vite	Screw
05.00	Dado	Nut
05.14	Vite	Screw
05.20	Vite	Screw
05.40	Vite	Screw
06.10.5	Vite	Screw
07.18	Chiave pistone	Piston wrench
07.19	Estrattore	Extractor
07.30	Chiave esagonale	Hex. bar wrench
07.40	Chiave esagonale	Hex. bar wrench
09.14	Rondella	Washer
09.15	Rondella	Washer
17.27	Tappo	Inlet cap
21.72	Corpo	Body
22.72	Testa	Head
25.71	Silenziatore	Silencer
25.72	Deflettore scarico	Exhaust deflector
26.71	Cilindro	Cylinder
28.71	Guarnizione testa	Head gasket
28.72	Guarnizione testa	Head gasket
30.71	Pistone	Piston
32.72.1	Ammortizzatore	Bumper
39.11	Guarnizione servovalvola	Servo valve gasket
39.71	Valvola scarico completa	Exhaust valve assembled
39.72	Guarnizione valvola scarico	Exhaust valve gasket
40.71	Valvola completa	Valve assembled
44.71	Ammortizzatore sup.	Upper bumper
50.71	Pulsante completo	Trigger valve assembled
51.70.1	Cilindro servovalvola	Servo valve cylinder
51.71	Boccola servovalvola	Servo valve bushing
51.72	Premistoppa	Stuffing box
53.70	Distanziale	Spacer
53.71.1	Pistone servovalvola	Servo valve piston
54.71	Pulsante	Trigger valve
55.70	Raccordo	Trigger valve bush
64.76	Carter	Hold down
74.71	Guida testina	Nose plate guide
77.74	Guida sicura	Safety guide
78.72	Sicura	Safety
81.75	Grilletto comando completo	Trigger assembled
90.72	Molla	Spring
90.83	Molla	Spring
91.71	Molla	Spring
91.72	Molla	Spring
91.80	Molla	Spring
92.71	Molla	Spring
93.73	Molla	Spring
22.70.73	Battente	Driver
51.73.71	Caricatore	Magazine
71.80.72	Spingipunto	Pusher
81.72.72	Controtestina	Nose
91.73.73	Testina	Nose plate
D01	Bocchetta olio	Oiler
D02	Occhiali protettivi	Protective goggles

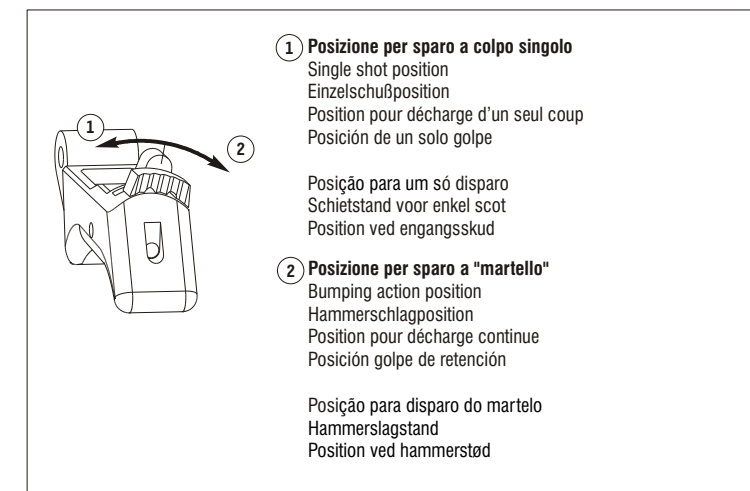
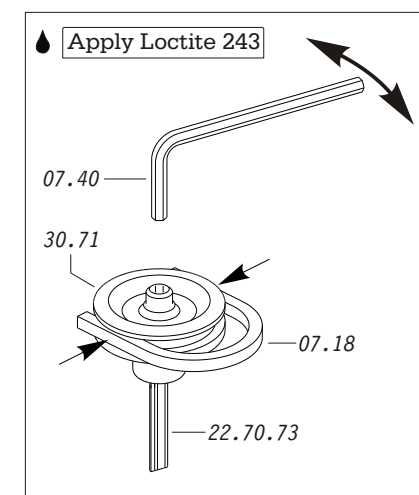
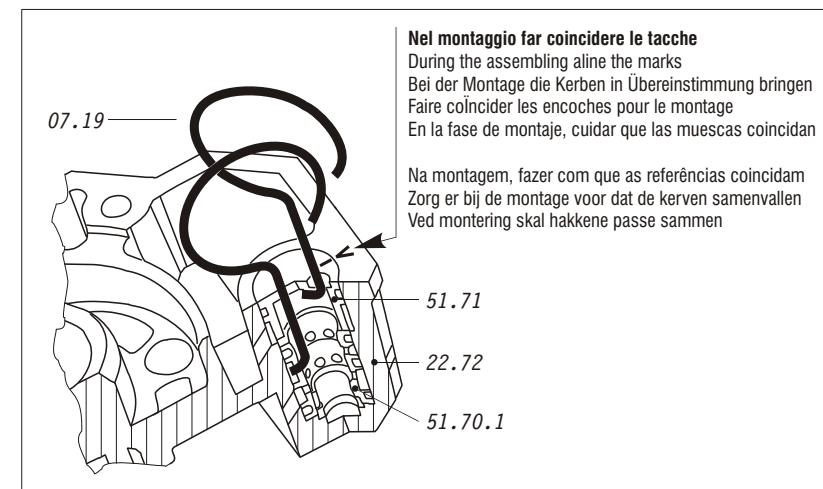

1728240_M238NOSAG_2_121011_IV

M2.38 NO-SAG cod. 1728240

Indice di modifica Upgrade number

2

.....