

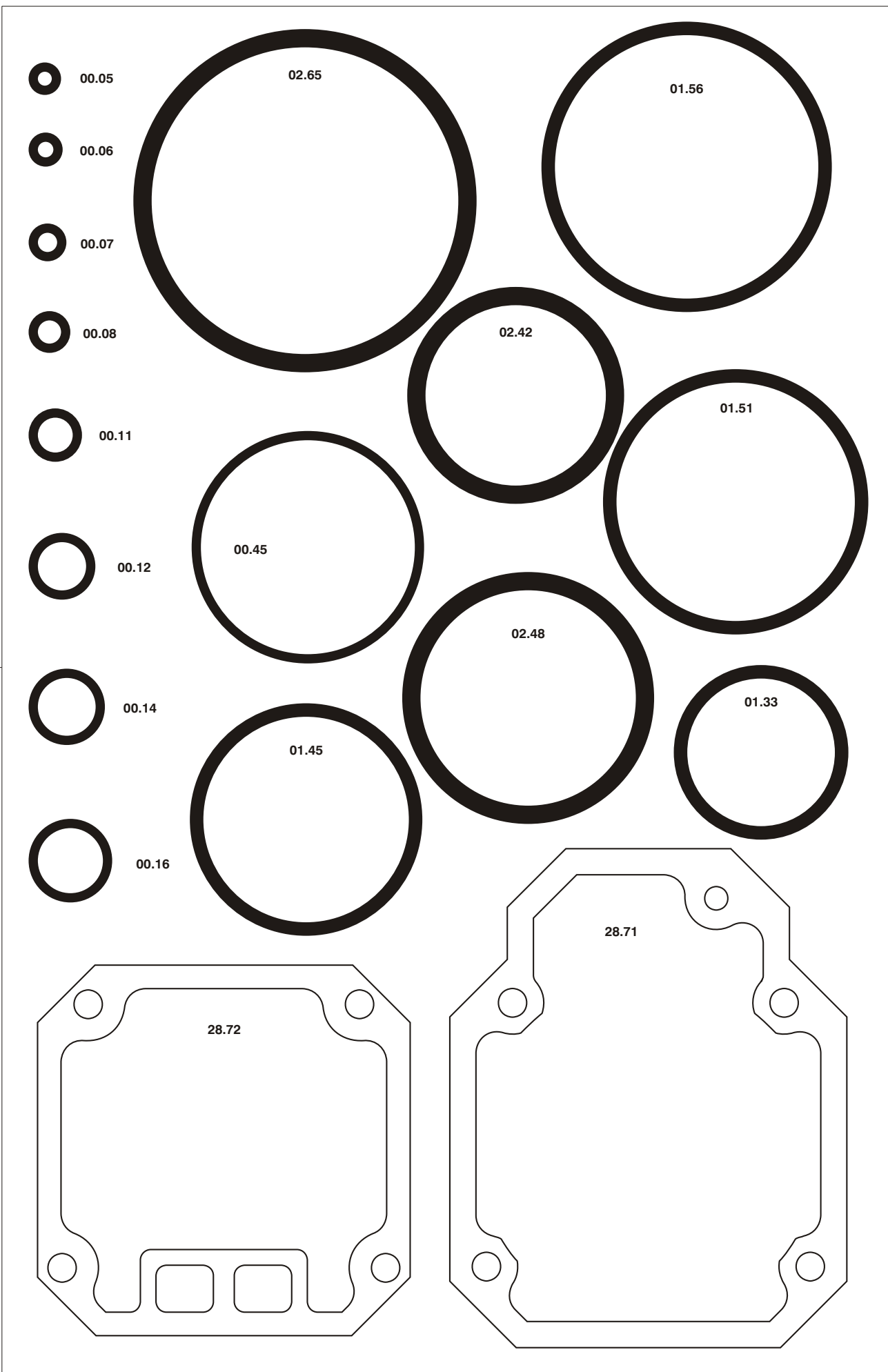

**Manuale d'uso, manutenzione e parti di ricambio** **Parte 2**  
**Use, maintenance and spare parts manual** **Part 2**  
**Gebrauchsanweisung, Instandhaltungsrichtlinien und Ersatzteile** **Teil 2**  
**Manuel d'utilisation, entretien et pièces de rechange** **Partie 2**  
**Manual de uso, mantenimiento y repuestos** **Part 2**

**Manual de utilização, manutenção e partes sobresselentes** **Parte 2**  
**Handleiding voor gebruik, onderhoud en reservedelslste** **Deel 2**  
**Brugsanvisning, vedligeholdelse og reservedelslste** **Del 2**



1729500CP\_WS38CP\_2 220910 IV

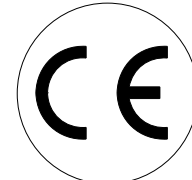

# WS.38 CP

cod. 1729500CP

Dati tecnici Technical data Technische daten	Données techniques Datos tècnicos	Dados tècnicos Technischegegevens Tecniske data
<b>Misure impiegabili mm</b> Usable lengths mm Gebrauchliche Längen mm	Mesures utilisable mm Medidas que se pueden emplear mm	Medidas que se podem utilizar mm Te gebruiken engtes in mm Brugbare laengder i mm
<b>Capacità caricatore n° punti</b> Magazine capacity No. of fasteners Magazinkapazität Nägel	Capacité chargeur n° de points Capacidad cargador n° puntos	Capacidade carregador n° pontos Capaciteit magazijn in aantal spijkers Kapacitet af magasin antal klemme
<b>Pressione d'esercizio</b> Working pressure Betriebsdruck	Pression de fonctionnement Presión de trabajo	Pressao de trabalho Werkdruk Arbejds tryk bar
<b>Consumo aria litri/colpo</b> Air consumption litres/shot Luftverbrauch Liter/Schlag	Consommation air litre/coup Consumo aire-litros/golpe	Consumo ar litro/golpe Luchtverbruik liter/schot Luftforbrug liter/skud
<b>Peso kg</b> Weight kg Gewicht kg	Poids kg Peso kg	Peso kg Gewicht in kg Vaegt kg
<b>Dimensioni (AxBxH) mm</b> Dimensions mm Größe mm	Dimension mm Dimensiones mm	Dimencoes mm Afmetingen in mm Dimensioner mm
<b>EN 12549 :1999 ISO 11201 :1995</b>		
<b>Pressione sonora in pos. operatore</b> Sound pressure at the workstation Lärmintensität am Arbeitsplatz	Pression acoustique près de l'opérateur Presión sonora en posición encargado	Intensidade sonora perto do operador Geluidssterkte op de werkplek Lydstyrke på operatorposten
<b>EN 12549 :1999 ISO 3744 :1994</b>		
<b>Potenza sonora emessa</b> Emitted sound power Ausgestrahlte Lärmintensität	Puissance acoustique émise Potencia sonora emitida	Potência sonora emitida Uitgestraalde geluidssterkte Udsendt lydstryrke
<b>EN 28662 :1992 ISO 5349 :1986 ISO 8662 -11</b>		
<b>Valore medio ponderato di vibrazione sull'impugnatura</b> Weighted mean value of vibration on the grip Mittlerer Vibrationswert, am Griff Gemessen	Valeur moyenne pondérée de vibration mesurée sur la poignée Valor medio ponderado de vibracion medida en la empuñadura	Valor medio ponderado de vibracao medida no punho Gewogen gemiddelde vibratiewaarde Middelvaardi af vibrationer pa handtaget

**Tipo di punto**  
Type of fastener  
Befestigungselement  
Type d'agrafe  
Tipo de punto

Tipo de ponto  
Type nietjes  
Tilspændingstype

**WS**

1,40x1,60

Crown: .982" (1")  
Gauge: 16

Parti di ricambio - Spare parts - Ersatzteile - Pièces de rechange - Piezas de repuesto  
- Partes sobresselentes - Tabel te raadplegen - Reservedele

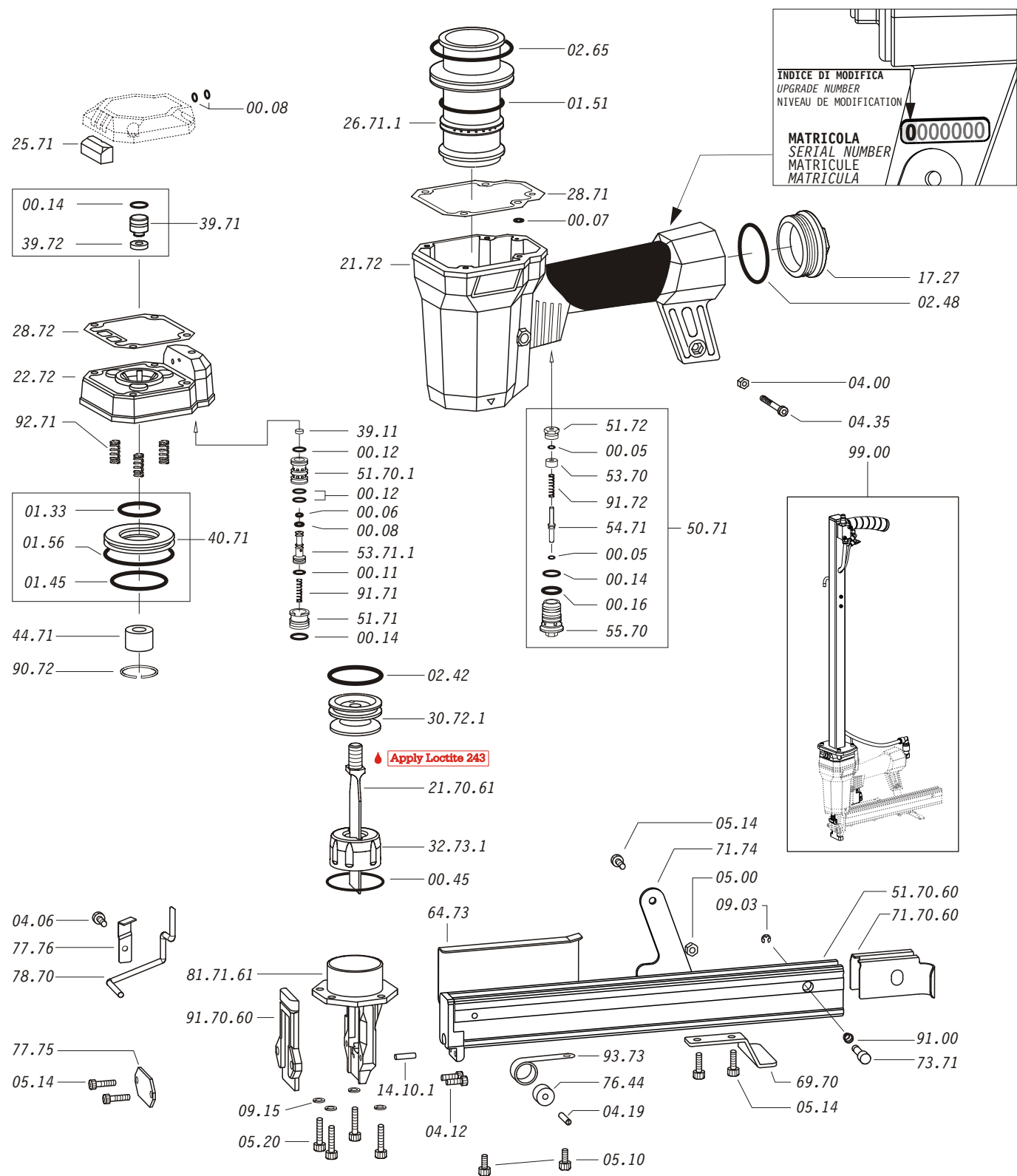

Dotazioni - Equipment - Ausrüstung - Équipements - Equipamiento - Equipamento - Uitrusting - Udstyr

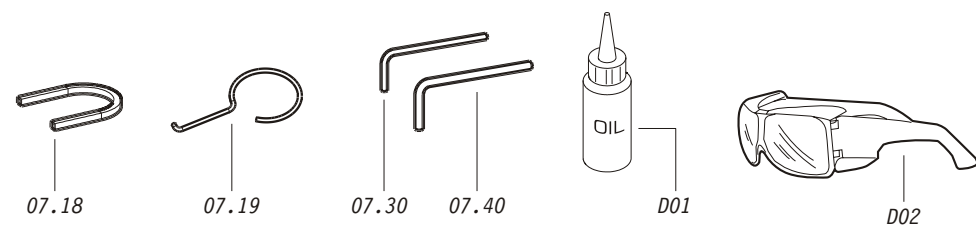

**WS.38 CP**

cod. 172950CP

Parti di ricambio - Spare parts - Ersatzteile - Pièces de rechange - Piezas de repuesto  
- Partes sobresselentes - Tabel te raadplegen - Reservedele

Cod.	Descrizione	Description
00.05	O-Ring	O-Ring
00.06	O-Ring	O-Ring
00.07	O-Ring	O-Ring
00.08	O-Ring	O-Ring
00.11	O-Ring	O-Ring
00.12	O-Ring	O-Ring
00.14	O-Ring	O-Ring
00.16	O-Ring	O-Ring
00.45	O-Ring	O-Ring
01.33	O-Ring	O-Ring
01.45	O-Ring	O-Ring
01.51	O-Ring	O-Ring
01.56	O-Ring	O-Ring
02.42	O-Ring	O-Ring
02.48	O-Ring	O-Ring
02.65	O-Ring	O-Ring
04.00	Dado	Nut
04.06	Vite	Screw
04.12	Vite	Screw
04.19	Vite	Screw
04.35	Vite	Screw
05.00	Dado	Nut
05.10	Vite	Screw
05.14	Vite	Screw
05.20	Vite	Screw
07.18	Chiave pistone	Piston wrench
07.19	Estrattore	Extractor
07.30	Chiave esagonale	Hex. bar wrench
07.40	Chiave esagonale	Hex. bar wrench
09.03	Anello elastico	Elastic ring
14.10.1	Spina	Pin
17.27	Tappo	Inlet cap
21.72	Corpo	Body
22.72	Testa	Head
25.71	Silenziatore	Silencer
25.72	Deflettore scarico	Exhaust deflector
26.71.1	Cilindro	Cylinder
28.71	Guarnizione testa	Head gasket
28.72	Guarnizione testa	Head gasket
30.72.1	Pistone	Piston
32.73.1	Ammortizzatore	Bumper
39.11	Guarnizione servovalvola	Servo valve gasket
39.71	Valvola scarico completa	Exhaust valve assembled
39.72	Guarnizione valvola scarico	Exhaust valve gasket
40.71	Valvola completa	Valve assembled
44.71	Ammortizzatore sup.	Upper bumper
50.71	Pulsante completo	Trigger valve assembled
51.70.1	Cilindro servovalvola	Servo valve cylinder
51.71	Boccola servovalvola	Servo valve bushing
51.72	Premistoppa	Stuffing box
53.70	Distanziale	Spacer
53.71.1	Pistone servovalvola	Servo valve piston
54.71	Pulsante	Trigger valve
55.70	Raccordo	Trigger valve bush
64.73	Carter	Hold down
69.70	Supporto	Support
71.74	Reggicaricatore	Support
73.71	Perno	Pin
76.44	Rullo molla	Roller
77.75	Staffa sicura	Safety plate
77.76	Staffa rinvio sicura	Safety protection plate
78.70	Rinvio sicura	Safety rod
90.72	Molla	Spring
91.00	Molla	Spring
91.71	Molla	Spring
91.72	Molla	Spring
92.71	Molla	Spring
93.73	Molla	Spring
99.00	Assieme dispositivo prolunga	Extension device assy
21.70.61	Battente	Driver
51.70.60	Caricatore	Magazine
71.70.60	Spingipunto	Pusher
81.71.61	Controtestina	Nose
91.70.60	Testina	Nose plate
D01	Bocchetta olio	Oiler
D02	Occhiali protettivi	Protective goggles

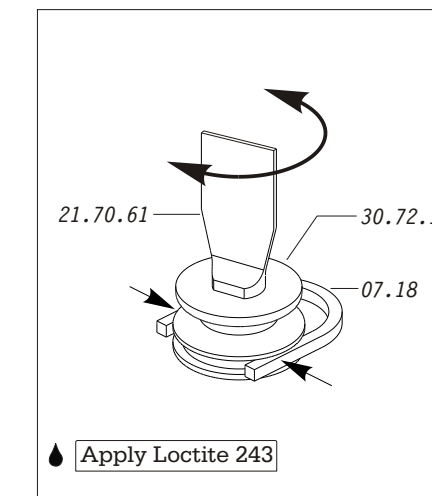
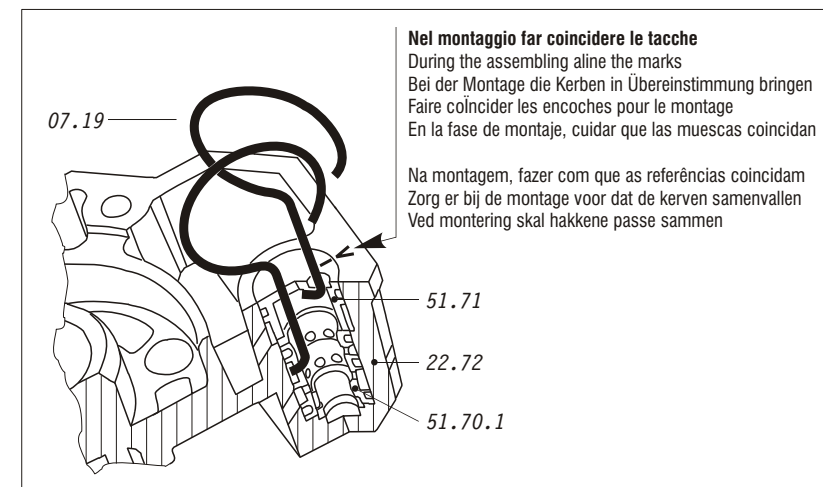

172950CP\_WS38CP\_2\_220910\_IV

**WS.38 CP**

cod. 172950CP

Indice di modifica  
Upgrade number

**2**

**2246614**

Parti di ricambio - Spare parts - Ersatzteile - Pièces de rechange - Piezas de repuesto  
 - Partes sobresselentes - Tabel te raadplegen - Reservedele

Tubi di connessione - Connection Tube

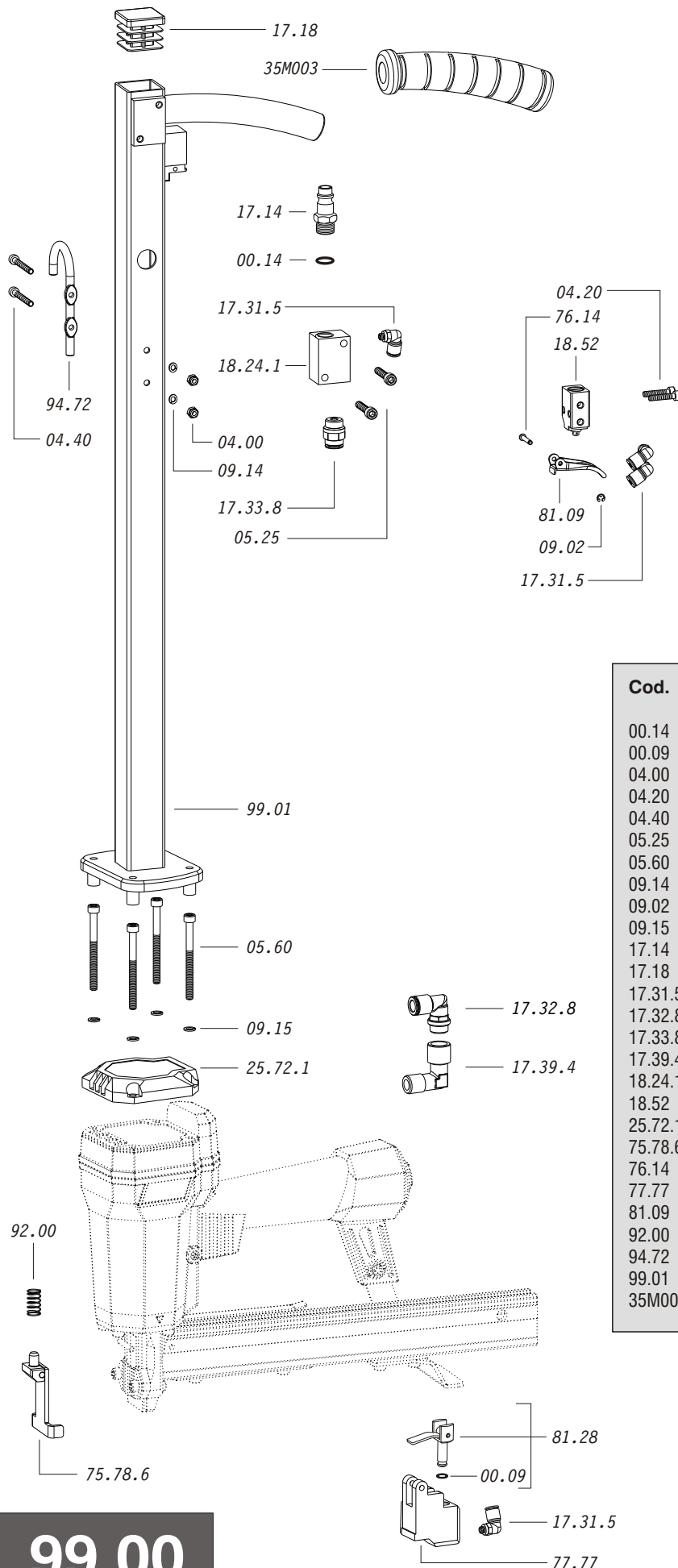
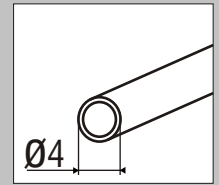
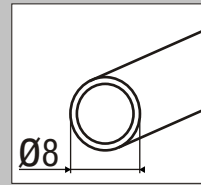

Cod.	Descrizione	Description
00.14	O-Ring	O-Ring
00.09	O-Ring	O-Ring
04.00	Dado	Nut
04.20	Vite	Screw
04.40	Vite	Screw
05.25	Vite	Screw
05.60	Vite	Screw
09.14	Rondella	Washer
09.02	Anello elastico	Elastic ring
09.15	Rondella	Washer
17.14	Attacco Rapido	Air Plug
17.18	Tappo	Cap
17.31.5	Raccordo "L" ø4	Connector "Elbow" ø4
17.32.8	Raccordo "L" ø8	Connector "Elbow" ø8
17.33.8	Raccordo "Dritto" ø8	Connector "Straight" ø8
17.39.4	Congiunzione "L"	Union "elbow"
18.24.1	Distributore	Distributor
18.52	Valvola comando	Command Valve
25.72.1	Deflettore	Deflector
75.78.6	Sicura	Safety
76.14	Perno	Pin
77.77	Guida sicura	Safety guide
81.09	Grilletto comando	Trigger
92.00	Molla	Spring
94.72	Gancio	Hook
99.01	Prolunga	Extension
35M003	Copri Manico	Rubber handle

99.00