

Azionamento sequenziale singolo
 Single sequential actuation

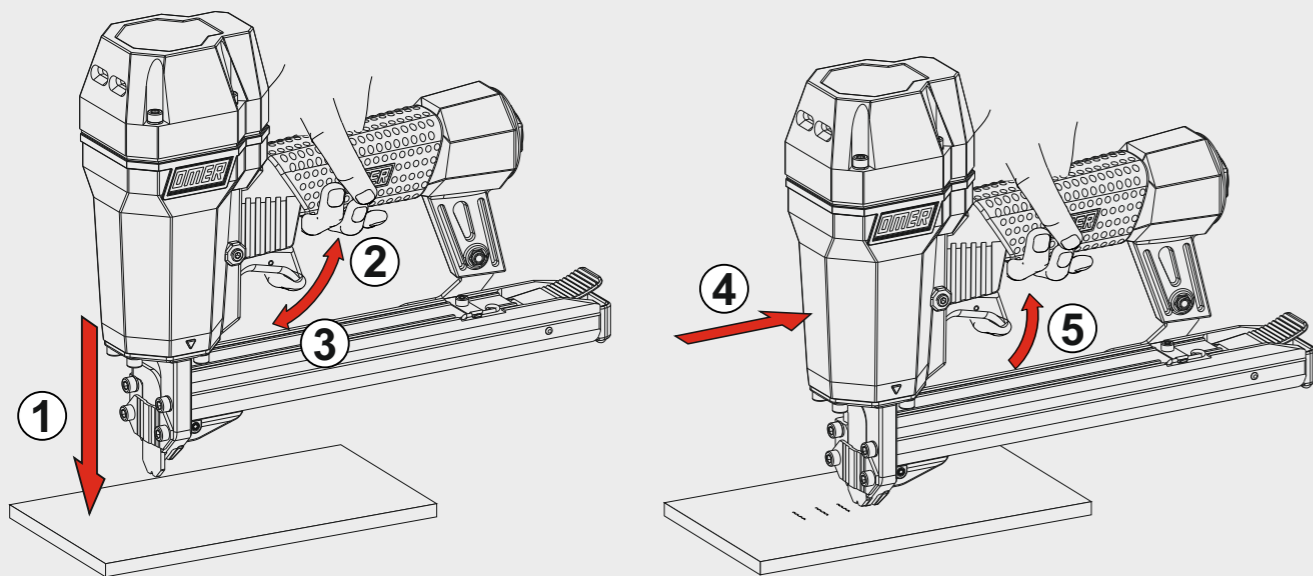

Manutenzione - Maintenance

Sostituzione battente
 Driver replacing

Apply Loctite 243

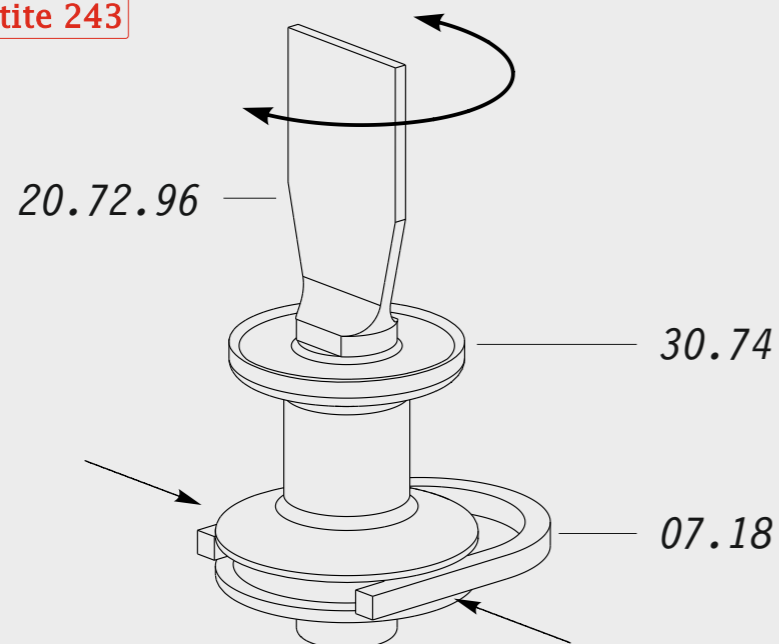

Manuale d'uso, manutenzione e parti di ricambio	Parte 2
Manual for use, maintenance and spare parts	Part 2
Bedienungs- und Wartungshandbuch sowie Ersatzteilleiste	Teil 2
Mode d'emploi, de maintenance et pièces de rechange	Partie 2
Manual de uso, mantenimiento y recambios	Part 2
Εγχειρίδιο χρήσης, συντήρησης και ανταλλακτικών	Μέρος 2
Manual de uso, manutenção e peças sobresselentes	Parte 2
Handleiding voor gebruik, onderhoud en wisselstukken	Deel 2
Kullanım, bakım ve yedek parça kılavuzu	Kısım 2
Användar-, underhålls- och reservdelshandbok	Del 2



CFP.15

cod. 17296610



Dati tecnici Technical data Technische Daten Tekniska data	Caractéristiques techniques Datos técnicos Τεχνικά χαρακτηριστικά	Dados técnicos Technische gegevens Teknik veriler
--	--	--

Misure impiegabili Lengths Verwendbare Nagellänge Dimensioner som kan användas	Dimensions utiles Medidas de longitud Μήκος Αναλωσίμου	Medidas utilizáveis Toepasbare afmetingen Boy	10 ÷ 15
Capacità caricatore n° punti Magazine capacity Magazinkapazität Nägel Magasinkapacitet Antal punkter	Capacité chargeur n° de points Capacidad cargador n° puntos Δυνατότητα γεμιστέρα	Capacidade carregador n° pontos Capaciteit magazijn in aantal spijkers Dergi kapasitesi	225
Pressione d'esercizio Operating pressure Betriebsdruck Drifttryck	Pression d'exercice Presión de servicio Πίεση λειτουργίας	Pressão de serviço Werkdruk Çalışma basıncı	5 ÷ 8,3 bar 70 ÷ 120 psi
Consumo aria Air consumption Luftverbrauch Luftförbrukning	Consommation d'air Consumo aire Κατανάλωση αέρα	Consumo ar Luchtverbruik Hava tüketimi	1,10
Peso Weight Gewicht Vikt	Poids Peso Βάρος	Peso Gewicht Ağırlık	2,95
Dimensioni Dimensions Abmessungen Dimensioner (AxBxH)	Dimensions Διαστάσεις	Dimensões Afmetingen Boyutlar	429x77x251 (LxWxH)

EN 12549 :2009 EN ISO 4871 :2009	Pressione sonora in pos. operatore Sound pressure in operator's position Schalldruck am Arbeitsplatz Ljudtryck på operatörsplatsen	Pression sonore poste Opérateur Presión sonora en la pos. del operador Ηχητική πίεση στη θέση του χειριστή Operatör pozisyonunda ses basıncı	92 dB(A) (K= 4 dB)
---	--	--	------------------------------

EN 12549 :2009 EN ISO 3746 :2011 EN ISO 4871 :2009	Potenza sonora emessa Sound power emitted Emitierte Schalleistung Avgiven ljudeffekt	Puissance sonore émise Potencia sonora emitida Εκπεμπόμενη ηχητική ισχύς	Potência sonora emitida Geëmitteerd geluidsvermogen Çıkan ses gücü (ses desibeli)	93 dB(A) (K= 4 dB)
---	--	---	--	------------------------------

CEN ISO/TS 8662-11 :2006 EN ISO 5349-2 :2004 EN 12096 :1999	Emissione vibratoria sull'impugnatura Vibratory emissions on handle Vibrationsemission am Griff Vibrationsemission på handtaget	Émission vibratoire sur la prise en main Emisión de vibraciones en la empuñadura Εκπεμπόμενες δονήσεις στη λαβή	Emissão vibratória na empunhadura Trillingsemissie op de handgreep Tutamak üzerinde vibrasyon emisyonları	< 2,5 m/s² (K= 2 m/s²)
--	---	--	--	-------------------------------------

Tipo di punto
Type of fastener
Befestigungsmittel
Tipo de punto
Τύπος αναλωσίμου
Tipo de agrafó
Type nietjes
Zimba ve çivi tipleri
Typ av stygn

CF 1000

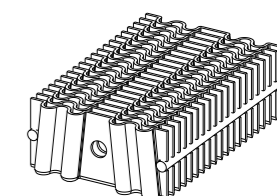
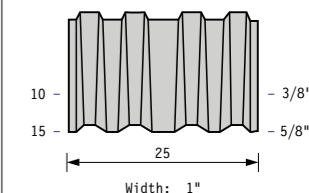

Parti di ricambio - Spare parts - Ersatzteile - Pièces de rechange - Recambios
Ανταλλακτικά - Partes sobresselentes - Wisselstukken - Yedek parçalar - Reservdelar

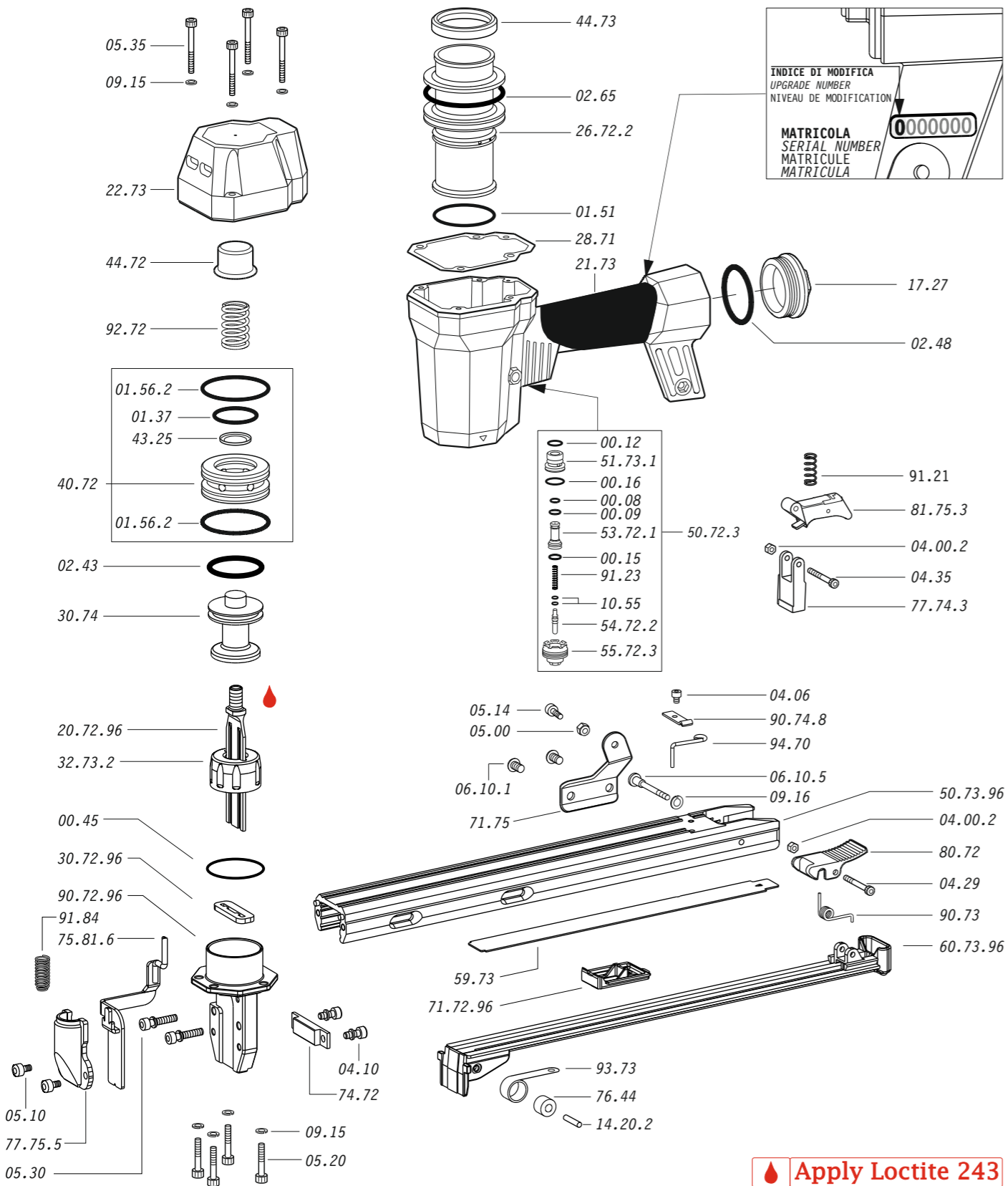

Apply Loctite 243

Dotazioni - Equipment - Ausstattung - Outillage - Dotaciones - Εξοπλισμός
Dotações - Uitrusting - Donanımlar - Utrustning

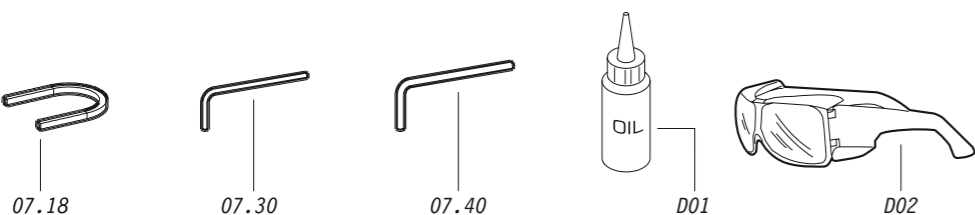

CFP.15

cod. 17296610

Parti di ricambio - Spare parts - Ersatzteile - Pièces de rechange - Recambios
Ανταλλακτικά - Partes sobresselentes - Wisselstukken - Yedek parçalar - Reservdelar

Cod.	Descrizione	Description
00.08	O-Ring	O-Ring
00.09	O-Ring	O-Ring
00.12	O-Ring	O-Ring
00.15	O-Ring	O-Ring
00.16	O-Ring	O-Ring
00.45	O-Ring	O-Ring
01.37	O-Ring	O-Ring
01.51	O-Ring	O-Ring
01.56.2	O-Ring	O-Ring
02.43	O-Ring	O-Ring
02.48	O-Ring	O-Ring
02.65	O-Ring	O-Ring
04.00.2	Dado	Nut
04.06	Vite	Screw
04.10	Vite	Screw
04.29	Vite	Screw
04.35	Vite	Screw
05.00	Dado	Nut
05.10	Vite	Screw
05.14	Vite	Screw
05.20	Vite	Screw
05.30	Vite	Screw
05.35	Vite	Screw
06.10.1	Vite	Screw
06.10.5	Vite	Screw
07.18	Chiave pistone	Piston wrench
07.30	Chiave esagonale	Hex. bar wrench
07.40	Chiave esagonale	Hex. bar wrench
09.15	Rondella	Washer
09.16	Rondella	Washer
10.55	O-Ring	O-Ring
14.20.2	Spina	Pin
17.27	Tappo	Inlet cap
21.73	Corpo	Body
22.73	Testa	Head
26.72.2	Cilindro	Cylinder
28.71	Guarnizione testa	Head gasket
30.74	Pistone	Piston
32.73.2	Ammortizzatore	Bumper
40.72	Valvola completa	Valve assembled
43.25	Rondella	Washer
44.72	Guarnizione	Gasket
44.73	Guarnizione cilindro	Cylinder gasket
50.72.3	Pulsante completo	Trigger valve ass'y
51.73.1	Cilindro servovalvola	Servo valve cylinder
53.72.1	Pistone servovalvola	Servo valve piston
54.72.2	Pulsante	Trigger valve
55.72.3	Raccordo	Trigger valve bush
59.73	Distanziale	Spacer
71.75	Reggicaricatore	Support
74.72	Piastra	Plate
75.81.6	Sicura	Safety
76.44	Rullo molla	Roller
77.74.3	Guida sicura	Safety guide
77.75.5	Staffa sicura	Safety plate
80.72	Grilletto chiusura	Trigger
81.75.3	Grilletto cmd comp.	Trigger ass'Y
90.73	Molla	Spring
90.74.8	Molla	Spring
91.21	Molla	Spring
91.23	Molla	Spring
91.84	Molla	Spring
92.72	Molla	Spring
93.73	Molla	Spring
94.70	Fermo distanziale	Spacer stop
20.72.96	Battente	Driver
30.72.96	Rondella	Washer
50.73.96	Caricatore	Magazine
60.73.96	Carrello	Slider
71.72.96	Spingipunto	Pusher
90.72.96	Testina	Nose plate
D01	Bocchetta olio	Oiler
D02	Occhiali protettivi	Protective goggles

Guarnizioni - O-Rings - Dichtungen - Juntas - Δακτύλιος στεγανοποίησης - Vedantes - O-ringen - Contalar - O-ringar

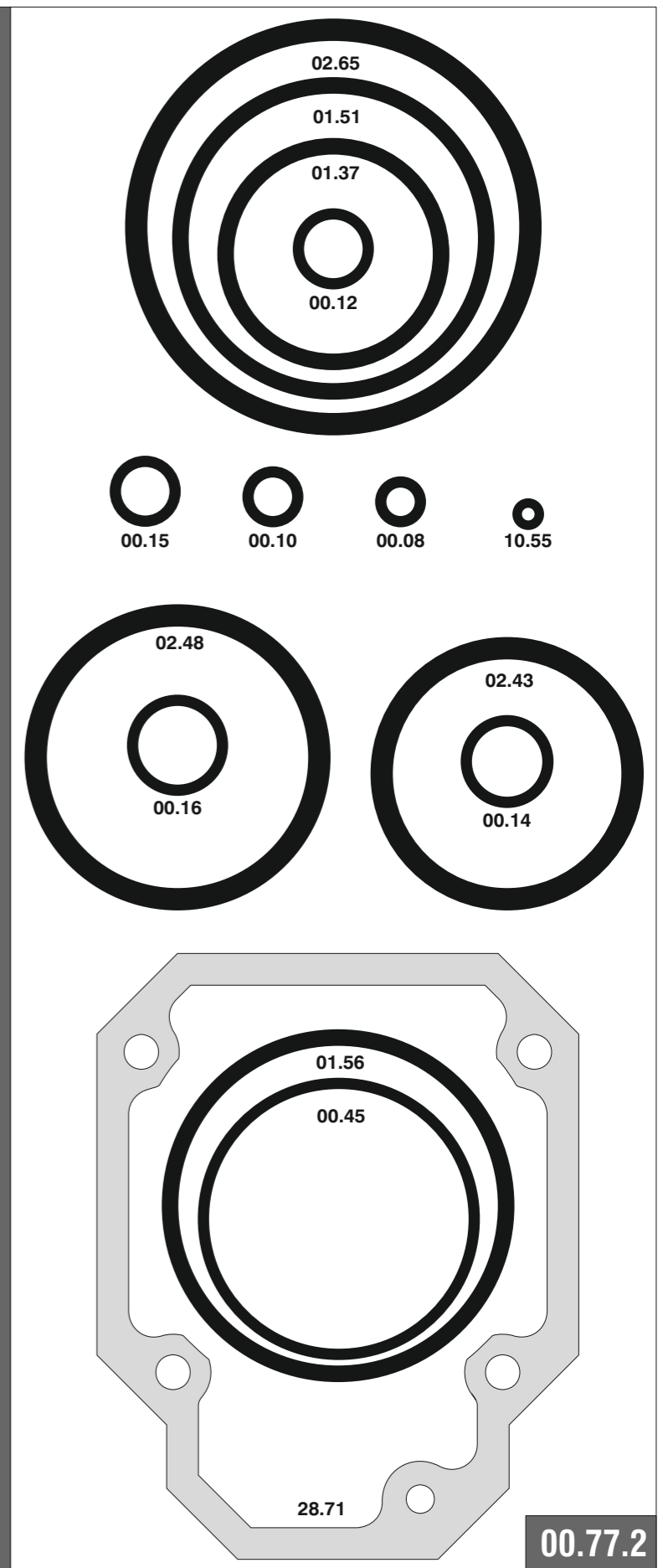

CFP.15

cod. 17296610

Indice di modifica
Upgrade number

2

Regolazione misura - Length adjustment - Längeneinstellung - Réglage des dimensions
Regulación de la medida - Ρύθμιση μήκους - Regulação medida - Lengte-afstelling - Boy ayarı - Justering av storleken

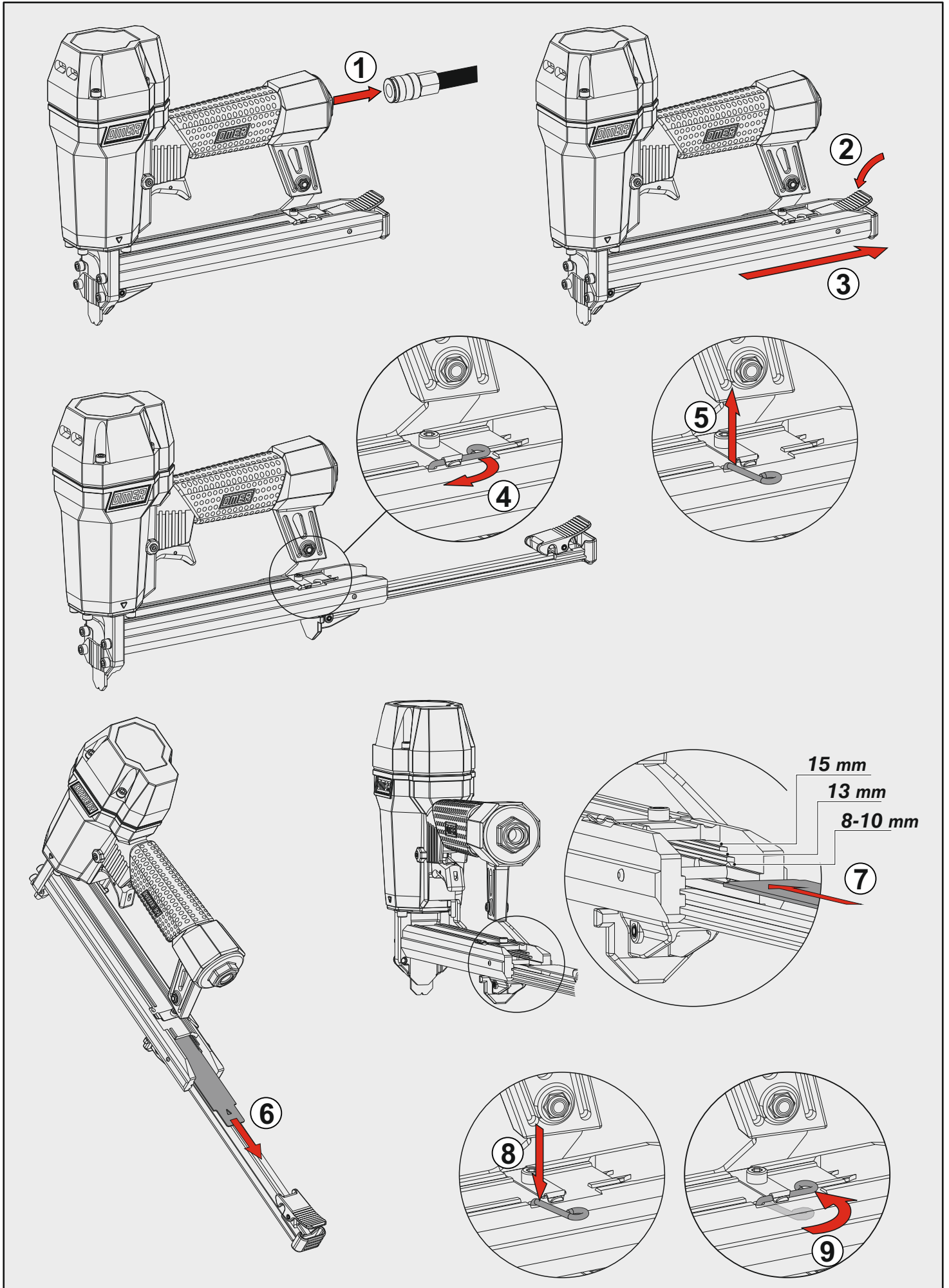

Disincemento - Jam clearing - Staubeseitigung - Décoincement - Desatascamiento - Απεμπλοκή
Desencravamento - Deblokkering bij vastlopen - Sikişma giderme - Rensning av igensättningar

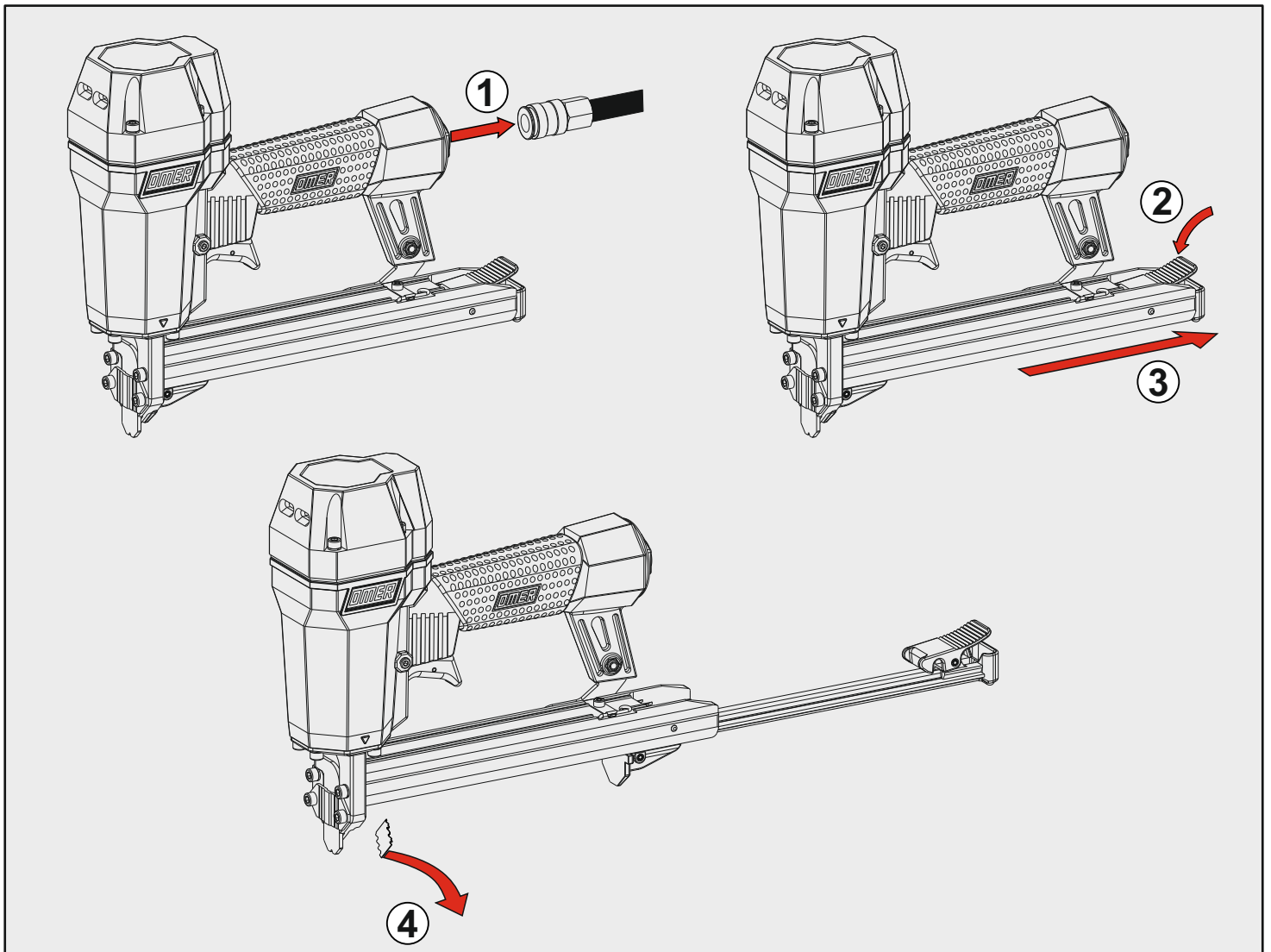

Caricamento - Loading - Laden - Chargement - Carga - Γέμισμα - Carregamento - Laden - Yükleme - Laddning

