

Caratteristiche - Features

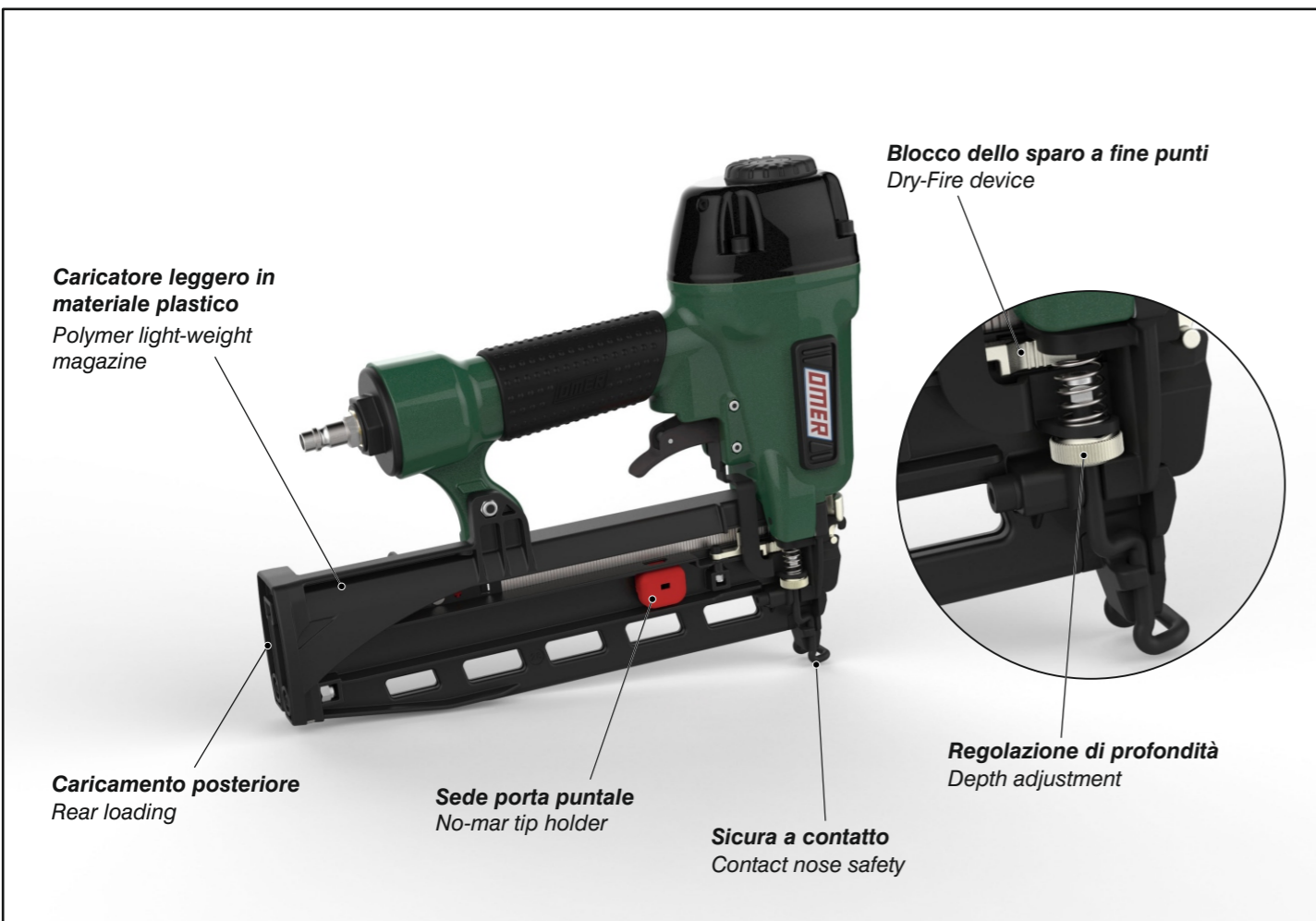
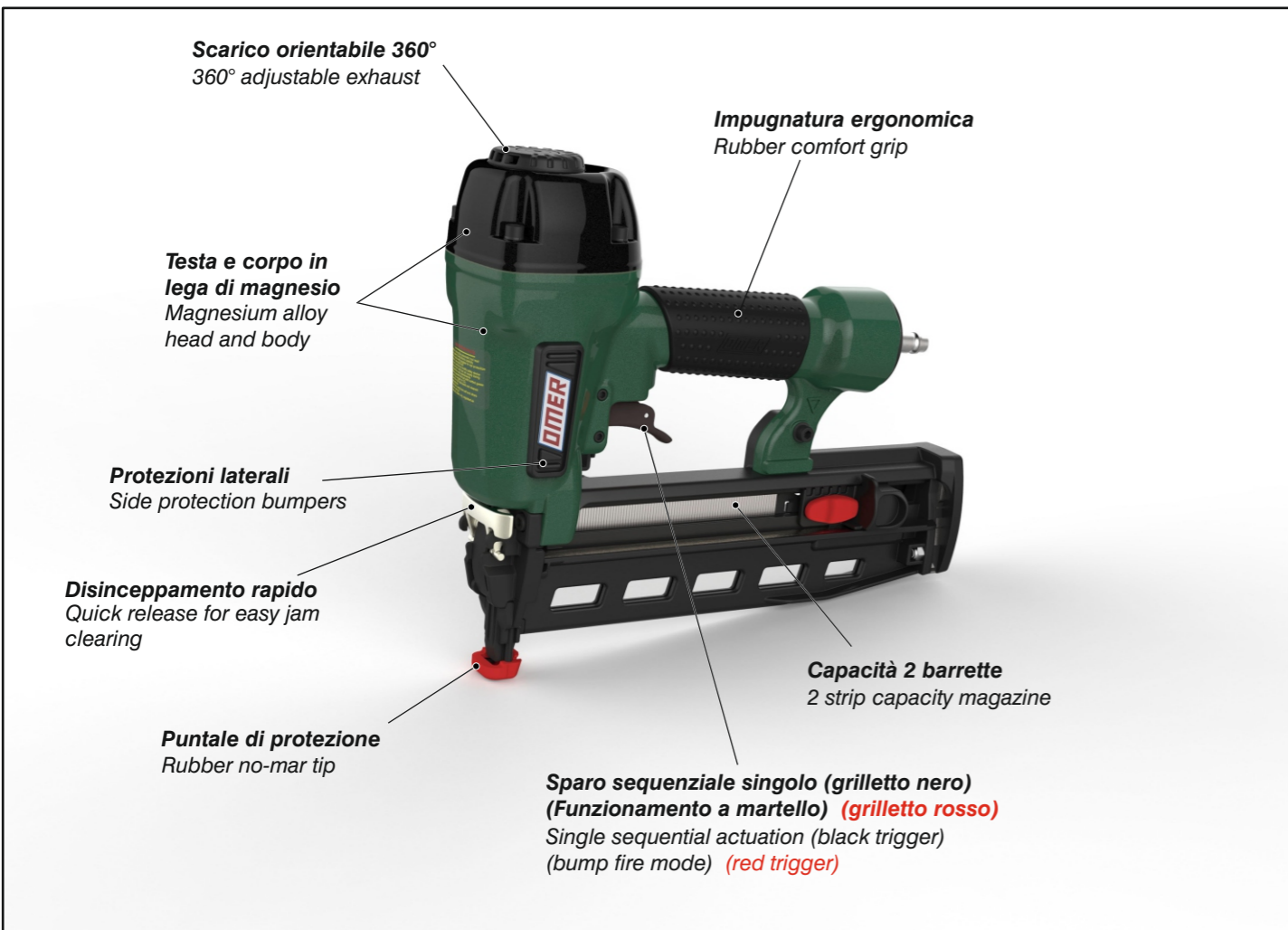

OMER

Manuale d'uso, manutenzione e parti di ricambio
Use, maintenance and spare parts manual
Gebrauchsanweisung, Instandhaltungsrichtlinien und Ersatzteile
Manuel d'utilisation, entretien et pièces de rechange
Manual de uso, mantenimiento y repuestos
Εγχειρίδιο χρήσης, συντήρησης και ανταλλακτικών
Manual de utilização, manutenção e partes sobresselentes
Handleiding voor gebruik, onderhoud en reservedelslste
Brugsanvisning, vedligeholdelse og reservedelslste

Parte 2
Part 2
Teil 2
Partie 2
Part 2
2° Μερὸς
Parte 2
Deel 2
Del 2



B17P.763

cod. 1741790

1741790_B17P763_4 270819 IV

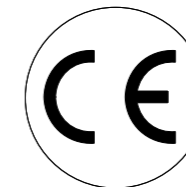

Dati tecnici Technical data Technische daten	Données techniques Datos tècnicos Τεχνικά χαρακτηριστικά	Dados tècnicos Technischegegevens Teknische data
--	--	--

Misure impieghiabili mm Usable lengths mm Gebrauchliche Längen mm	Mesures utilisables mm Medidas que se pueden emplear mm Διαστάσεις σε μμ	Medidas que se podem utilizar mm Te gebruiken engtes in mm Brugbare laengder i mm	12 ÷ 63
--	--	---	----------------

Capacità caricatore n° punti Magazine capacity No. of fasteners Magazinkapazität Nägel	Capacité chargeur n° de points Capacidad cargador n° puntos Δυνατότητα γεμιστέρα, σπινδύτερης	Capacidade carregador n° pontos Capaciteit magazijn in aantal spijkers Kapacitet af magasin antal klemme	85
---	---	--	-----------

Pressione d'esercizio Working pressure Betriebsdruck	Pression de fonctionnement Presión de trabajo Πίεση λειτουργίας ατμ.	Pressao de trabalho Werkdruk Arbejds tryk bar	5 ÷ 7,5 bar 70 ÷ 105 psi
---	--	---	---

Consumo aria litri/colpo Air consumption litres/shot Luftverbrauch Liter/Schlag	Consumption air litre/coup Consumo aire-litros/golpe Καταναλοση αερα λ/ξτρωπημα	Consumo ar litro/golpe Luchtverbruik liter/schot Luftforbrug liter/skud	0,75
--	---	---	-------------

Peso kg Weight kg Gewicht kg	Poids kg Peso kg Βαρος κγ	Peso kg Gewicht in kg Vaegt kg	1,70
---	---------------------------------	--------------------------------------	-------------

Dimensioni (AxBxH) mm Dimensions mm Größe mm	Dimension mm Dimensiones mm Δυνατότητα γεμιστέρα, σπινδύτερης	Dimencoes mm Afmetingen in mm Dimensioner mm	308x77x261
---	---	--	-------------------

EN 12549 :1999 ISO 11201 :1995 Pressione sonora in pos. operatore Sound pressure at the workstation Lärmintensität am Arbeitsplatz	Pression acoustique près de l'opérateur Presión sonora en posición encargado Ακουστική πίεση στη θέση χειριστού	Intensidade sonora perto do operador Geluidssterkte op de werkplek Lydstyrke på operatorposten	86,1 dB(A)
---	---	--	-------------------

EN 12549 :1999 ISO 3744 :1994 Potenza sonora emessa Emitted sound power Ausgestrahlte Lärmintensität	Puissance acoustique émise Potencia sonora emitida Ακουστική ισχυ	Potência sonora emitida Uitgestraalde geluidssterkte Udsendt lydstryke	94,9 dB(A)
---	---	--	-------------------

EN 28662 :1992 ISO 5349 :1986 ISO 8662 -11 Valore medio ponderato di vibrazione sull'impugnatura Weighted mean value of vibration on the grip Mittlerer Vibrationswert, am Griff Gemessen	Valeur moyenne pondérée de vibration mesurée sur la poignée Valor medio ponderado de vibracion medida en la empuñadura Μεσος ορος μετρησης κραδασμων στη χειρολαβη	Valor medio ponderado de vibracao medida no punho Gewogen gemiddelde vibratiewaarde Middelvaerdi af vibrationer pa handtaget	2,6 m/s²
--	--	--	-----------------

Tipo di punto
Type of fastener
Befestigungselement
Type d'agrafe
Tipo de punto
Τύπος κάρφιου
Tipo de ponto
Type nietjes
Tilspændingstype

Brads 17P

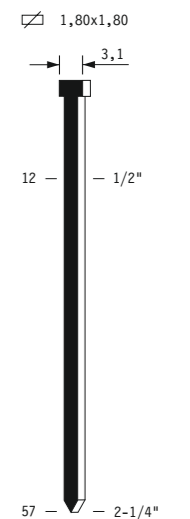

Gauge: 15
Head width: .122"

Funzionamento - Operating mode

Sparo Sequenziale singolo Single sequential actuation



Di serie / Standard

Con dotazioni di serie (grilletto nero)
With standard version (black trigger)

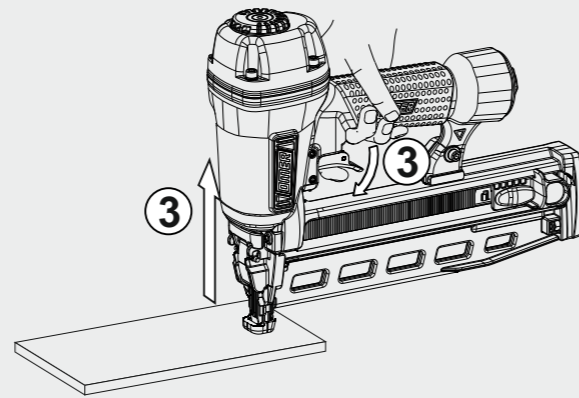
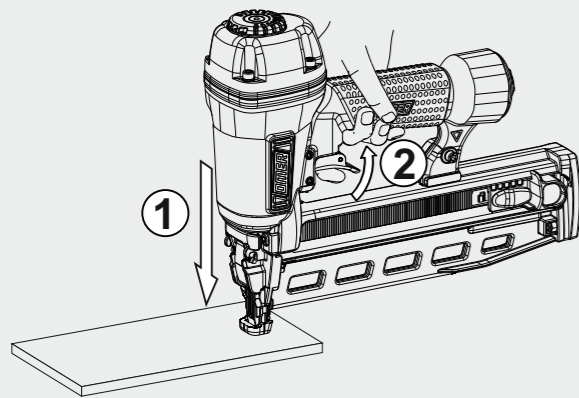

1- Premere la sicura sul materiale da fissare.
Press the safety against the material to be fastened.

3- Rilasciare il grilletto e la sicura
Release trigger and safety

2- Premere il grilletto per sparare.
Press the trigger to fire

4- Ripetere la sequenza per ogni sparo successivo
Repeat the sequence for each subsequent fire

Sparo a martello Bump fire



A richiesta / On request

Con kit sostitutivo 81.78K (grilletto rosso)
With alternative kit 81.78K (red trigger)

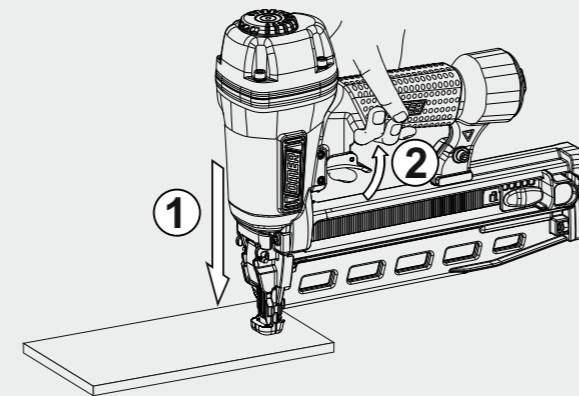
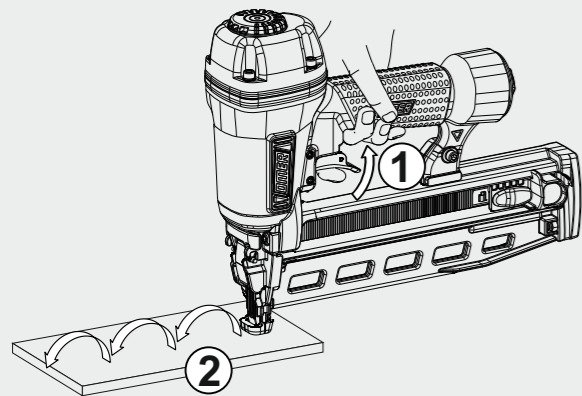

1- Premere il grilletto e mantenerlo premuto.
Press and keep holding the trigger

1- Premere la sicura sul materiale da fissare.
Press the safety against the material to be fastened.

2- Premere la sicura sul materiale da fissare per sparare.
Press the safety against the material to be fastened to fire

2- Premere il grilletto per sparare.
Press the trigger to fire

Parti di ricambio - Spare parts - Ersatzteile - Pièces de rechange - Piezas de repuesto Ανταλλακτικά - Partes sobresselentes - Tabel te raadplegen - Reservedele

Cod.	Descrizione	Description
00.11	O-Ring	O-Ring
00.14	O-Ring	O-Ring
00.15.2	O-Ring	O-Ring
00.18	O-Ring	O-Ring
00.22	O-Ring	O-Ring
00.45	O-Ring	O-Ring
01.35	O-Ring	O-Ring
01.48	O-Ring	O-Ring
01.51	O-Ring	O-Ring
01.64	O-Ring	O-Ring
02.38.2	O-Ring	O-Ring
02.48	O-Ring	O-Ring
03.16.1	Vite	Screw
03.30	Dado	Nut
04.00	Dado	Nut
04.08.2	Vite	Screw
04.14	Vite	Screw
05.00	Dado	Nut
05.20.1	Vite	Screw
05.25	Vite	Screw
05.30	Vite	Screw
06.20.2	Vite	Screw
07.25	Chiave esagonale	Hex. bar wrench
07.30	Chiave esagonale	Hex. bar wrench
07.40	Chiave esagonale	Hex. bar wrench
09.02	Anello elastico	Elastic ring
09.24.1	Anello elastico	Elastic ring
10.55	O-Ring	O-Ring
14.20.1	Spina	Pin
14.25.1	Spina	Pin
17.27	Tappo	Inlet cap
21.75	Corpo	Body
22.74	Testa	Head
25.74	Deflettore scarico	Exhaust deflector
26.74	Cilindro	Cylinder
27.70	Anello	Ring
27.74	Anello cilindro	Cylinder ring
28.74	Guarnizione testa	Head gasket
30.75	Pistone	Piston
32.75.4	Ammortizzatore	Bumper
40.74	Valvola completa	Valve assembled
43.11	Rondella	Washer
44.73	Guarnizione cilindro	Cylinder gasket
44.74	Ammortizzatore sup.	Upper bumper
45.70	Distanziale	Spacer
50.74.1	Pulsante completo	Trigger valve assy
51.74	Boccola servovalvola	Servo valve bushing
53.74	Pistone servovalvola	Servo valve piston
54.83	Pulsante	Trigger valve
55.74	Raccordo pulsante	Trigger valve bush
55.74.1	Raccordo pulsante	Trigger valve bush
59.74.9	Guida punti	Fastener guide
67.73	Distanziale	Spacer
70.74	puntale in gomma	Rubber tip
71.73	Reggicaricatore	Support
75.64	Sicura	Safety
76.70	Regolatore	Regulator
77.78	Guida sicura	Safety guide
78.74	Rinvio sicura	Contact arm
79.71	Pomello	Button
79.73	Guida spingipunto	Pusher guide
80.75	Grilletto testina	Nose plate trigger
81.78	Grilletto comando BF	BF trigger
81.78K	KIT Grilletto comando BF	BF Trigger KIT
81.78.1	Grilletto comando SQ	SQ trigger
83.71	Blocco sicura	Safety stop
86.74	Boccola	Bushing
90.15	Molla	Spring
90.75	Molla	Spring
91.21	Molla	Spring
91.73	Molla	Spring
91.75	Molla	Spring
92.73	Molla	Spring
93.81	Molla	Spring
23.79.28	Battente	Driver
50.70.33	Caricatore	Magazine
73.79.29	Spingipunto	Pusher
83.70.29	Controtestina	Nose
93.70.29	Testina	Nose plate
D01	Bocchetta olio	Oiler
D02	Occhiali protettivi	Protective goggles

Guarnizioni - O-Rings - Dichtungen - Joints - Kit O-Rings - Ασπριγυακια - Kit O-Rings - Pakninger

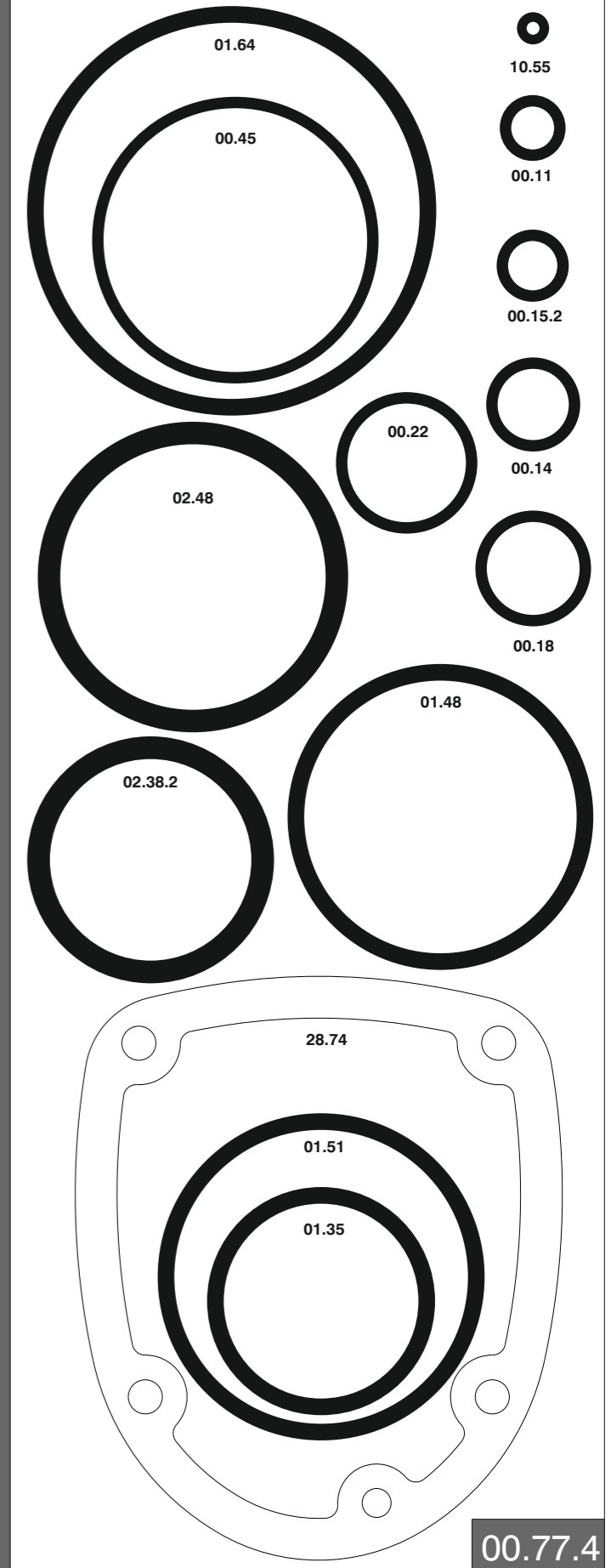

1741790_B17P763_4 270819 IV

B17P.763

cod. 1741790

Indice di modifica
Upgrade number

4

4321605

Dati tecnici - Technical data

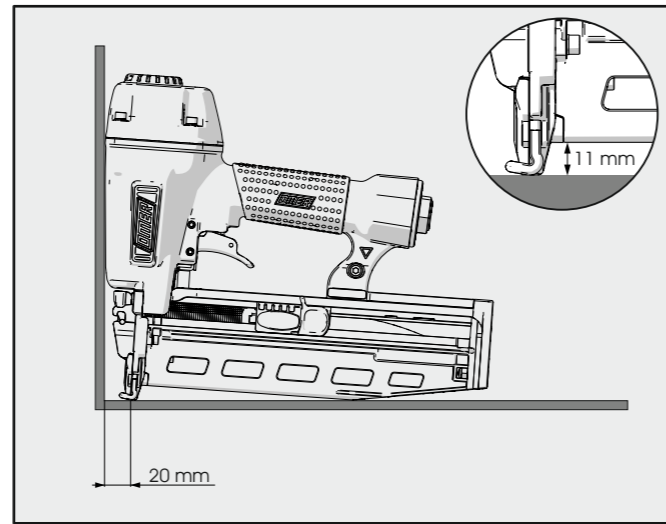
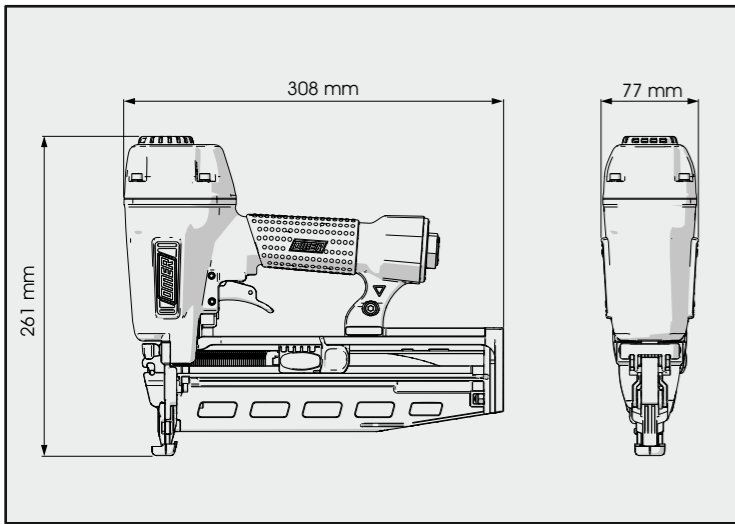

Caricamento - Loading

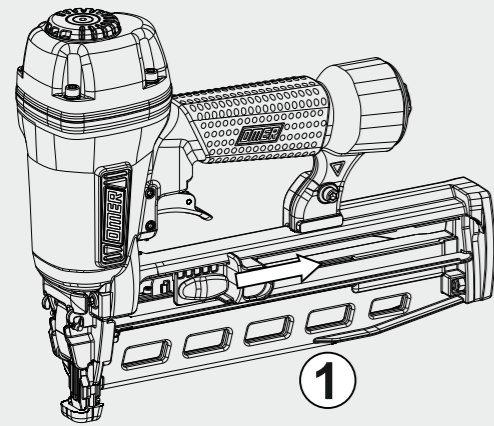

1- Arretrare lo spingipunto fino al finecorsa
Pull the pusher backwards

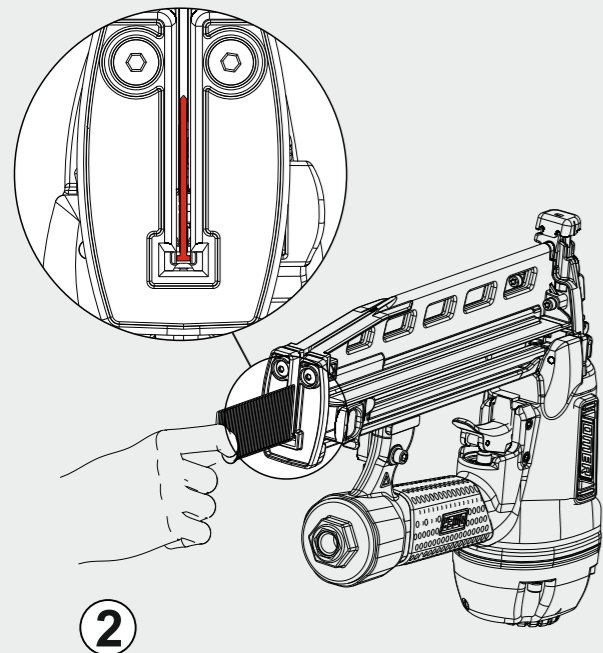

2- Capovolgere la chiodatrice ed inserire i punti
Turn the tool upside down and load fasteners



Non azionare MAI il grilletto comando o la sicura a contatto durante il caricamento.
NEVER pull the trigger or the contact safety while loading magazine.

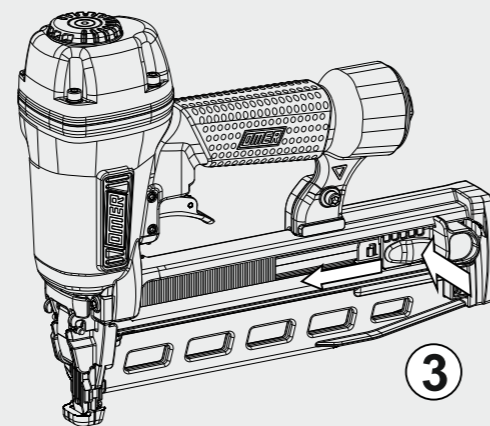

3- Rilasciare lo spingipunto premendo il pulsante di sgancio
Press the releasing button to release the pusher

Regolazione profondità - Depth adjustment

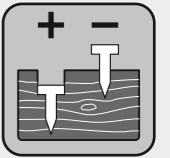
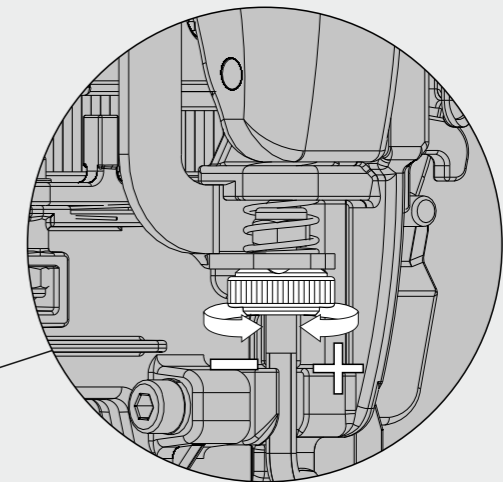
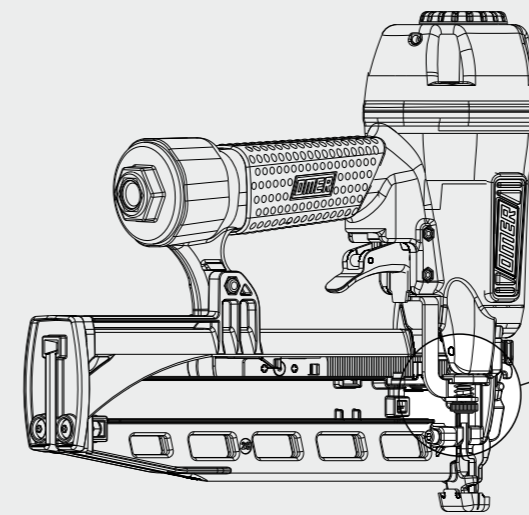

+ Aumenta la penetrazione del punto
Increase fastener penetration

- Diminuisce la penetrazione del punto
Decrease fastener penetration

Disinceppamento - Jam clearing



Scollegare l'aria prima di procedere
Disconnect air supply before proceeding

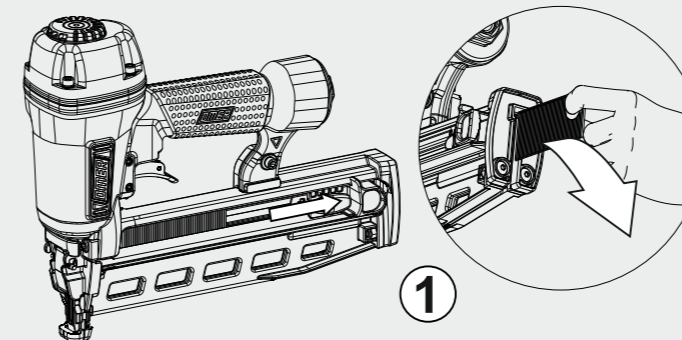

1- Arretrare lo spingipunto fino al finecorsa e rimuovere i punti
Pull the pusher backwards and remove fastener

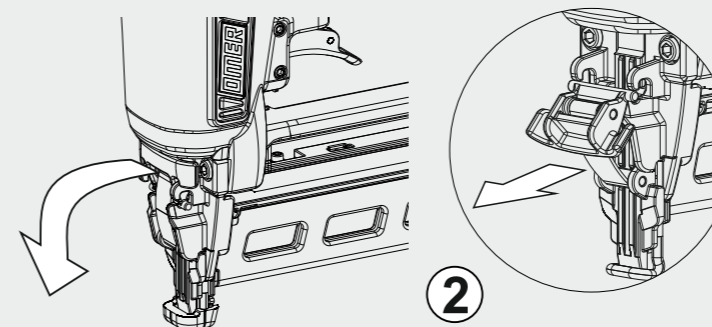

2- Sganciare e rimuovere la testina
Unlock and remove nose plate

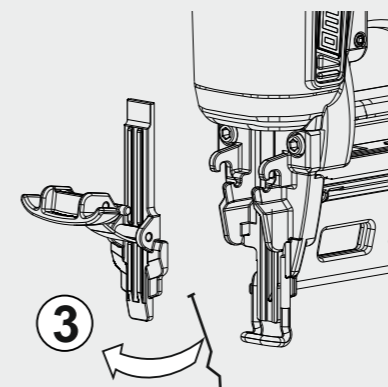

3- Rimuovere il punto inceppato
Remove the jammed nail

4- Riassemblare in ordine inverso ed eseguire il caricamento
Reassemble in reverse order and load with fasteners