

Dati tecnici - Technical data

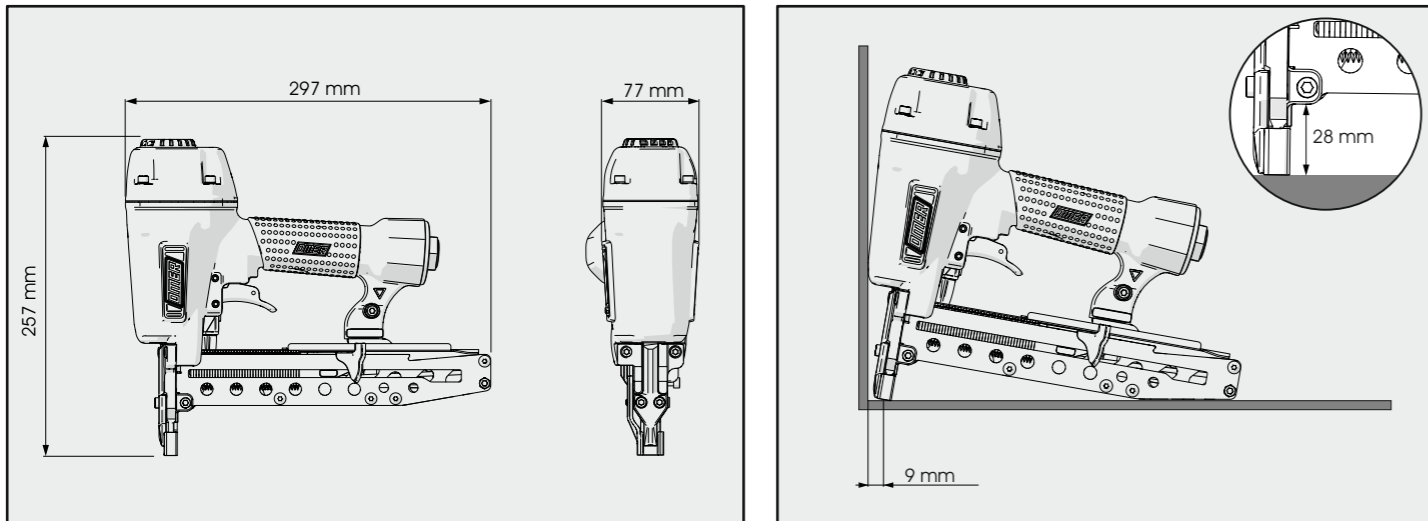

Caratteristiche - Features

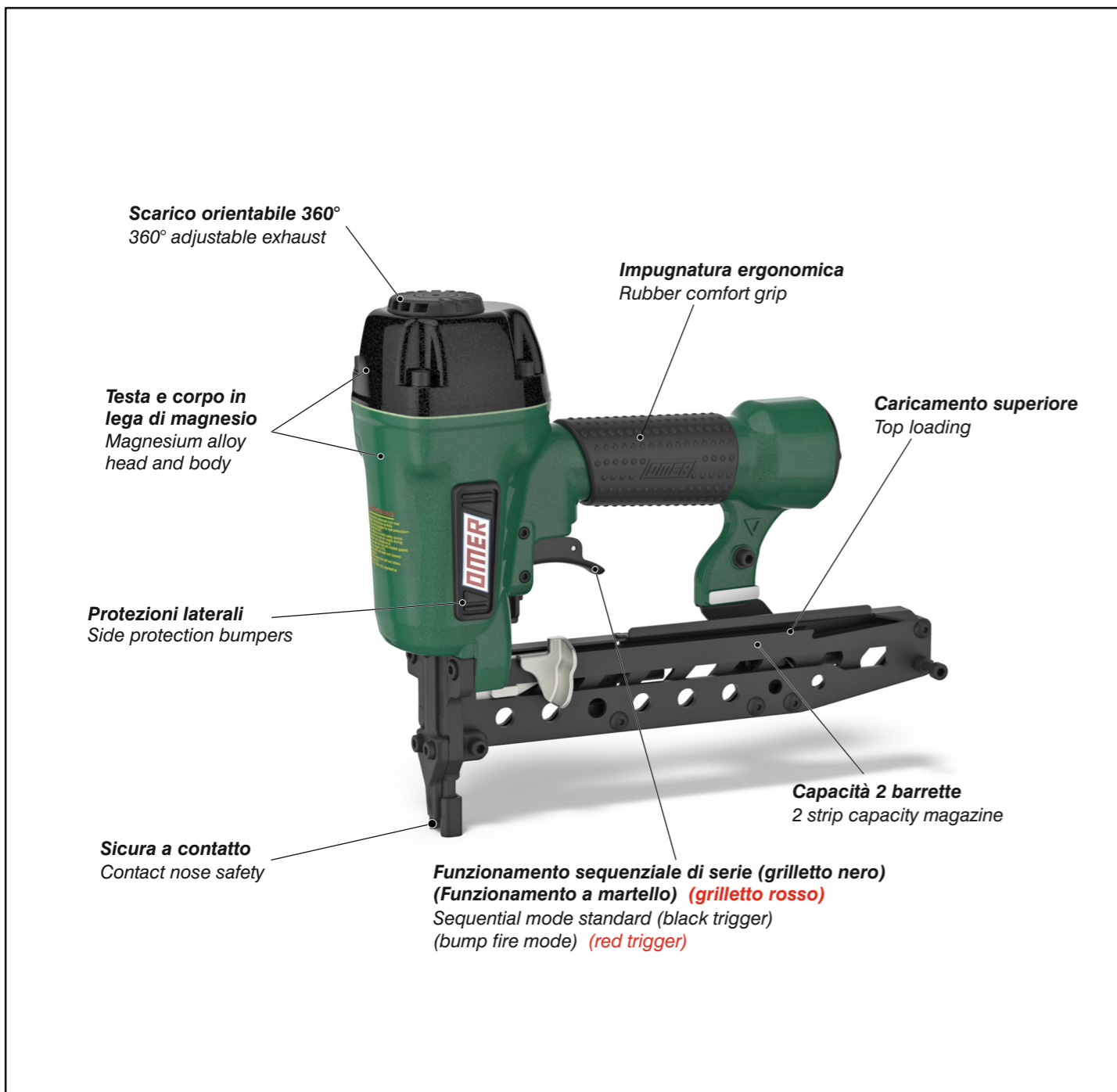

Manuale d'uso, manutenzione e parti di ricambio
Use, maintenance and spare parts manual
Gebrauchsanweisung, Instandhaltungsrichtlinien und Ersatzteile
Manuel d'utilisation, entretien et pièces de rechange
Manual de uso, mantenimiento y repuestos
Εγχειρίδιο χρήσης, συντήρησης και ανταλλακτικών
Manual de utilização, manutenção e partes sobresselentes
Handleiding voor gebruik, onderhoud en reservedeelslijste
Brugsanvisning, vedligeholdelse og reservedelsliste

Parte 2
Part 2
Teil 2
Partie 2
Part 2
2° Μερὸς
Parte 2
Deel 2
Del 2



TN.732

cod. 1741900

1741900_TN732_4 130416 IV

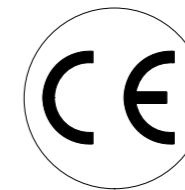

Dati tecnici Technical data Technische daten	Données techniques Datos tècnicos Τεχνικά χαρακτηριστικά	Dados tècnicos Technischegegevens Tekniske data
--	--	---

Misure impiegabili mm Usable lengths mm Gebrauchliche Längen mm	Mesures utilisables mm Medidas que se pueden emplear mm Διαστάσεις σε μμ	Medidas que se podem utilizar mm Te gebruiken lengtes in mm Brugbare laengder i mm	18 ÷ 32
Capacità caricatore n° punti Magazine capacity No. of fasteners Magazinanzahl Nägel	Capacité chargeur n° de points Capacidad cargador n° puntos Διαφοτικότητα γεμιστερα, σωνδετερεσ	Capacidade carregador n° pontos Capaciteit magazijn in aantal spijkers Kapacitet af magasin antal klemme	80
Pressione d'esercizio Working pressure Betriebsdruck	Pression de fonctionnement Presión de trabajo Πίεση λειτουργίας ατμ.	Pressao de trabalho Werkdruk Arbejds tryk bar	5 ÷ 7,5 bar 70 ÷ 105 psi
Consumo aria litri/colpo Air consumption litres/shot Luftverbrauch Liter/Schlag	Consommation air litre/coup Consumo aire-litros/golpe Καταναλοση αερα λ/ξτωπημα	Consumo ar litro/golpe Luchtverbruik liter/schot Luftforbrug liter/skud	0,75
Peso kg Weight kg Gewicht kg	Poids kg Peso kg Βαρος κγ	Peso kg Gewicht in kg Vaegt kg	1,95
Dimensioni (AxBxH) mm Dimensions mm Größe mm	Dimension mm Dimensiones mm Διαφοτικότητα γεμιστερα, σωνδετερεσ	Dimencoes mm Afmetingen in mm Dimensioner mm	295x94x257

EN 12549 :1999	ISO 11201 :1995		
Pressione sonora in pos. operatore Sound pressure at the workstation Lärmintensität am Arbeitsplatz	Pression acoustique près de l'opérateur Presión sonora en posición encargado Ακουστική πίεση στη θέση χειριστού	Intensidade sonora perto do operador Geluidssterkte op de werkplek Lydstyrke på operatorposten	86,1 dB(A)

EN 12549 :1999	ISO 3744 :1994		
Potenza sonora emessa Emitted sound power Ausgestrahlte Lärmintensität	Puissance acoustique émise Potencia sonora emitida Ακουστική ισχυ	Potência sonora emitida Uitgestraalde geluidssterkte Udsendt lydstryke	94,9 dB(A)

EN 28662 :1992	ISO 5349 :1986	ISO 8662 -11	
Valore medio ponderato di vibrazione sull'impugnatura Weighted mean value of vibration on the grip Mittlerer Vibrationswert, am Griff Gemessen	Valeur moyenne pondérée de vibration mesurée sur la poignée Valor medio ponderado de vibracion medida en la empunadura Μεσσοσ οροσ μετρησις κραδασιμον στη χειρολαβη	Valor medio ponderado de vibracao medida no punho Gewogen gemiddelde vibratiewaarde Middellaardi af vibrationer pa handtaget	2,6 m/s²

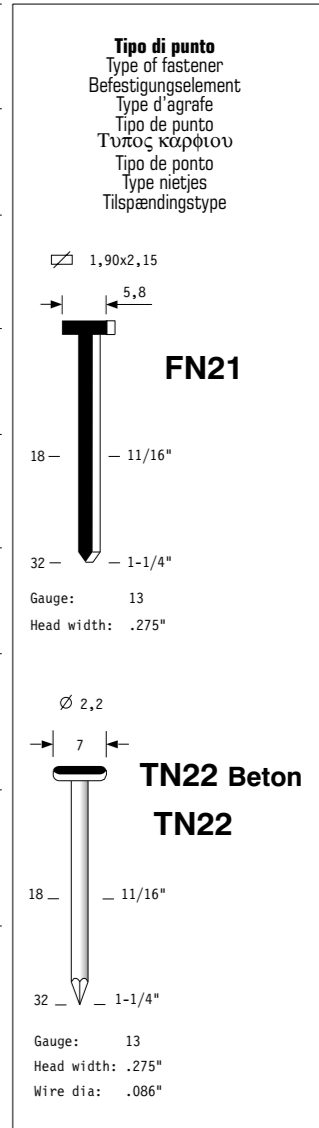

Parti di ricambio - Spare parts - Ersatzteile - Pièces de rechange - Piezas de repuesto
Ανταλλακτικά - Partes sobresselentes - Tabel te raadplegen - Reservededele

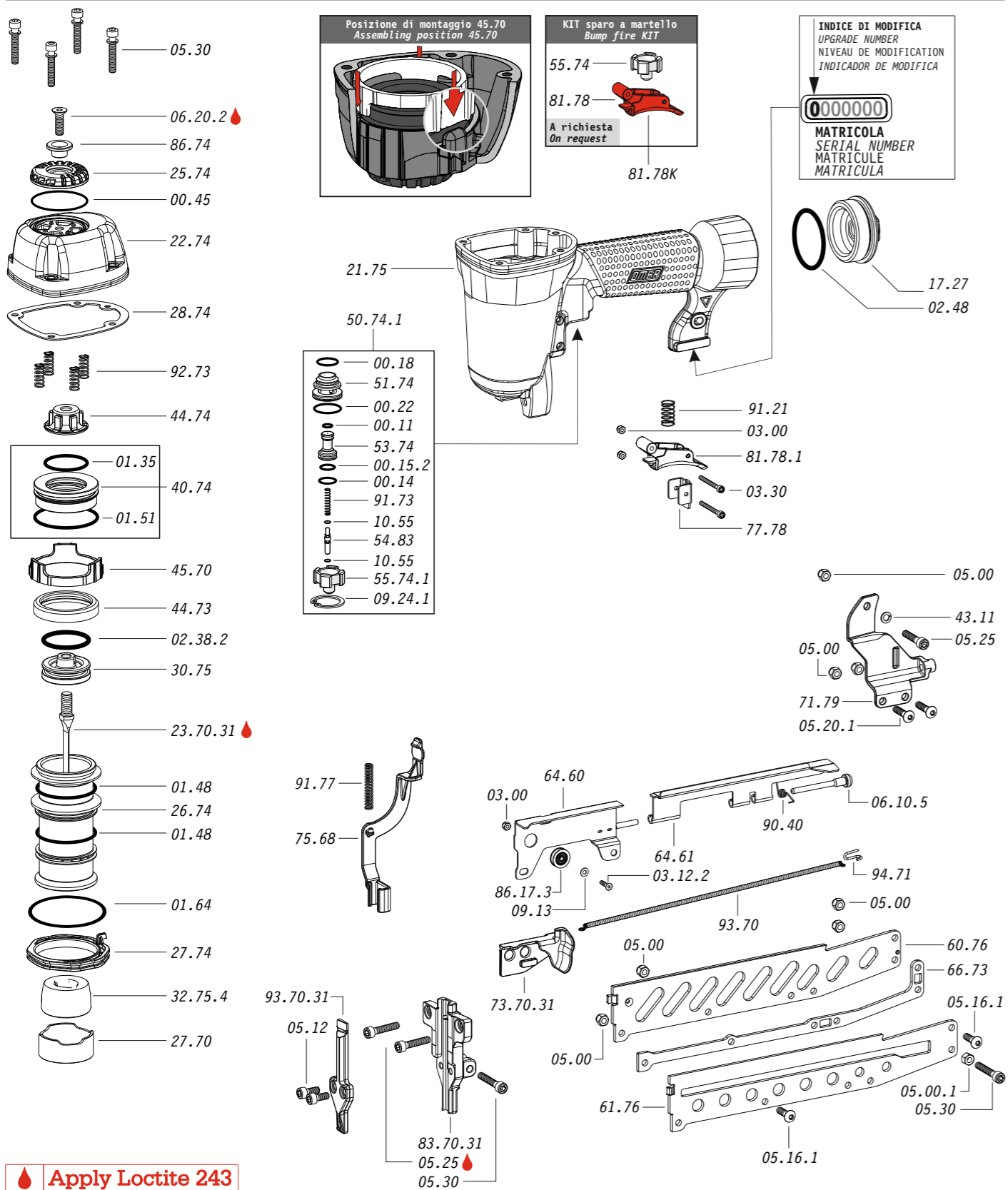

Note - Notes

Dotazioni - Equipment - Ausrüstung - Équipements - Equipamiento - Παρεχόμενα
Equipamento - Uitrusting - Udstyr

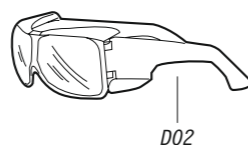
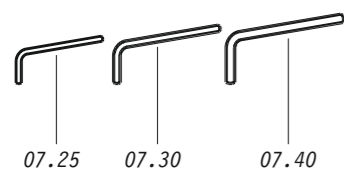

TN.732

cod. 1741900

Funzionamento - Operating mode

Sparo Sequenziale singolo Single sequential actuation



Di serie / Standard

Con dotazioni di serie (grilletto nero)
With standard version (black trigger)

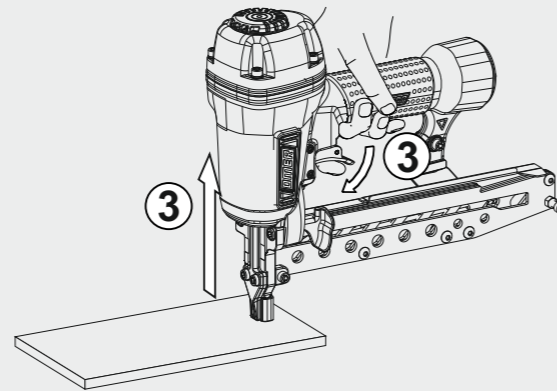
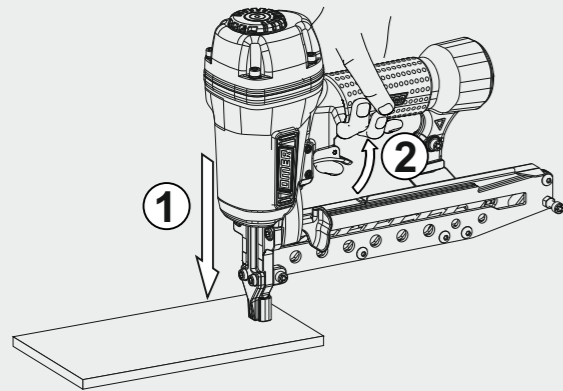

1- Premere la sicura sul materiale da fissare.
Press the safety against the material to be fastened.

3- Rilasciare il grilletto e la sicura
Release trigger and safety

2- Premere il grilletto per sparare.
Press the trigger to fire

4- Ripetere la sequenza per ogni sparo successivo
Repeat the sequence for each subsequent fire

Sparo a martello Bump fire



A richiesta / On request

Con kit sostitutivo 81.78K (grilletto rosso)
With alternative kit 81.78K (red trigger)

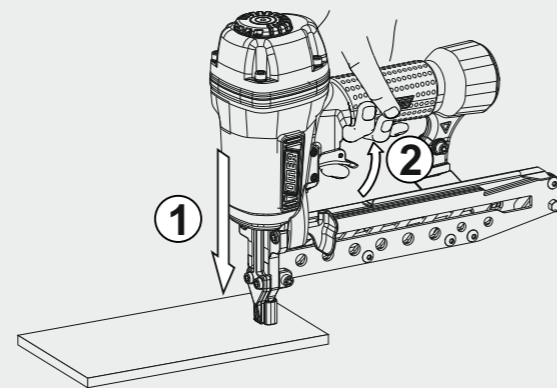
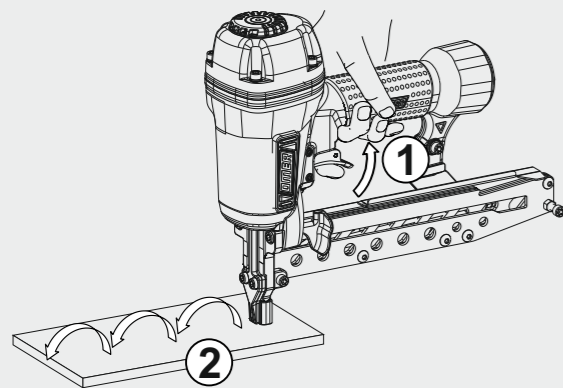

1- Premere il grilletto e mantenerlo premuto.
Press and keep holding the trigger

1- Premere la sicura sul materiale da fissare.
Press the safety against the material to be fastened.

2- Premere la sicura sul materiale da fissare
per sparare.
Press the safety against the material to be
fastened to fire

2- Premere il grilletto per sparare.
Press the trigger to fire

Parti di ricambio - Spare parts - Ersatzteile - Pièces de rechange - Piezas de repuesto Ανταλλακτικά - Partes sobresselentes - Tabel te raadplegen - Reservedele

Cod.	Descrizione	Description
00.11	O-Ring	O-Ring
00.14	O-Ring	O-Ring
00.15.2	O-Ring	O-Ring
00.18	O-Ring	O-Ring
00.22	O-Ring	O-Ring
00.45	O-Ring	O-Ring
01.35	O-Ring	O-Ring
01.48	O-Ring	O-Ring
01.51	O-Ring	O-Ring
01.64	O-Ring	O-Ring
02.38.2	O-Ring	O-Ring
02.48	O-Ring	O-Ring
03.00	Dado	Nut
03.12.2	Vite	Screw
03.30	Vite	Screw
05.00	Dado	Nut
05.00.1	Dado	Nut
05.12	Vite	Screw
05.16.1	Vite	Screw
05.20.1	Vite	Screw
05.25	Vite	Screw
05.30	Vite	Screw
06.10.5	Vite	Screw
06.20.2	Vite	Screw
07.25	Chiave esagonale	Hex. bar wrench
07.30	Chiave esagonale	Hex. bar wrench
07.40	Chiave esagonale	Hex. bar wrench
09.13	Anello elastico	Elastic ring
09.24.1	Anello elastico	Elastic ring
10.55	O-Ring	O-Ring
17.27	Tappo	Inlet cap
21.75	Corpo	Body
22.74	Testa	Head
25.74	Deflettore scarico	Exhaust deflector
26.74	Cilindro	Cylinder
27.70	Anello	Ring
27.74	Anello cilindro	Cylinder ring
28.74	Guarnizione testa	Head gasket
30.75	Pistone	Piston
32.75.4	Ammortizzatore	Bumper
40.74	Valvola completa	Valve assembled
43.11	Rondella	Washer
44.73	Guarnizione cilindro	Cylinder gasket
44.74	Ammortizzatore sup.	Upper bumper
45.70	Distanziale	Spacer
50.74.1	Pulsante completo	Trigger valve assy
51.74	Boccola servovalvola	Servo valve bushing
53.74	Pistone servovalvola	Servo valve piston
54.83	Pulsante	Trigger valve
55.74	Raccordo pulsante	Trigger valve bush
55.74.1	Raccordo pulsante	Trigger valve bush
60.76	Guida Sx	Left Guide
61.76	Guida Dx	Right Guide
64.60	Carter	Guard
64.61	Carter mobile	Guard
66.73	Distanziale	Spacer
71.79	Reggicaricatore	Support
75.68	Sicura	Safety
77.78	Guida sicura	Safety guide
81.78	Grilletto comando BF	BF trigger
81.78K	KIT Grilletto comando BF	BF Trigger KIT
81.78.1	Grilletto comando SQ	SQ trigger
86.74	Boccola	Bushing
90.40	Molla	Spring
91.21	Molla	Spring
91.73	Molla	Spring
92.73	Molla	Spring
93.70	Molla	Spring
94.71	Molla	Spring
23.70.31	Battente	Driver
73.70.31	Spingipunto	Pusher
83.70.31	Controtestina	Nose
93.70.31	Testina	Nose plate
D01	Bocchetta olio	Oiler
D02	Occhiali protettivi	Protective goggles

Guarnizioni - O-Rings - Dichtungen - Joints - Kit O-Rings - Αρσπυκτικά - Kit O-Rings - O-ringen - Pakninger

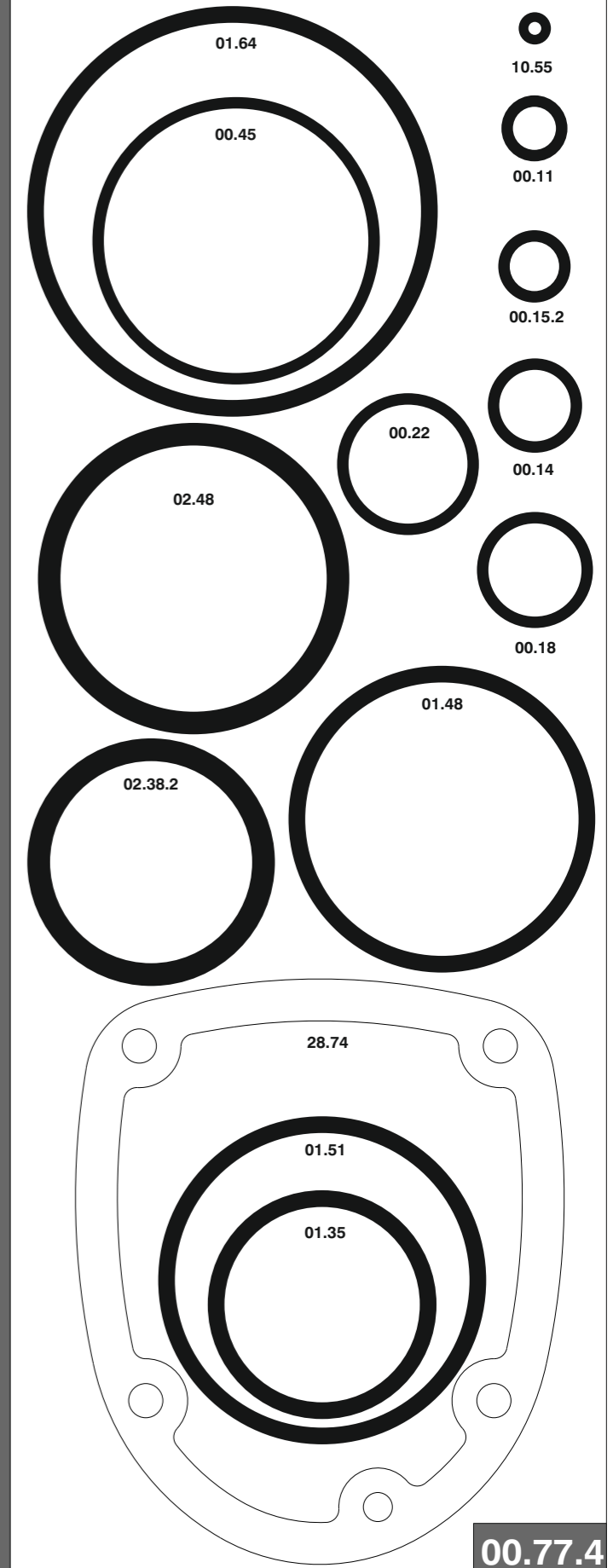

1741900_TN732_4 130416 IV

TN.732

cod. 1741900

Indice di modifica
Upgrade number

4

4361938

Caricamento - Loading



Non azionare MAI il grilletto comando o la sicura a contatto durante il caricamento.
NEVER pull the trigger or the contact safety while loading magazine.

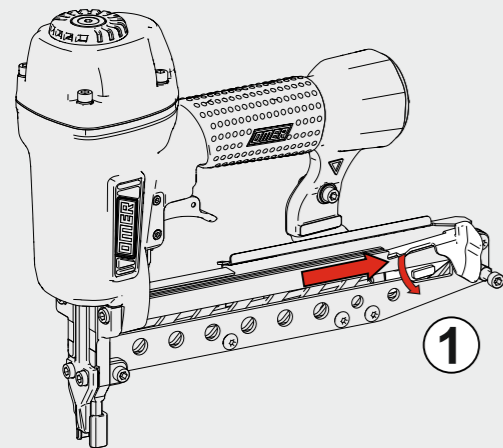

1- Arretrare e agganciare lo spingipunto al fincorsa
Pull the pusher backwards and lock it at the rear of the tool

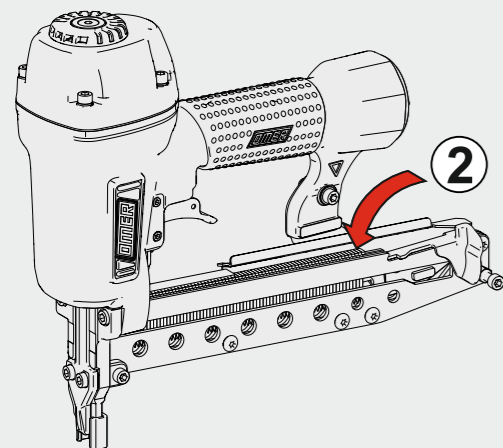

2- Inserire i punti nel caricatore
Load magazine with fasteners

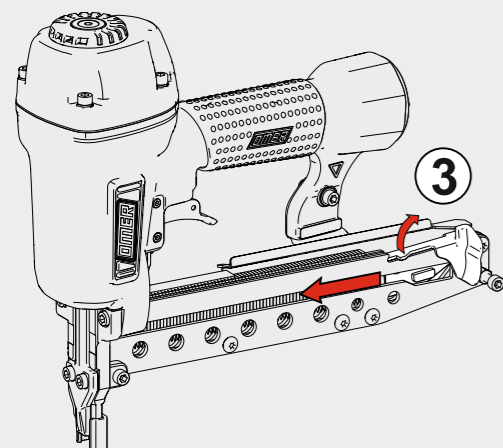

3- Rilasciare lo spingipunto
Release the pusher

Disinceppamento - Jam clearing



Scollegare l'aria prima di procedere
Disconnect air supply before proceeding

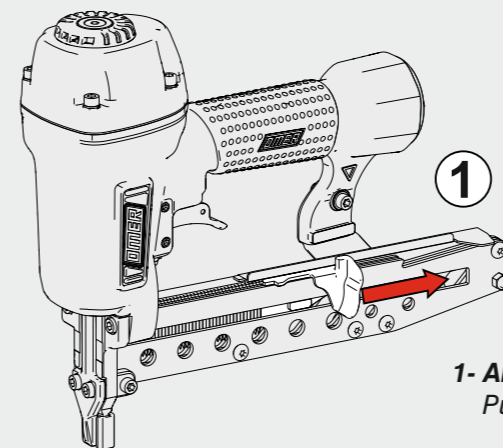

1- Arretrare lo spingipunto fino al fincorsa e rimuovere i punti
Pull the pusher backwards and remove fastener

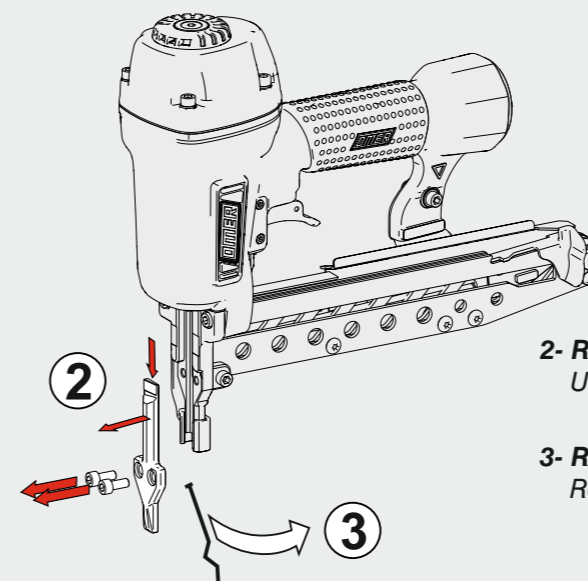

2- Rimuovere le viti e sfilare la testina
Unlock and remove nose plate

3- Rimuovere il punto inceppato
Remove the jammed nail

4- Riassemblare in ordine inverso ed eseguire il caricamento
Reassemble in reverse order and load with fasteners