

## Dati tecnici - Technical data

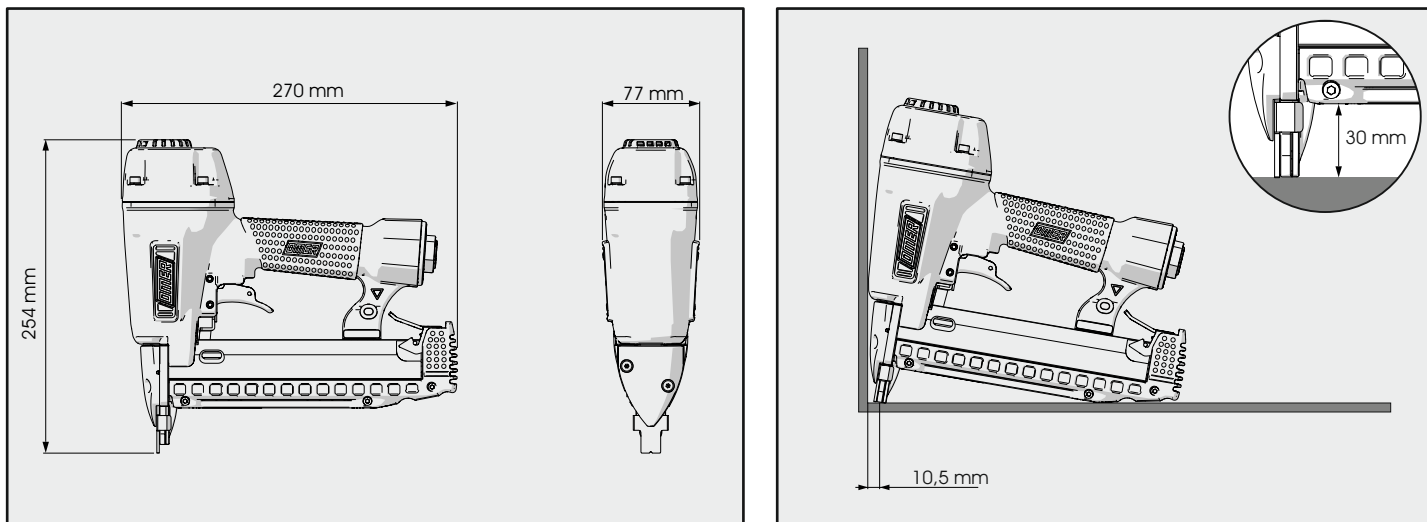

## Caratteristiche - Features



# OMER

**Manuale d'uso, manutenzione e parti di ricambio**  
**Use, maintenance and spare parts manual**  
**Gebrauchsanweisung, Instandhaltungsrichtlinien und Ersatzteile**  
**Manuel d'utilisation, entretien et pièces de rechange**  
**Manual de uso, mantenimiento y repuestos**  
**Εγχειρίδιο χρήσης, συντήρησης και ανταλλακτικών**  
**Manual de utilização, manutenção e partes sobresselentes**  
**Handleiding voor gebruik, onderhoud en reservedeelslijste**  
**Brugsanvisning, vedligeholdelse og reservedeelsliste**

**Parte 2**  
**Part 2**  
**Teil 2**  
**Partie 2**  
**Part 2**  
**2° Μερὸς**  
**Parte 2**  
**Deel 2**  
**Del 2**



# 90.740

1747000\_90740\_4 270514 IV

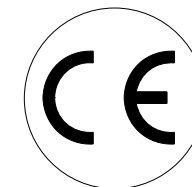

cod. 1747000

Dati tecnici Technical data Technische daten	Données techniques Datos tècnicos Τεχνικά χαρακτηριστικά	Dados tècnicos Technischegegevens Teknische data
----------------------------------------------------	----------------------------------------------------------------	--------------------------------------------------------

<b>Misure impiegabili mm</b> Usable lengths mm Gebrauchliche Längen mm	Mesures utilisable mm Medidas que se pueden emplear mm Διαστάσεις σε μμ	Medidas que se podem utilizar mm Te gebruiken engtes in mm Brugbare laengder i mm	<b>15 ÷ 40</b>
<b>Capacità caricatore n° punti</b> Magazine capacity No. of fasteners Magazinkapazität Nägel	Capacité chargeur n° de points Capacidad cargador n° puntos Δυνατότητα γεμιστέρα, σπινδύτερες	Capacitade carregador n° pontos Capaciteit magazijn in aantal spijkers Kapacitet af magasin antal klemme	<b>110</b>
<b>Pressione d'esercizio</b> Working pressure Betriebsdruck	Pression de fonctionnement Presión de trabajo Πίεση λειτουργίας ατμ.	Pressao de trabalho Werkdruk Arbejds tryk bar	<b>5 ÷ 7,5 bar</b> <b>70 ÷ 105 psi</b>
<b>Consumo aria litri/colpo</b> Air consumption litres/shot Luftverbrauch Liter/Schlag	Consommation air litre/coup Consumo aire-litros/golpe Καταναλοση αερα λ/ξτῶπημα	Consumo ar litro/golpe Luchtverbruik liter/schot Luftforbrug liter/skud	<b>0,75</b>
<b>Peso kg</b> Weight kg Gewicht kg	Poids kg Peso kg Βαρος κγ	Peso kg Gewicht in kg Vaegt kg	<b>1,91</b>
<b>Dimensioni (AxBxH) mm</b> Dimensions mm Größe mm	Dimension mm Dimensiones mm Δυνατότητα γεμιστέρα, σπινδύτερες	Dimencoes mm Afmetingen in mm Dimensioner mm	<b>270x77x254</b>

EN 12549 :1999	ISO 11201 :1995		
<b>Pressione sonora in pos. operatore</b> Sound pressure at the workstation Lärmintensität am Arbeitsplatz	Pression acoustique près de l'opérateur Presión sonora en posición encargado Ακουστική πίεση στη θέση χειριστού	Intensidade sonora perto do operador Geluidssterkte op de werkplek Lydstryke på operatorposten	<b>86,1 dB(A)</b>
EN 12549 :1999	ISO 3744 :1994		
<b>Potenza sonora emessa</b> Emitted sound power Ausgestrahlte Lärmintensität	Puissance acoustique émise Potencia sonora emitida Ακουστική ισχυ	Potência sonora emitida Uitgestraalde geluidssterkte Udsendt lydstryke	<b>94,9 dB(A)</b>

EN 28662 :1992	ISO 5349 :1986	ISO 8662 -11	
<b>Valore medio ponderato di vibrazione sull'impugnatura</b> Weighted mean value of vibration on the grip Mitteler Vibrationswert, am Griff Gemessen	Valeur moyenne pondérée de vibration mesurée sur la poignée Valor medio ponderado de vibracion medida en la empunadura Μεσοσ ορος μετρησις κραδασμων στη χειρολαβη	Valor medio ponderado de vibracao medida no punho Gewogen gemiddelde vibratiewaarde Middelvaerdi af vibrationer pa handtaget	<b>2,6 m/s<sup>2</sup></b>

**Tipo di punto**  
Type of fastener  
Befestigungselement  
Type d'agrafe  
Tipo de punto  
Τυπος κῶρφιου  
Tipo de ponto  
Type nietjes  
Tilspændingstype

**90**

1,00x1,25

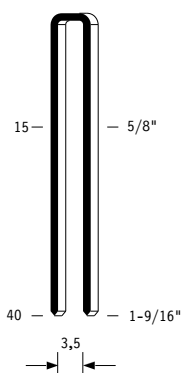

Crown: .217" (1/4")  
Gauge: 18

Parti di ricambio - Spare parts - Ersatzteile - Pièces de rechange - Piezas de repuesto  
Ανταλλακτικά - Partes sobresselentes - Tabel te raadplegen - Reservededele

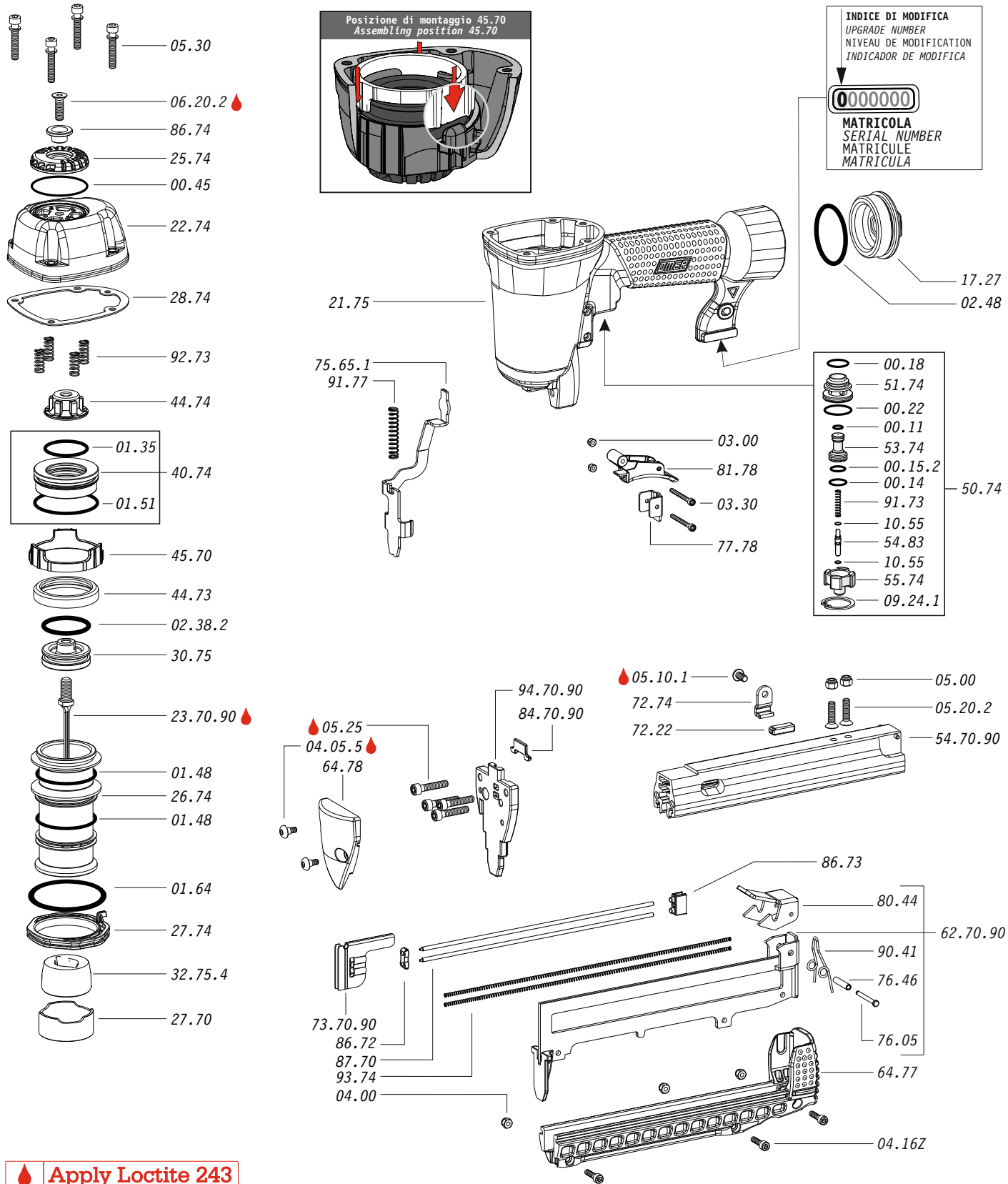

Apply Loctite 243

Dotazioni - Equipment - Ausrüstung - Équipements - Equipamiento - Παρεχόμενα  
Equipamento - Uitrusting - Udstyr

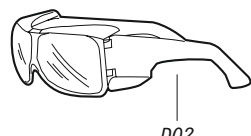
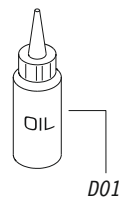
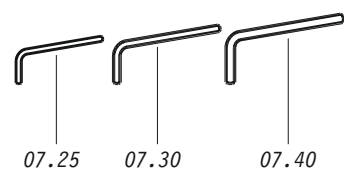

**90.740**

cod. 1747000

Parti di ricambio - Spare parts - Ersatzteile - Pièces de rechange - Piezas de repuesto  
Ανταλλακτικά - Partes sobresselentes - Tabel te raadplegen - Reservededele

Cod.	Descrizione	Description
00.11	O-Ring	O-Ring
00.14	O-Ring	O-Ring
00.15.2	O-Ring	O-Ring
00.18	O-Ring	O-Ring
00.22	O-Ring	O-Ring
00.45	O-Ring	O-Ring
01.35	O-Ring	O-Ring
01.48	O-Ring	O-Ring
01.51	O-Ring	O-Ring
01.64	O-Ring	O-Ring
02.38.2	O-Ring	O-Ring
02.48	O-Ring	O-Ring
03.00	Dado	Nut
03.30	Dado	Nut
04.00	Dado	Nut
04.05.5	Vite	Screw
04.16Z	Vite	Screw
05.00	Dado	Nut
05.10.1	Vite	Screw
05.20.2	Vite	Screw
05.25	Vite	Screw
05.30	Vite	Screw
06.20.2	Vite	Screw
07.25	Chiave esagonale	Hex. bar wrench
07.30	Chiave esagonale	Hex. bar wrench
07.40	Chiave esagonale	Hex. bar wrench
09.24.1	Anello elastico	Elastic ring
10.55	O-Ring	O-Ring
17.27	Tappo	Inlet cap
21.75	Corpo	Body
22.74	Testa	Head
25.74	Deflettore scarico	Exhaust deflector
26.74	Cilindro	Cylinder
27.70	Anello	Ring
27.74	Anello cilindro	Cylinder ring
28.74	Guarnizione testa	Head gasket
30.75	Pistone	Piston
32.75.4	Ammortizzatore	Bumper
40.74	Valvola completa	Valve assembled
44.73	Guarnizione cilindro	Cylinder gasket
44.74	Ammortizzatore sup.	Upper bumper
45.70	Distanziale	Spacer
50.74	Pulsante completo	Trigger valve assy
51.74	Boccola servovalvola	Servo valve bushing
53.74	Pistone servovalvola	Servo valve piston
54.83	Pulsante	Trigger valve
55.74	Raccordo pulsante	Trigger valve bush
64.77	Guida carrello	Slider guide
64.78	Carter sicura	Safety guard
72.22	Fermo carrello	Slider stop
72.74	Fermo di gomma	Rubber stop
75.65.1	Sicura	Safety
76.05	Perno	Pin
76.46	Perno molla	Spring pin
77.78	Guida sicura	Safety guide
80.44	Grilletto chiusura	Trigger
81.78	Grilletto comando BF	BF Trigger
86.72	Guida spingipunto	Pusher guide
86.73	Guida perni	Pin guide
86.74	Boccola	Bushing
87.70	Perno porta molla	Spring guide pin
90.41	Molla	Spring
91.73	Molla	Spring
91.77	Molla	Spring
92.73	Molla	Spring
93.74	Molla	Spring
23.70.90	Battente	Driver
54.70.90	Caricatore	Magazine
62.70.90	Carrello	Slider
73.70.90	Spingipunto	Pusher
84.70.90	Controtestina	Nose
94.70.90	Testina	Nose plate
D01	Bocchetta olio	Oiler
D02	Occhiali protettivi	Protective goggles

Guarnizioni - O-Rings - Dichtungen - Kits - O-Rings - Αρσπυγκία - Kit - O-Rings - Pakninger

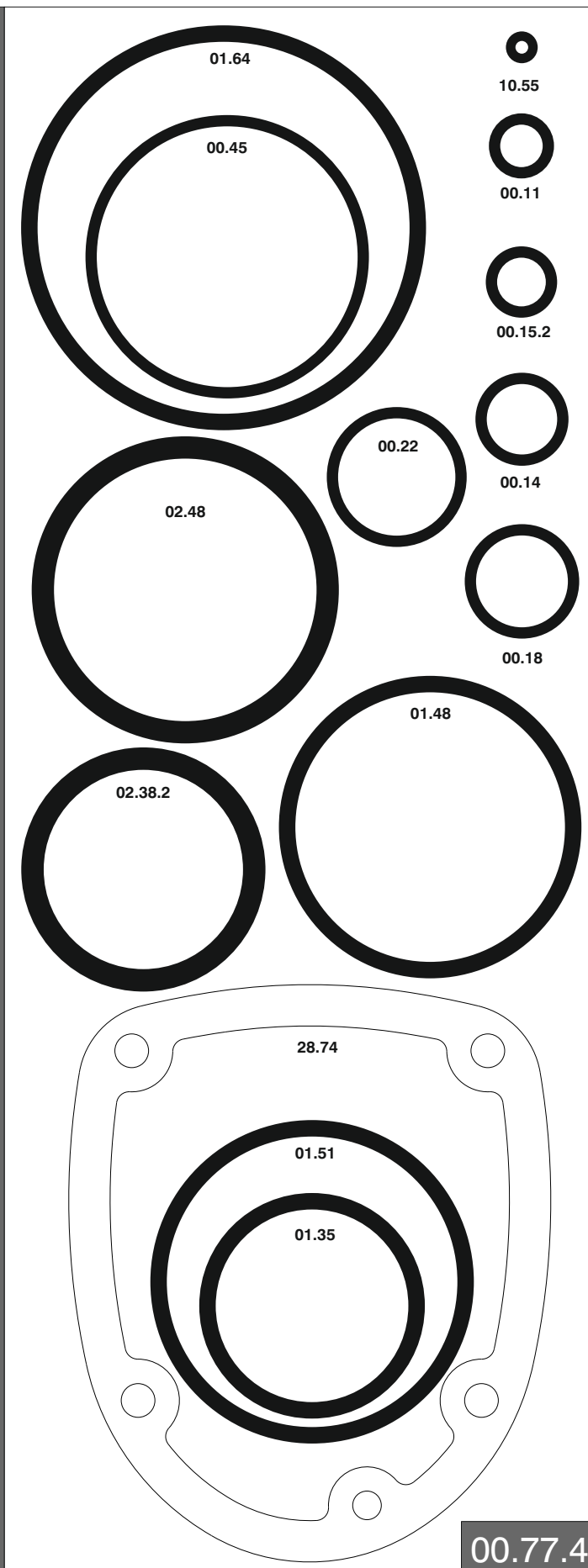

**90.740**

cod. 1747000

Indice di modifica Upgrade number **4**

4313191

1747000\_90740\_4 270514 IV

## Caricamento - Loading

- 1- Premere il grilletto chiusura e arretrare il carrello**  
*Press the magazine latch and pull the slider backwards*

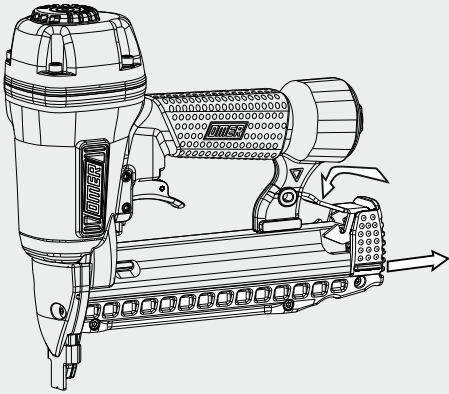

**Non azionare MAI il grilletto comando o la sicura a contatto durante il caricamento.**  
*NEVER pull the trigger or the contact safety while loading magazine.*

- 3- Richiudere il carrello**  
*Shut the slider*

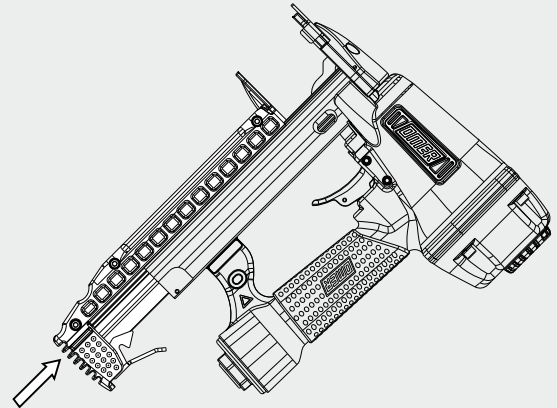

- 2- Capovolgere la graffiatrice ed inserire i punti**  
*Turn the tool up side down and load fasteners*

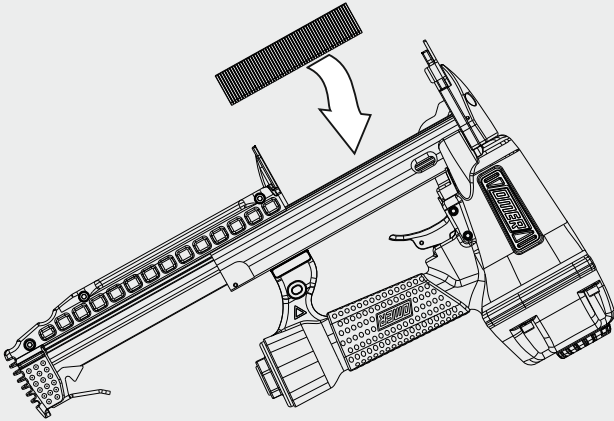

## Funzionamento - Operating mode

### Sparo a martello - Bump fire

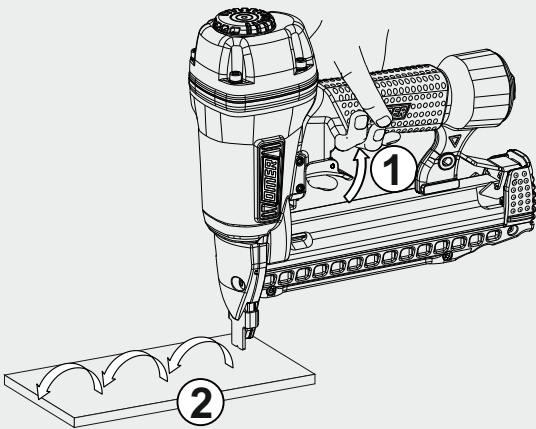

- 1- Premere il grilletto e mantenerlo premuto.**  
*Press and keep holding the trigger*

- 2- Premere la sicura sul materiale da fissare per sparare.**  
*Press the safety against the material to be fastened to fire*

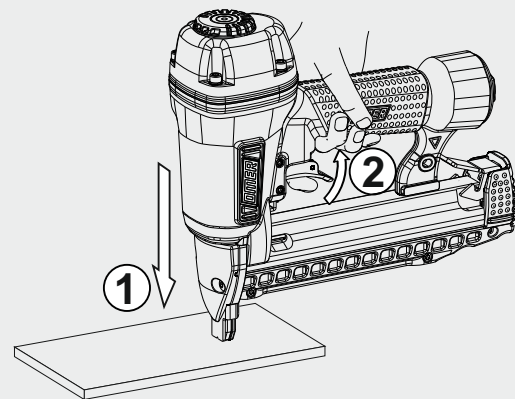

- 1- Premere la sicura sul materiale da fissare.**  
*Press the safety against the material to be fastened.*

- 2- Premere il grilletto per sparare.**  
*Press the trigger to fire*