

Schema di collegamento - Connecting diagram

Collegamento per valvola 3/2 NA

Connection for valve 3/2 NO

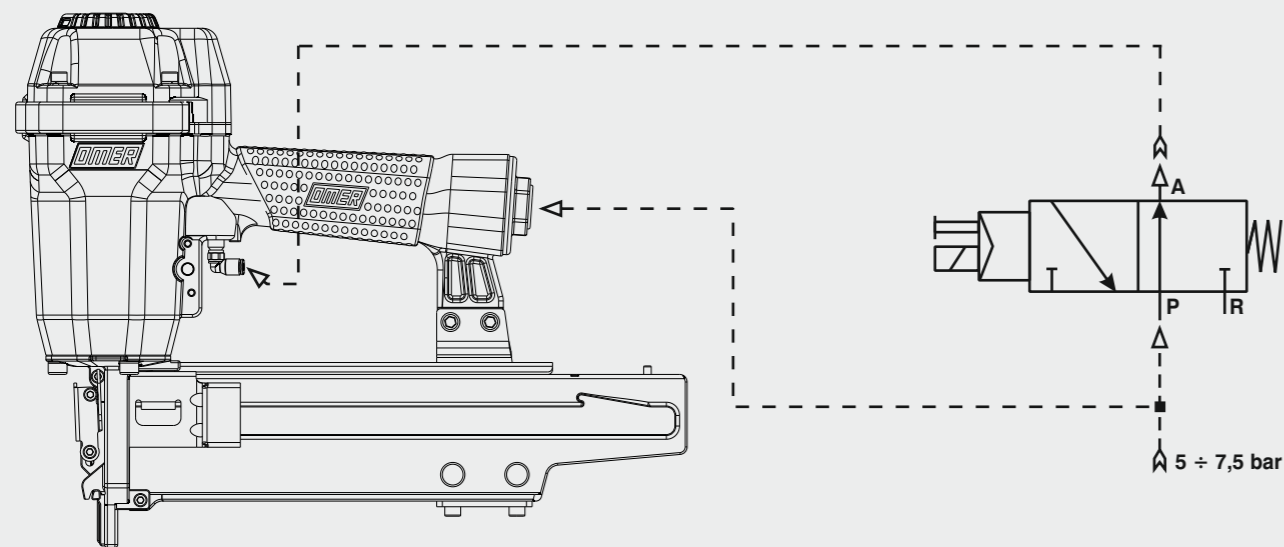

OMER

Manuale d'uso, manutenzione e parti di ricambio

Use, maintenance and spare parts manual

Gebrauchsanweisung, Instandhaltungsrichtlinien und Ersatzteile

Manuel d'utilisation, entretien et pièces de rechange

Manual de uso, mantenimiento y repuestos

Εγχειρίδιο χρήσης, συντήρησης και ανταλλακτικών

Manual de utilização, manutenção e partes sobresselentes

Handleiding voor gebruik, onderhoud en reservedeelslijst

Brugsanvisning, vedligeholdelse og reservedeelsliste

Parte 2

Part 2

Teil 2

Partie 2

Part 2

2^ο Μερὸς

Parte 2

Deel 2

Del 2



M2.65 CD

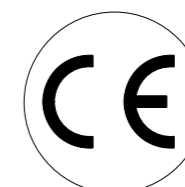

cod. 1848210CD

1848210CD_M265CD_4 300514 IV

Dati tecnici

Technical data
Technische daten

Données techniques

Datos tècnicos
Τεχνικά χαρακτηριστικά

Dados tècnicos

Technische gegevens
Tecnische data

Misure impiegabili mm Usable lengths mm Gebrauchliche Längen mm	Mesures utilisable mm Medidas que se pueden emplear mm Διαστάσεις σε μμ	Medidas que se podem utilizar mm Te gebruiken engtes in mm Brugbare laengder i mm	20 ÷ 65
Capacità caricatore n° punti Magazine capacity No. of fasteners Magazinkapazität Nägel	Capacité chargeur n° de points Capacidad cargador n° puntos Δυνατότητα γεμιστέρα, σπινδύτερες	Capacidade carregador n° pontos Capaciteit magazijn in aantal spijkers Kapacitet af magasin antal klemme	145
Pressione d'esercizio Working pressure Betriebsdruck	Pression de fonctionnement Presión de trabajo Πίεση λειτουργίας ατμ.	Pressao de trabalho Werkdruk Arbejds tryk bar	5 ÷ 7,5 bar 70 ÷ 105 psi
Consumo aria litri/colpo Air consumption litres/shot Luftverbrauch Liter/Schlag	Consommation air litre/coup Consumo aire-litros/golpe Καταναλοση αερα λ/ξτῶπημα	Consumo ar litro/golpe Luchtverbruik liter/schot Luftforbrug liter/skud	1,40

Peso kg Weight kg Gewicht kg	Poids kg Peso kg Βαρος κγ	Peso kg Gewicht in kg Vaegt kg	2,13
---	---------------------------------	--------------------------------------	-------------

Dimensioni (AxBxH) mm Dimensions mm Größe mm	Dimension mm Dimensiones mm Δυνατότητα γεμιστέρα, σπινδύτερες	Dimencoes mm Afmetingen in mm Dimensioner mm	355x98x282
---	---	--	-------------------

EN 12549 :1999 ISO 11201 :1995 Pressione sonora in pos. operatore Sound pressure at the workstation Lärmintensität am Arbeitsplatz	Pression acoustique près de l'opérateur Presión sonora en posición encargado Ακουστική πίεση στη θέση χειριστού	Intensidade sonora perto do operador Geluidssterkte op de werkplek Lydstyrke på operatorposten	$L_{pA,1s}$ (rif. 20μPa) 86,7 dB(A)
---	---	--	--

EN 12549 :1999 ISO 3744 :1994 Potenza sonora emessa Emitted sound power Ausgestrahlte Lärmintensität	Puissance acoustique émise Potencia sonora emitida Ακουστική ισχυ	Potência sonora emitida Uitgestraalde geluidssterkte Udsendt lydstryke	$L_{WA,1s}$ (rif. 1pW) 97,9 dB(A)
---	---	--	--

EN 28662 :1992 ISO 5349 :1986 ISO 8662 -11 Valore medio ponderato di vibrazione sull'impugnatura Weighted mean value of vibration on the grip Mitteler Vibrationswert, am Griff Gemessen	Valeur moyenne pondérée de vibration mesurée sur la poignée Valor medio ponderado de vibracion medida en la empuñadura Μεσος ορος μετρησης κραδασμων στη χειρολαβη	Valor medio ponderado de vibracao medida no punho Gewogen gemiddelde vibratiewaarde Middelvaardi af vibrationer pa handtaget	Bump $a_{h,w}$ 4,75 m/s²
--	--	--	---

Tipo di punto
Type of fastener
Befestigungselement
Type d'agrafe
Tipo de punto
Τυπος κάρφιου
Tipo de ponto
Type nietjes
Tilspændingstype

M2

1,40x1,60

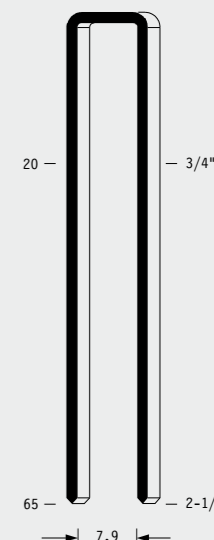

Gauge: 16
Crown: .421" (7/16")

Disinceppamento macchina - Quick clearance jammed nails



Non azionare MAI la valvola di comando durante il caricamento, disinceppamento della graffatrice.
NEVER actuate the command valve while loading magazine or clearing a jammed staple.

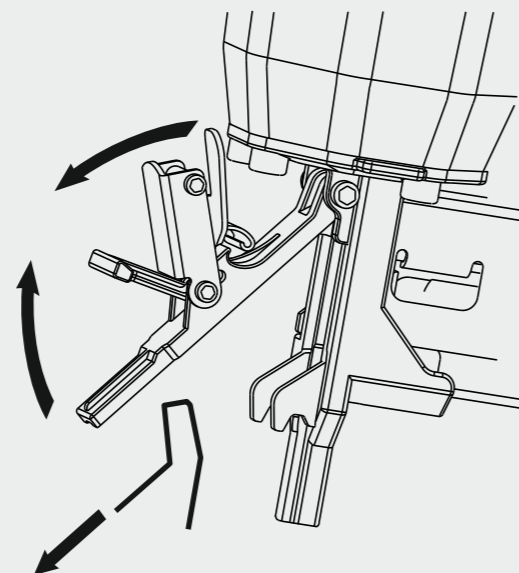

Parti di ricambio - Spare parts - Ersatzteile - Pièces de rechange - Piezas de repuesto
Ανταλλακτικά - Partes sobresselentes - Tabel te raadplegen - Reservedele

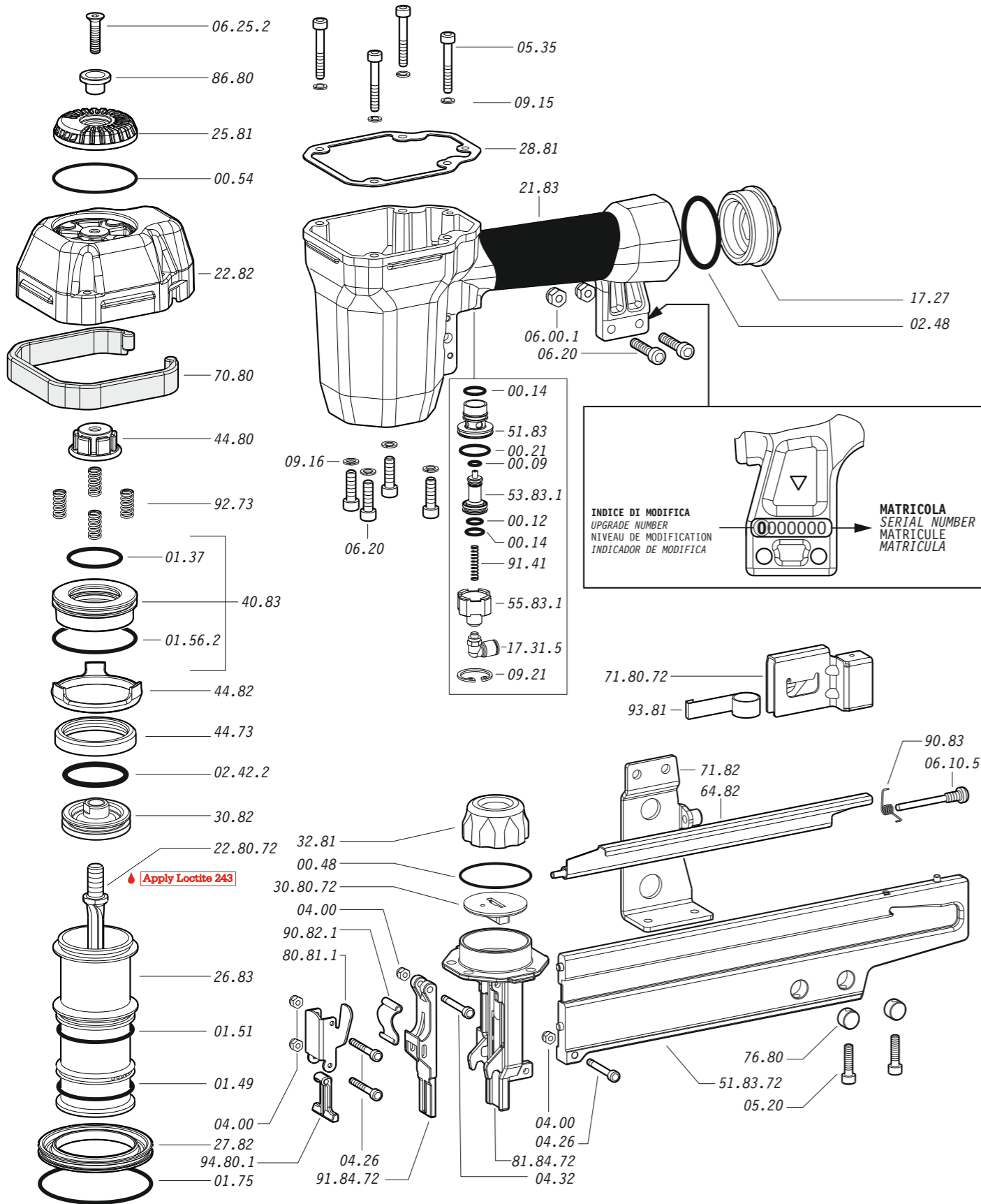

Dotazioni - Equipment - Ausrüstung - Équipements - Equipamiento - Παρεχόμενα Equipamento - Uitrusting - Udstyr



M2.65 CD

cod. 1848210CD

Parti di ricambio - Spare parts - Ersatzteile - Pièces de rechange - Piezas de repuesto
Ανταλλακτικά - Partes sobresselentes - Tabel te raadplegen - Reservedele

Cod.	Descrizione	Description
00.09	O-Ring	O-Ring
00.12	O-Ring	O-Ring
00.14	O-Ring	O-Ring
00.21	O-Ring	O-Ring
00.48	O-Ring	O-Ring
00.54	O-Ring	O-Ring
01.37	O-Ring	O-Ring
01.49	O-Ring	O-Ring
01.51	O-Ring	O-Ring
01.56.2	O-Ring	O-Ring
01.75	O-Ring	O-Ring
02.42.2	O-Ring	O-Ring
02.48	O-Ring	O-Ring
04.00	Dado	Nut
04.26	Vite	Screw
04.32	Vite	Screw
05.20	Vite	Screw
05.35	Vite	Screw
06.00.1	Dado	Nut
06.10.5	Vite	Screw
06.20	Vite	Screw
06.25.2	Vite	Screw
07.30	Chiave esagonale	Hex. bar wrench
07.40	Chiave esagonale	Hex. bar wrench
07.50	Chiave esagonale	Hex. bar wrench
09.15	Rondella	Washer
09.16	Rondella	Washer
09.21	Anello elastico	Elastic ring
17.27	Tappo	Inlet cap
17.31.5	Raccordo	Air plug
21.83	Corpo	Body
22.82	Testa	Head
25.81	Deflettore	Deflector
26.83	Cilindro	Cylinder
27.82	Anello cilindro	Cylinder ring
28.81	Guarnizione testa	Head gasket
30.82	Pistone	Piston
32.81	Ammortizzatore	Bumper
40.83	Valvola completa	Valve ass'y
44.73	Guarnizione cilindro	Cylinder gasket
44.80	Ammortizzatore	Bumper
44.82	Distanziale	Spacer
51.83	Boccola pulsante	Trigger valve housing
53.83.1	Pistone servovalvola	Valve piston
55.83.1	Raccordo pulsante	Bush
64.82	Carter	Hold down
70.80	Protezione	Guard
71.82	Reggicaricatore	Support
76.80	Inserto	Nut screw
80.81.1	Grilletto testina	Nose plate lock
86.80	Boccola	Bush
90.82.1	Molla	Spring
90.83	Molla	Spring
91.21	Molla	Spring
92.73	Molla	Spring
93.81	Molla	Spring
94.80.1	Tirante	Connecting rod
22.80.72	Battente	Driver
30.80.72	Guida battente	Driver Guide
51.83.72	Caricatore	Magazine
71.80.72	Spingipunto	Pusher
81.84.72	Controtestina	Nose
91.84.72	Testina	Nose plate
D01	Bocchetta olio	Oiler
D02	Occhiali protettivi	Protective goggles

Guarnizioni - O-Rings - Dichtungen - Kits - O-Rings - Λαστιχάκια - Kit - O-Rings - Pakninger

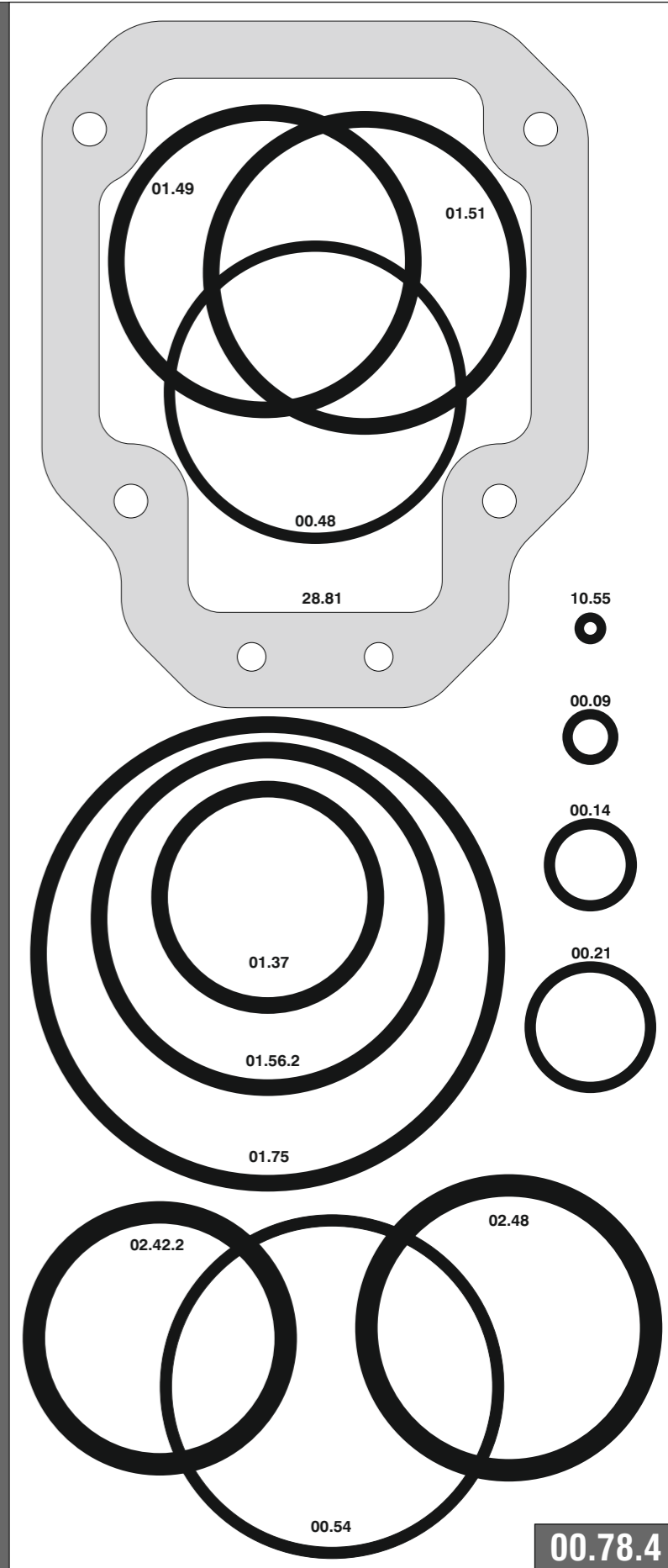

1848210CD_M265CD_4_300514_IV

M2.65 CD

cod. 1848210CD

Indice di modifica
Upgrade number

4

4350570