

Azionamento a contatto

Contact actuation

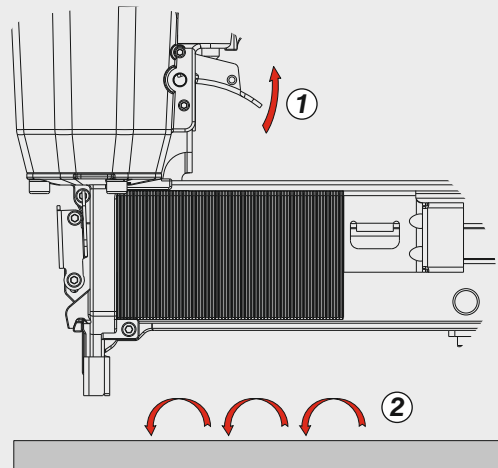

Oppure - Or

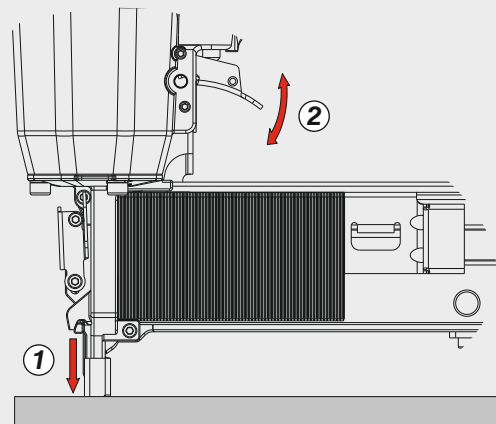

Caricamento - Loading - Laden - Chargement - Carga - Γέμισμα - Carregamento - Laden - Yükleme

Caricamento da sopra

Top load magazine

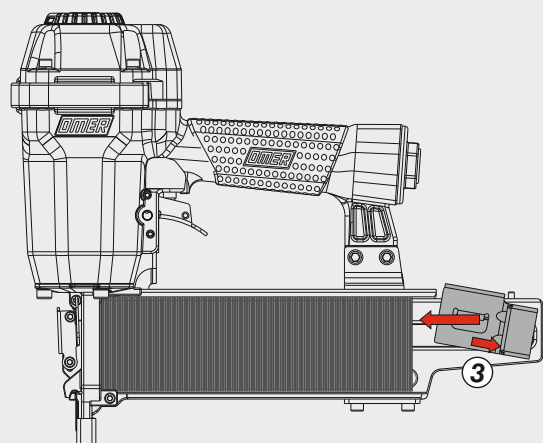
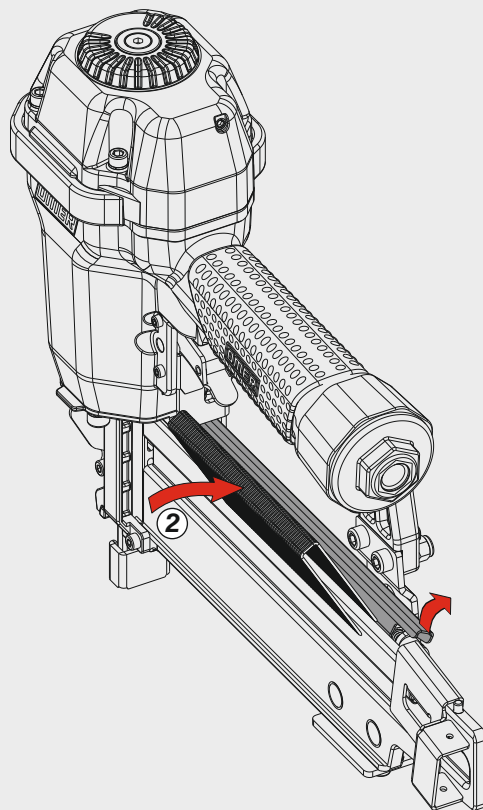
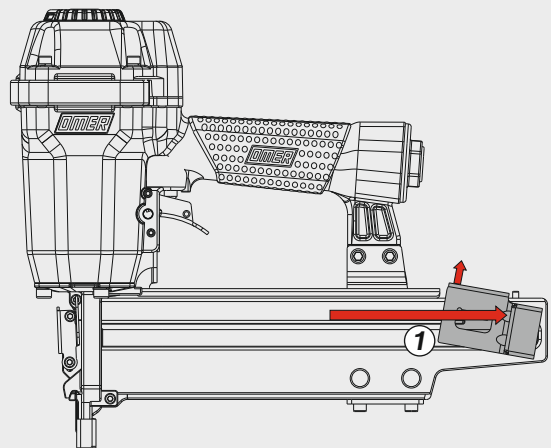

Manuale d'uso, manutenzione e parti di ricambio	Parte 2
Manual for use, maintenance and spare parts	Part 2
Bedienungs- und Wartungshandbuch sowie Ersatzteilleiste	Teil 2
Mode d'emploi, de maintenance et pièces de rechange	Partie 2
Manual de uso, mantenimiento y recambios	Part 2
Εγχειρίδιο χρήσης, συντήρησης και ανταλλακτικών	Μέρος 2
Manual de uso, manutençao e peças sobresselentes	Parte 2
Handleiding voor gebruik, onderhoud en wisselstukken	Deel 2
Kullanım, bakım ve yedek parça kılavuzu	Kısım 2



700.65

cod. 1848310



Warning: Please read the instructions and warnings for this tool carefully before use. Failure to do so could lead to serious injury.

Dati tecnici Technical data Technische Daten	Caractéristiques techniques Datos técnicos Τεχνικά χαρακτηριστικά	Dados técnicos Technische gegevens Teknik veriler	
Misure impiegabili mm Lengths mm Verwendbare Nagellänge mm	Dimensions utiles mm Medidas de longitud mm Μήκος Αναλωσίμου - mm	Medidas utilizáveis mm Toepasbare afmetingen mm Boy mm	20 ÷ 65
Capacità caricatore n° punti Magazine capacity Magazinkapazität Nägel	Capacité chargeur n° de points Capacidad cargador n° puntos Δωανατοτητα γεμιστερα	Capacidade carregador n° pontos Capaciteit magazijn in aantal spijkers Dergi kapasitesi	145
Pressione d'esercizio Operating pressure Betriebsdruck	Pression d'exercice Presión de servicio Πίεση λειτουργίας	Pressão de serviço Werkdruk Çalışma basıncı	5 ÷ 7,5 bar 70 ÷ 105 psi
Consumo aria litri/colpo Air consumption litres/stroke Luftverbrauch Liter/Schuss	Consommation d'air litres/coup Consumo aire litros/golpe Κατανάλωση αέρα - λίτρα/βολή	Consumo ar litros/disparo Luchtverbruik liter/slag Litre/vuruş hava tüketimi	1,40
Peso kg Weight kg Gewicht kg	Poids kg Peso kg Βάρος - kg	Peso kg Gewicht in kg Ağırlık kg	2,14
Dimensioni mm Dimensions mm Abmessungen mm	Dimensions mm Dimensiones mm Διαστάσεις mm	Dimensões mm Afmetingen mm Boyutlar mm	355x98x290 (LxWxH)
UNI EN 12549 :2009 UNI EN ISO 4871 :2009			
Pressione sonora in pos. operatore Sound pressure in operator's position Schalldruck am Arbeitsplatz	Pression sonore poste Opérateur Presión sonora en la pos. del operador Ηχητική πίεση στη θέση του Χειριστή	Pressão sonora na posição Operador Geluidsdruck op de werkplaats Operatör pozisyonunda ses basıncı	91 dB(A) (K= 4 dB)
UNI EN 12549 :2009 UNI EN ISO 3746 :2011 UNI EN ISO 4871 :2009			
Potenza sonora emessa Sound power emitted Emittierte Schalleistung	Puissance sonore émise Potencia sonora emitida Εκπεμπόμενη ηχητική ισχύς	Potência sonora emitida Geëmitteerd geluidsvermogen Çıkan ses gücü (ses desibel)	98 dB(A) (K= 4 dB)
UNI CEN ISO/TS 8662-11 :2006 UNI EN ISO 5349-2 :2004 UNI EN 12096 :1999			
Emissione vibratoria sull'impugnatura Vibratory emissions on handle Vibrationsemission am Griff	Émission vibratoire sur la prise en main Emisión de vibraciones en la empuñadura Εκπεμπόμενες δονήσεις στη λαβή	Emissão vibratória na empunhadura Trillingsemissie op de handgreep Tutamak üzerinde vibrasyon emisyonları	4,55 m/s² (K= 2 m/s ²)

Tipo di punto
Type of fastener
Befestigungsmittel
Type de rivet
Tipo de punto
Τύπος αναλωσίμου
Tipo de agrafa
Type nietjes
Zimba ve çivi tipleri

700

1,40x1,60

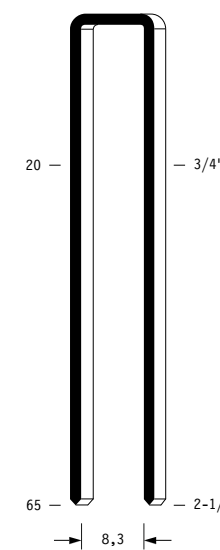

Crown: .437" (7/16")
Gauge: 16

Parti di ricambio - Spare parts - Ersatzteile - Pièces de rechange - Recambios
Ανταλλακτικά - Partes sobresselentes - Wisselstukken - Yedek parçalar

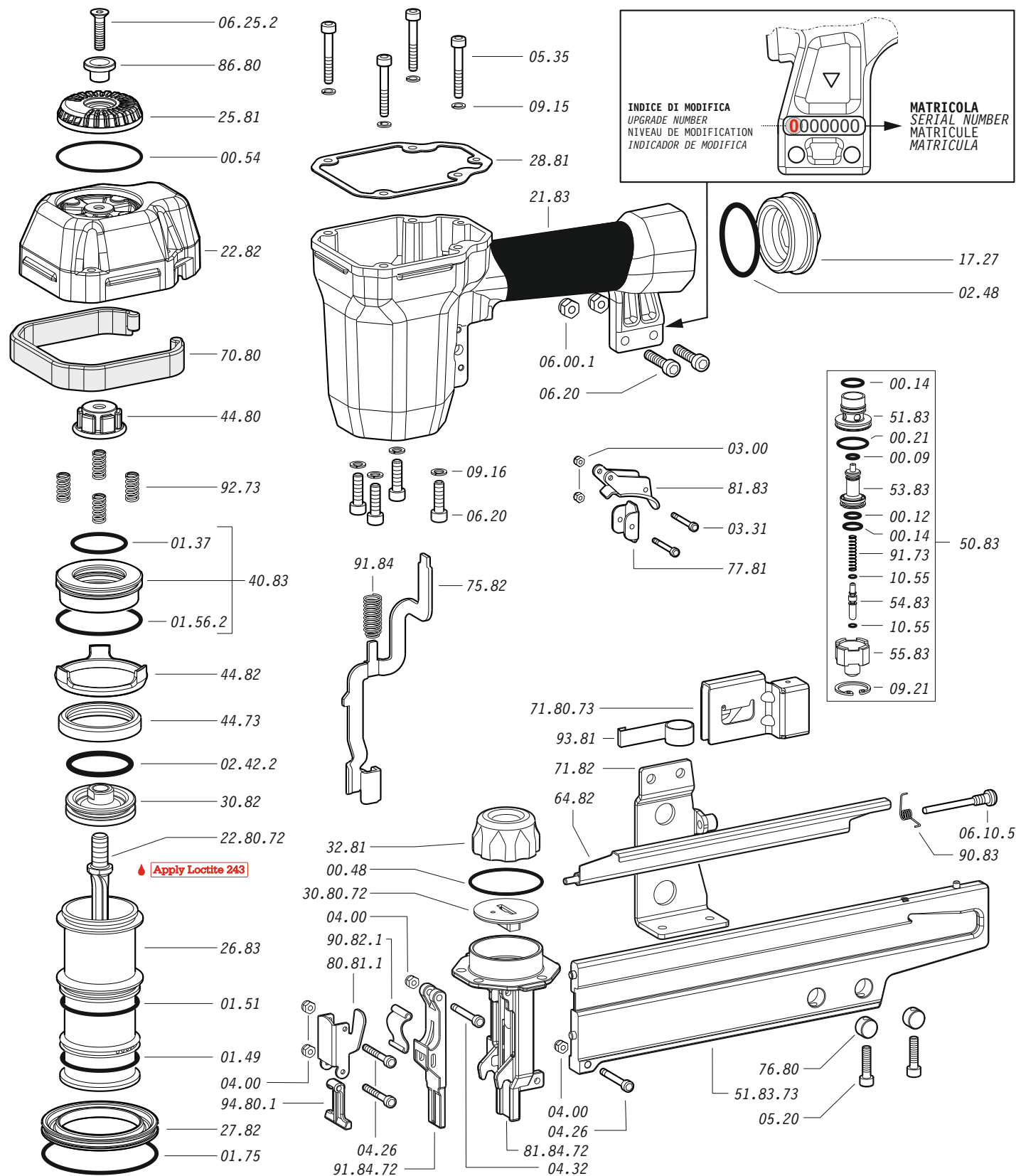

Dotazioni - Equipment - Ausstattung - Outillage - Dotaciones - Εξοπλισμός
Dotações - Uitrusting - Donanımlar

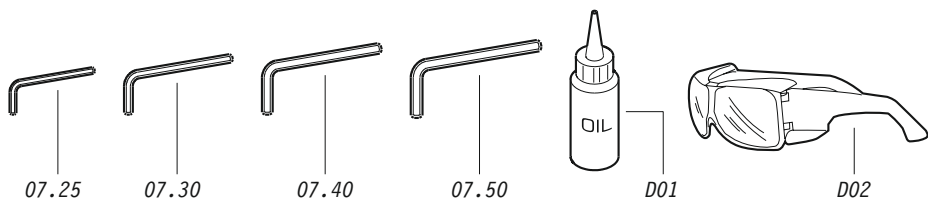

700.65

cod. 1848310

Parti di ricambio - Spare parts - Ersatzteile - Pièces de rechange - Recambios
Ανταλλακτικά - Partes sobresselentes - Wisselstukken - Yedek parçalar

Cod.	Descrizione	Description
00.09	O-Ring	O-Ring
00.12	O-Ring	O-Ring
00.14	O-Ring	O-Ring
00.21	O-Ring	O-Ring
00.48	O-Ring	O-Ring
00.54	O-Ring	O-Ring
01.37	O-Ring	O-Ring
01.49	O-Ring	O-Ring
01.51	O-Ring	O-Ring
01.56.2	O-Ring	O-Ring
01.75	O-Ring	O-Ring
02.42.2	O-Ring	O-Ring
02.48	O-Ring	O-Ring
03.00	Dado	Nut
03.31	Vite	Screw
04.00	Dado	Nut
04.26	Vite	Screw
04.32	Vite	Screw
05.20	Vite	Screw
05.35	Vite	Screw
06.00.1	Dado	Nut
06.10.5	Vite	Screw
06.20	Vite	Screw
06.25.2	Vite	Screw
07.25	Chiave esagonale	Hex. bar wrench
07.30	Chiave esagonale	Hex. bar wrench
07.40	Chiave esagonale	Hex. bar wrench
07.50	Chiave esagonale	Hex. bar wrench
09.15	Rondella	Washer
09.16	Rondella	Washer
09.21	Anello elastico	Elastic ring
10.55	O-Ring	O-Ring
17.27	Tappo	Inlet cap
21.83	Corpo	Body
22.82	Testa	Head
25.81	Deflettore	Deflector
26.83	Cilindro	Cylinder
27.82	Anello cilindro	Cylinder ring
28.81	Guarnizione testa	Head gasket
30.82	Pistone	Piston
32.81	Ammortizzatore	Bumper
40.83	Valvola completa	Valve ass'y
44.73	Guarnizione cilindro	Cylinder gasket
44.80	Ammortizzatore	Bumper
44.82	Distanziale	Spacer
50.83	Pulsante completo	Trigger valve ass'y
51.83	Boccola pulsante	Trigger valve housing
53.83	Pistone servovalvola	Valve piston
54.83	Pulsante	Trigger valve
55.83	Raccordo pulsante	Bush
64.82	Carter	Hold down
70.80	Protezione	Guard
71.82	Reggicaricatore	Support
75.82	Sicura	Safety
76.80	Inserito	Nut screw
77.81	Guida sicura	Safety guide
80.81.1	Grilletto testina	Nose plate lock
81.83	Grilletto comando	Trigger
86.80	Boccola	Bush
90.82.1	Molla	Spring
90.83	Molla	Spring
91.73	Molla	Spring
91.84	Molla	Spring
92.73	Molla	Spring
93.81	Molla	Spring
94.80.1	Tirante	Connecting rod
22.80.72	Battente	Driver
30.80.72	Guida battente	Driver Guide
51.83.73	Caricatore	Magazine
71.80.73	Spingipunto	Pusher
81.84.72	Controtestina	Nose
91.84.72	Testina	Nose plate
D01	Bocchetta olio	Oiler
D02	Occhiali protettivi	Protective goggles

700.65

cod. 1848310

Guarnizioni - O-Rings - Dichtungen - Juntas - Δακτύλιος στεγανοποίησης - Vedantes - O-ringen - Contalar

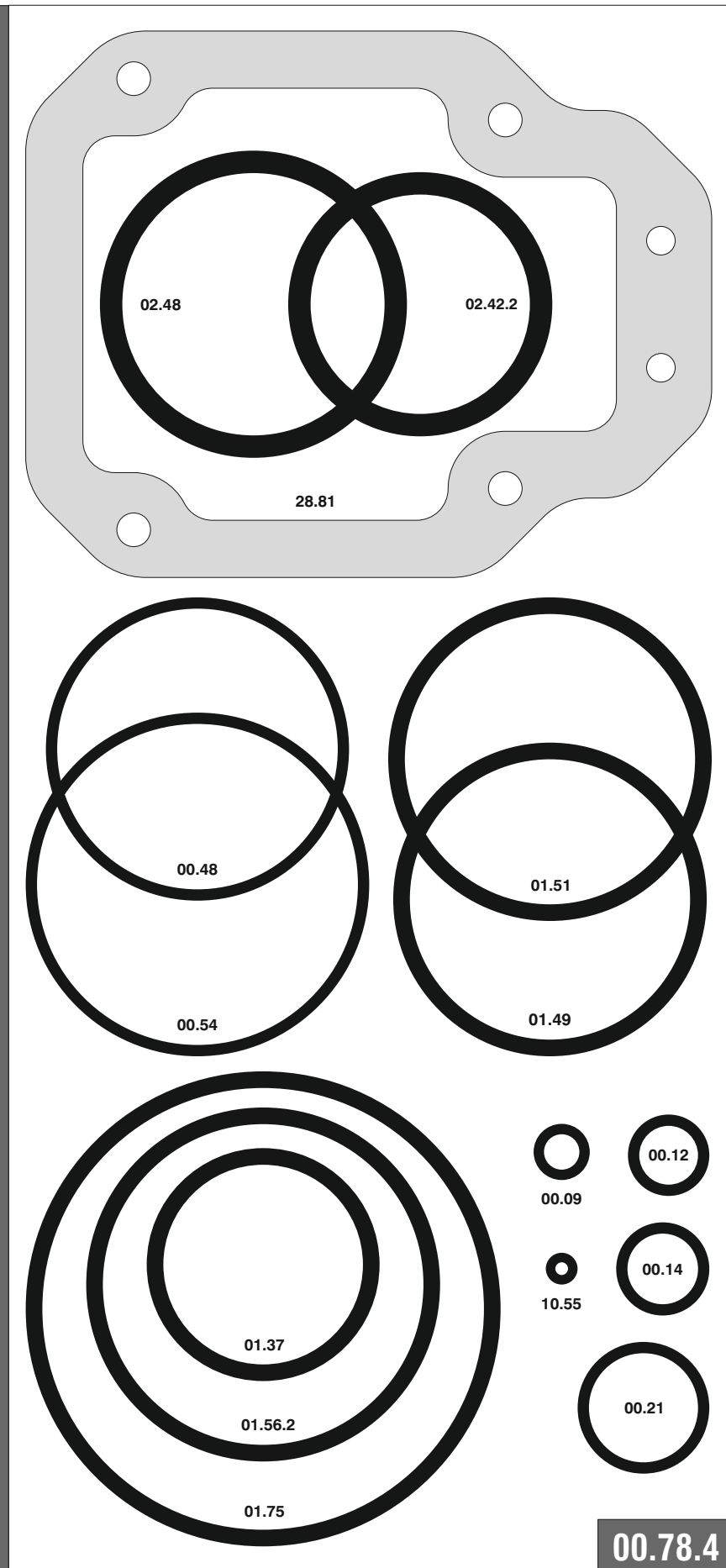

Indice di modifica
Upgrade number

4

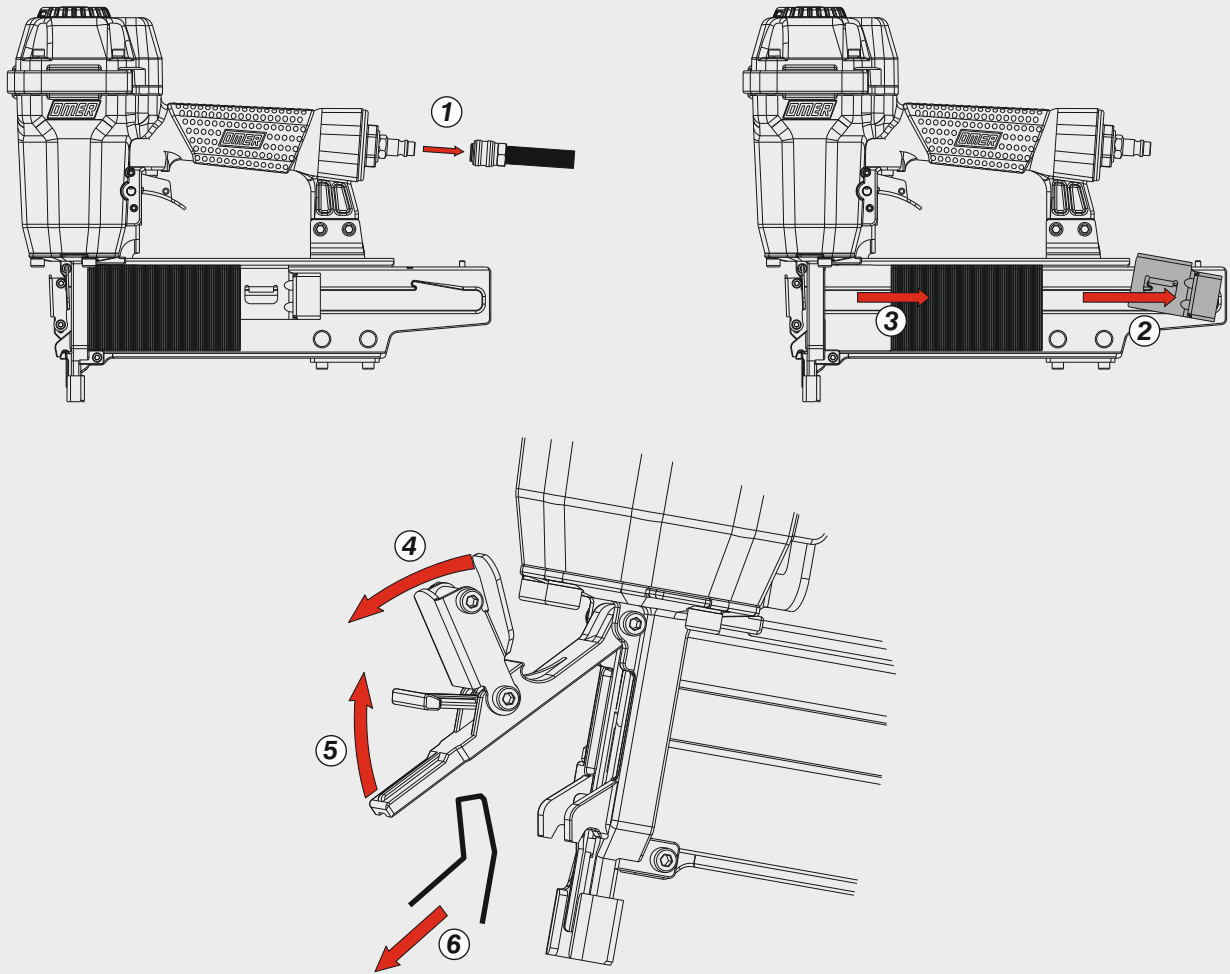

Accessori a richiesta - On request devices

Regolatore di profondità
Depth adjustment

Cod. 75.82.2

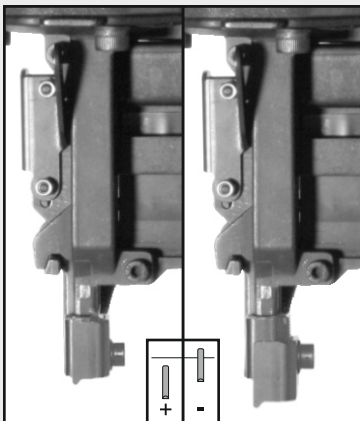

Azionamento sequenziale singolo
Single sequential actuation

Cod. 81.83.1K

