

Manuale d'uso, manutenzione e parti di ricambio	Parte 2
Manual for use, maintenance and spare parts	Part 2
Bedienungs- und Wartungshandbuch sowie Ersatzteilliste	Teil 2
Mode d'emploi, de maintenance et pièces de rechange	Partie 2
Manual de uso, mantenimiento y recambios	Part 2
Εγχειρίδιο χρήσης, συντήρησης και ανταλλακτικών	Μέρος 2
Manual de uso, manutenção e peças sobresselentes	Parte 2
Handleiding voor gebruik, onderhoud en wisselstukken	Deel 2
Kullanım, bakım ve yedek parça kılavuzu	Kısım 2

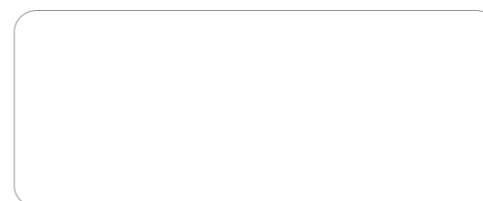

M2.50-3

cod. 1858200-3

Dati tecnici Technical data Technische Daten	Caractéristiques techniques Datos técnicos Τεχνικά χαρακτηριστικά	Dados técnicos Technische gegevens Teknik veriler
---	--	--

Misure impiegabili mm Lengths mm Verwendbare Nagellänge mm	Dimensions utiles mm Medidas de longitud mm Μήκος Αναλωσίμου - mm	Medidas utilizáveis mm Toepasbare afmetingen mm Boy mm	20 ÷ 50
Capacità caricatore n° punti Magazine capacity Magazinkapazität Nägel	Capacité chargeur n° de points Capacidad cargador n° puntos Δωνατοτητα γεμιστερα	Capacidade carregador n° pontos Capaciteit magazijn in aantal spijkers Dergi kapasitesi	145
Pressione d'esercizio Operating pressure Betriebsdruck	Pression d'exercice Presión de servicio Πίεση λειτουργίας	Pressão de serviço Werkdruk Çalışma basıncı	5 ÷ 7,5 bar 70 ÷ 105 psi
Consumo aria litri/colpo Air consumption litres/stroke Luftverbrauch Liter/Schuss	Consumption d'air litres/coup Consumo aire litros/golpe Κατανάλωση αέρα - λίτρα/βολή	Consumo ar litros/disparo Luchtverbruik liter/slag Litre/vuruş hava tüketimi	1,22
Peso kg Weight kg Gewicht kg	Poids kg Peso kg Βάρος - kg	Peso kg Gewicht in kg Ağırlık kg	2,2
Dimensioni mm Dimensions mm Abmessungen mm	Dimensions mm Dimensiones mm Διαστάσεις mm	Dimensões mm Afmetingen mm Boyutlar mm	352x91x256 (LxWxH)
UNI EN 12549 :2009	UNI EN ISO 3746 :2011	UNI EN ISO 4871 :2009	
Potenza sonora emessa Sound power emitted Emittierte Schalleistung	Puissance sonore émise Potencia sonora emitida Εκπεμπόμενη ηχητική ισχύς	Potência sonora emitida Geëmitteerd geluidsvermogen Çıkan ses gücü (ses desibeli)	99 dB(A) (K = 4 dB)

Tipo di punto
Type of fastener
Befestigungsmittel
Type de rivet
Tipo de punto
Τύπος αναλωσίμου
Tipo de agrafó
Type nietjes
Zimba ve çivi tipleri

M2

1,40x1,60

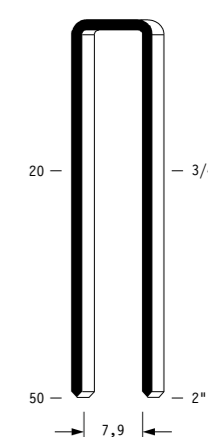

Crown: .421" (7/16")

Gauge: 16

1858200-3_M250-3_5_rev20_11/01/2021 IV

**DO NOT
HANDHELD
THIS TOOL**



Parti di ricambio - Spare parts - Ersatzteile - Pièces de rechange - Recambios
Ανταλλακτικά - Partes sobresselentes - Wisselstukken - Yedek parçalar

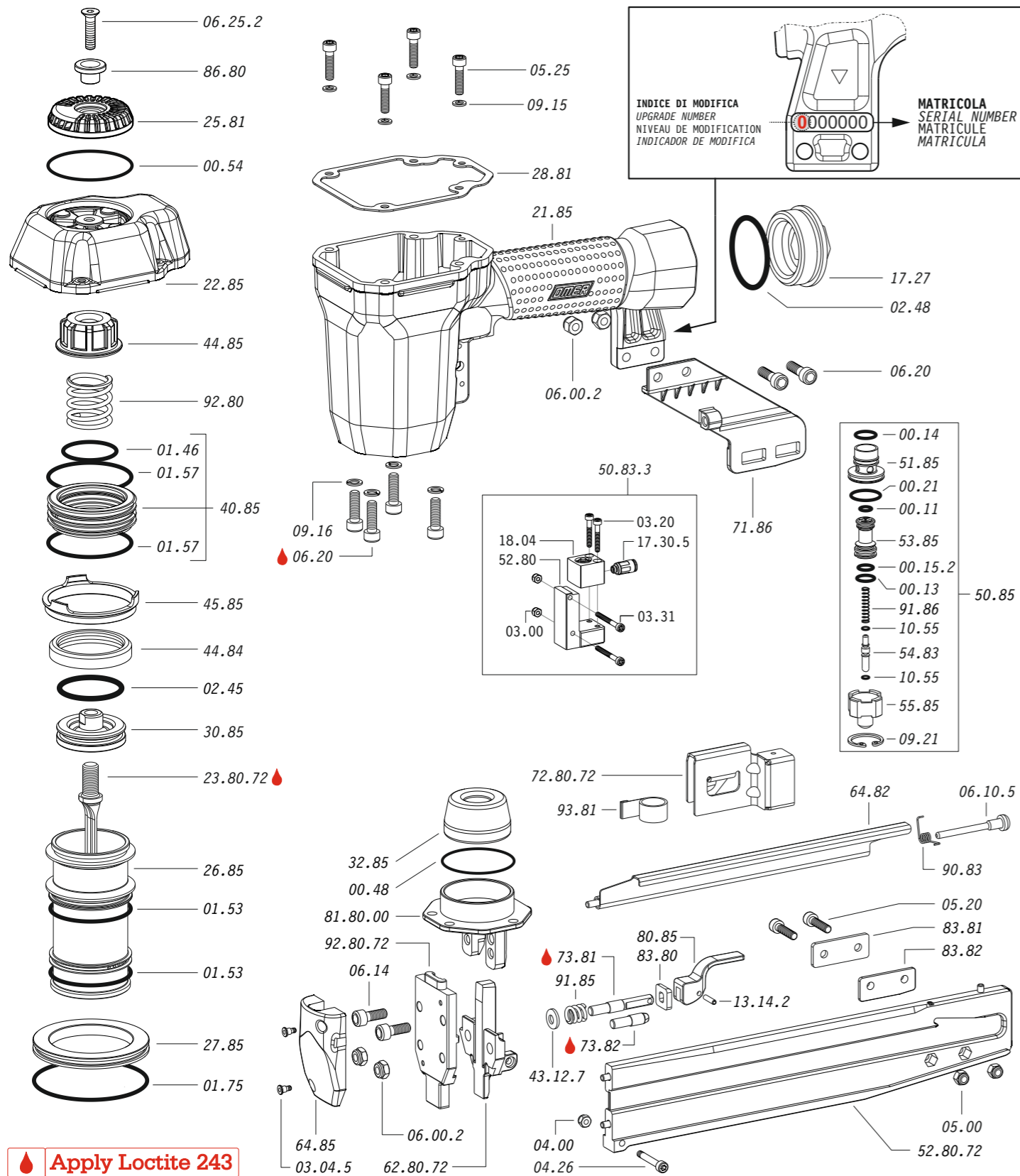

Dotazioni - Equipment - Ausstattung - Outillage - Dotaciones - Εξοπλισμός
Dotações - Uitrusting - Donanımlar

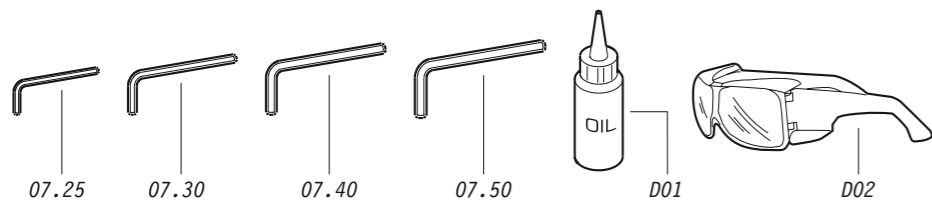

M2.50-3

cod. 1858200-3

Schema di collegamento - Connecting diagram

Collegamento per valvola 3/2 NC
Connection for valve 3/2 NC

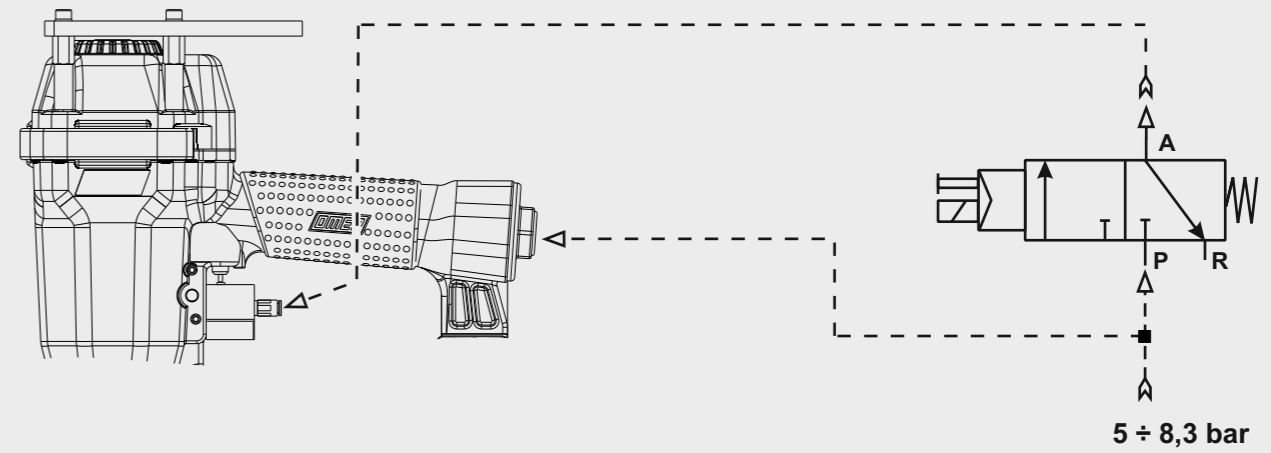

Note - Notes - Hinweise - Remarques - Notas - Σημειώσεις - Observações - Opmerkingen - Notlar

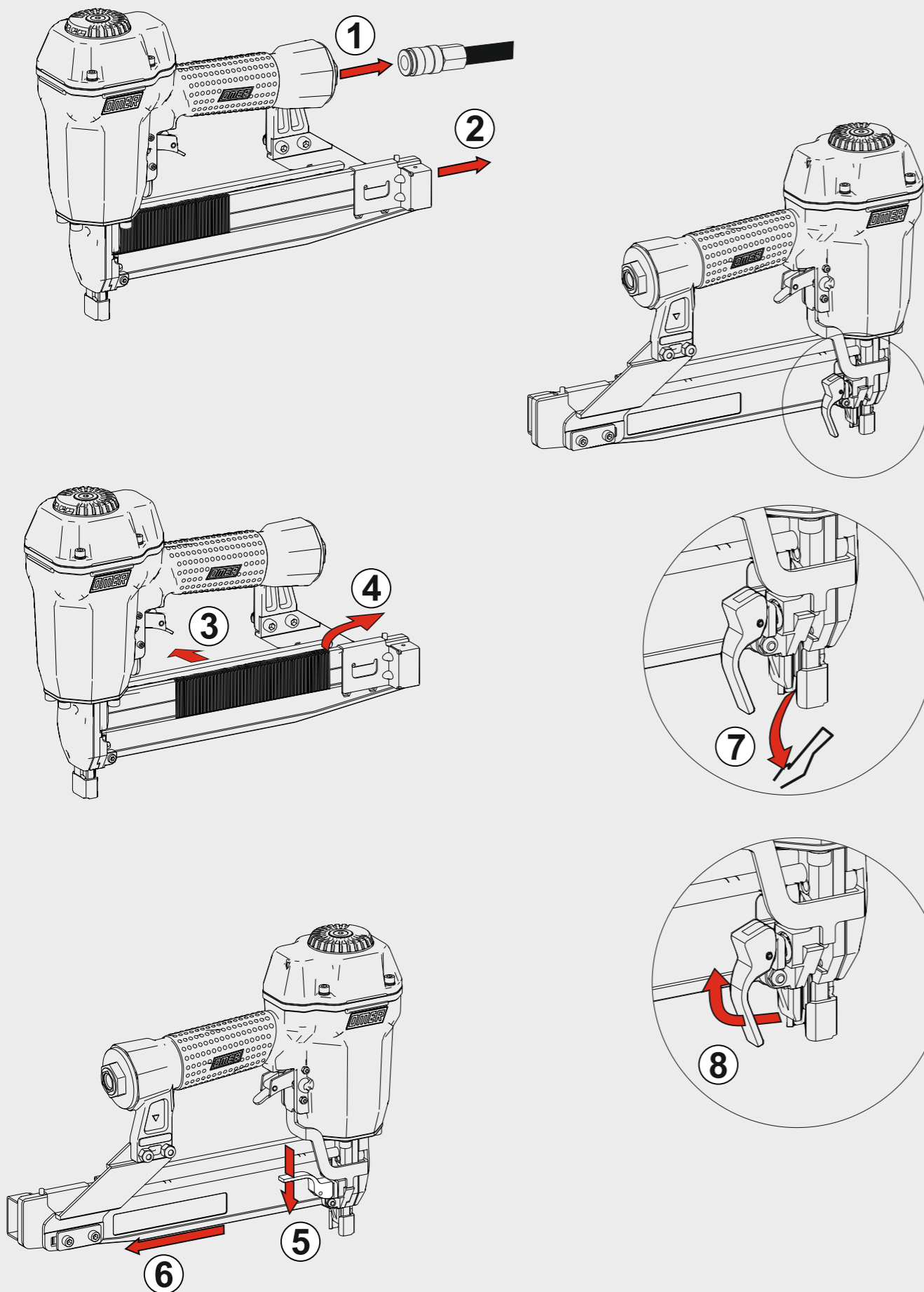

Cod.	Descrizione	Description
00.11	O-Ring	O-Ring
00.13	O-Ring	O-Ring
00.14	O-Ring	O-Ring
00.15.2	O-Ring	O-Ring
00.21	O-Ring	O-Ring
00.48	O-Ring	O-Ring
00.54	O-Ring	O-Ring
01.46	O-Ring	O-Ring
01.53	O-Ring	O-Ring
01.57	O-Ring	O-Ring
01.75	O-Ring	O-Ring
02.45	O-Ring	O-Ring
02.48	O-Ring	O-Ring
03.00	Dado	Nut
03.04.5	Vite	Screw
03.20	Vite	Screw
03.31	Vite	Screw
04.00	Dado	Nut
04.26	Vite	Screw
05.00	Dado	Nut
05.20	Vite	Screw
05.25	Vite	Screw
06.00.2	Dado	Nut
06.10.5	Vite	Screw
06.14	Vite	Screw
06.20	Vite	Screw
06.25.2	Vite	Screw
07.25	Chiave esagonale	Hex. bar wrench
07.30	Chiave esagonale	Hex. bar wrench
07.40	Chiave esagonale	Hex. bar wrench
07.50	Chiave esagonale	Hex. bar wrench
09.15	Rondella	Washer
09.16	Rondella	Washer
09.21	Anello elastico	Elastic ring
10.55	O-Ring	O-Ring
13.14.2	Spina	Pin
17.27	Tappo	Inlet cap
17.30.5	Raccordo	Connection
18.04	Pistoncino	Piston
21.85	Corpo	Body
22.85	Testa	Head
25.81	Deflettore	Deflector
26.85	Cilindro	Cylinder
27.85	Anello cilindro	Cylinder ring
28.81	Guarnizione testa	Head gasket
30.85	Pistone	Piston
32.85	Ammortizzatore	Bumper
40.85	Valvola completa	Valve ass'y
43.12.7	Rondella	Washer
44.84	Guarnizione cilindro	Cylinder gasket
44.85	Ammortizzatore	Bumper
45.85	Distanziale	Spacer
50.85	Pulsante completo	Trigger valve ass'y
50.83.3	Comando a distanza	Remote control
51.85	Boccola pulsante	Trigger valve housing
52.80	Supporto	Support
53.85	Pistone servovalvola	Valve piston
54.83	Pulsante	Trigger valve
55.85	Raccordo pulsante	Bush
64.82	Carter	Hold down
64.85	Carter sicura	Safety Guard
71.86	Reggicaricatore	Support
73.81	Perno	Pin
73.82	Perno	Pin
80.85	Leva	Lever
83.80	Rondella	Washer
83.81	Piastrina	Plate
83.82	Piastrina	Plate
86.80	Boccola	Bush
90.83	Molla	Spring
91.85	Molla	Spring
91.86	Molla	Spring
92.80	Molla	Spring
93.81	Molla	Spring
23.80.72	Battente	Driver
52.80.72	Caricatore	Magazine
62.80.72	Nasello	Nose
72.80.72	Spingipunto	Pusher
81.80.00	Flangia	Flange
92.80.72	Testina	Nose plate
D01	Bocchetta olio	Oiler
D02	Occhiali protettivi	Protective goggles

Guarnizioni - O-Rings - Dichtungen - Joints toriques - Juntas - Δακτύλιος στεγανοποίησης - Vedantes - O-ringen - Contalar

