

Caratteristiche - Features - Merkmale - Caractéristiques - Características - Χαρακτηριστικά - Características - Kenmerken - Özellikler



Manuale d'uso, manutenzione e parti di ricambio
Manual for use, maintenance and spare parts
Bedienungs- und Wartungshandbuch sowie Ersatzteilleiste
Mode d'emploi, de maintenance et pièces de rechange
Manual de uso, mantenimiento y recambios
Εγχειρίδιο χρήσης, συντήρησης και ανταλλακτικών
Manual de uso, manutenção e peças sobresselentes
Handleiding voor gebruik, onderhoud en wisselstukken
Kullanım, bakım ve yedek parça kılavuzu

Parte 2
Part 2
Teil 2
Partie 2
Part 2
Μέρος 2
Parte 2
Deel 2
Kısım 2



1016.50

cod. 1858600



Warning: Please read the instructions and warnings for this tool carefully before use. Failure to do so could lead to serious injury.

Dati tecnici Technical data Technische Daten	Caractéristiques techniques Datos técnicos Τεχνικά χαρακτηριστικά	Dados técnicos Technische gegevens Teknik veriler	
Misure impiegabili mm Lengths mm Verwendbare Nagellänge mm	Dimensions utiles mm Medidas de longitud mm Μήκος Αναλωσίμου - mm	Medidas utilizáveis mm Toepasbare afmetingen mm Boy mm	20 ÷ 50
Capacità caricatore n° punti Magazine capacity Magazinkapazität Nägel	Capacité chargeur n° de points Capacidad cargador n° puntos Δωσατοτητα γεμιστερα	Capacidade carregador n° pontos Capaciteit magazijn in aantal spijkers Dergi kapasitesi	145
Pressione d'esercizio Operating pressure Betriebsdruck	Pression d'exercice Presión de servicio Πίεση λειτουργίας	Pressão de serviço Werkdruk Çalışma basıncı	5 ÷ 7,5 bar 70 ÷ 105 psi
Consumo aria litri/colpo Air consumption litres/stroke Luftverbrauch Liter/Schuss	Consommation d'air litres/coup Consumo aire litros/golpe Κατανάλωση αέρα - λίτρα/βολή	Consumo ar litros/disparo Luchtverbruik liter/slag Litre/vuruş hava tüketimi	1,22
Peso kg Weight kg Gewicht kg	Poids kg Peso kg Βάρος - kg	Peso kg Gewicht in kg Ağırlık kg	2,24
Dimensioni mm Dimensions mm Abmessungen mm	Dimensions mm Dimensiones mm Διαστάσεις mm	Dimensões mm Afmetingen mm Boyutlar mm	352x91x263 (LxWxH)
UNI EN 12549 :2009 UNI EN ISO 4871 :2009	Pressione sonora in pos. operatore Sound pressure in operator's position Schalldruck am Arbeitsplatz	Pressão sonora na posição Operador Geluidsdruk op de werkplaats Operatör pozisyonunda ses basıncı	92 dB(A) (K= 4 dB)
UNI EN 12549 :2009 UNI EN ISO 3746 :2011 UNI EN ISO 4871 :2009	Potenza sonora emessa Sound power emitted Emittierte Schalleistung	Potência sonora emitida Geëmitteerd geluidsvermogen Çıkan ses gücü (ses desibel)	99 dB(A) (K= 4 dB)
UNI CEN ISO/TS 8662-11 :2006 UNI EN ISO 5349-2 :2004 UNI EN 12096 :1999	Emissione vibratoria sull'impugnatura Vibratory emissions on handle Vibrationsemission am Griff	Êmissão vibratória na empunhadura Trillingsemissie op de handgreep Tutamak üzerinde vibrasyon emisyonları	4,16 m/s² (K= 2 m/s ²)

Tipo di punto
Type of fastener
Befestigungsmittel
Type de rivet
Tipo de punto
Τύπος αναλωσίμου
Tipo de agrafó
Type nietjes
Zimba ve çivi tipleri

1016

1,40x1,60

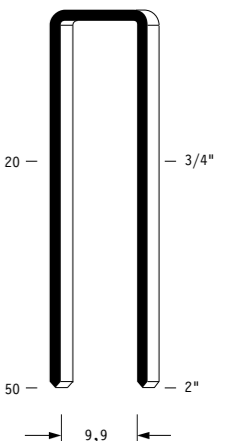

Crown: .500 (1/2")
Gauge: 16

Parti di ricambio - Spare parts - Ersatzteile - Pièces de rechange - Recambios
Ανταλλακτικά - Partes sobresselentes - Wisselstukken - Yedek parçalar

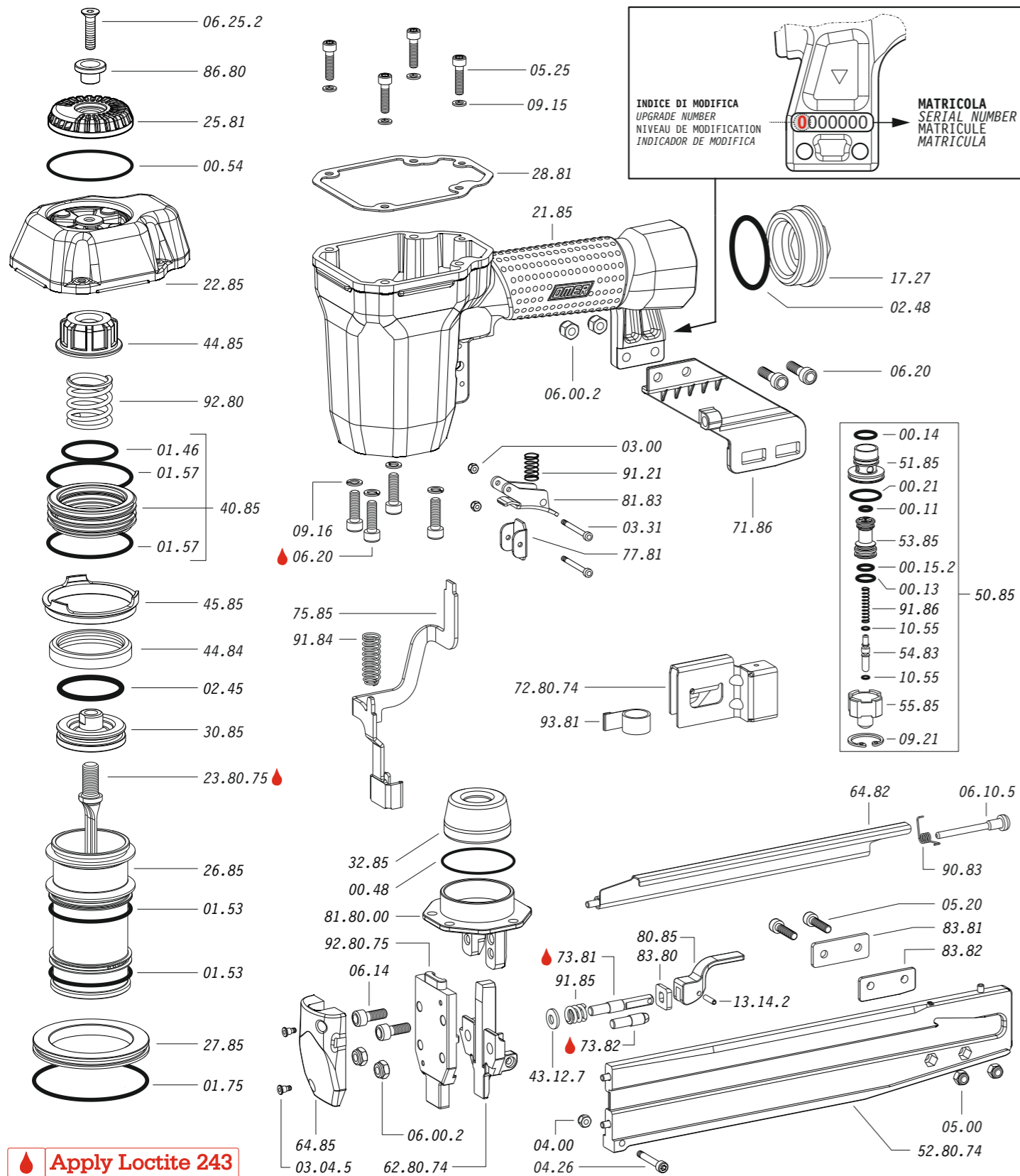

Dotazioni - Equipment - Ausstattung - Outillage - Dotaciones - Εξοπλισμός
Dotações - Uitrusting - Donanımlar

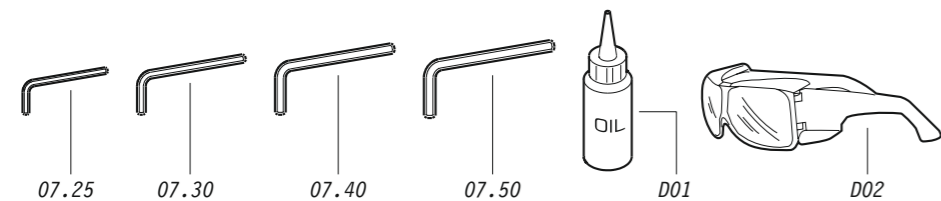

1016.50

cod. 1858600

Dispositivi a richiesta - On request devices

Regolazione di profondità
Depth adjustment

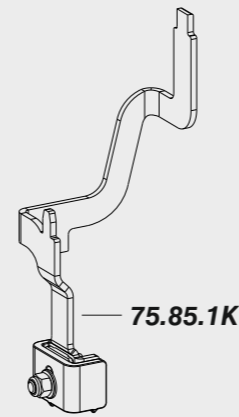

Sicura per superfici fragili
Fragile surfaces safety

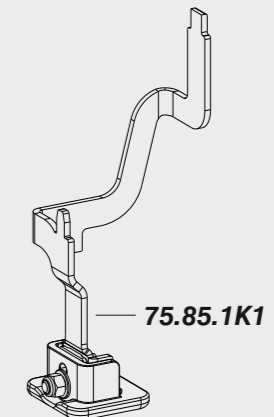

Note - Notes - Hinweise - Remarques - Notas - Σημειώσεις - Observações - Opmerkingen - Notlar

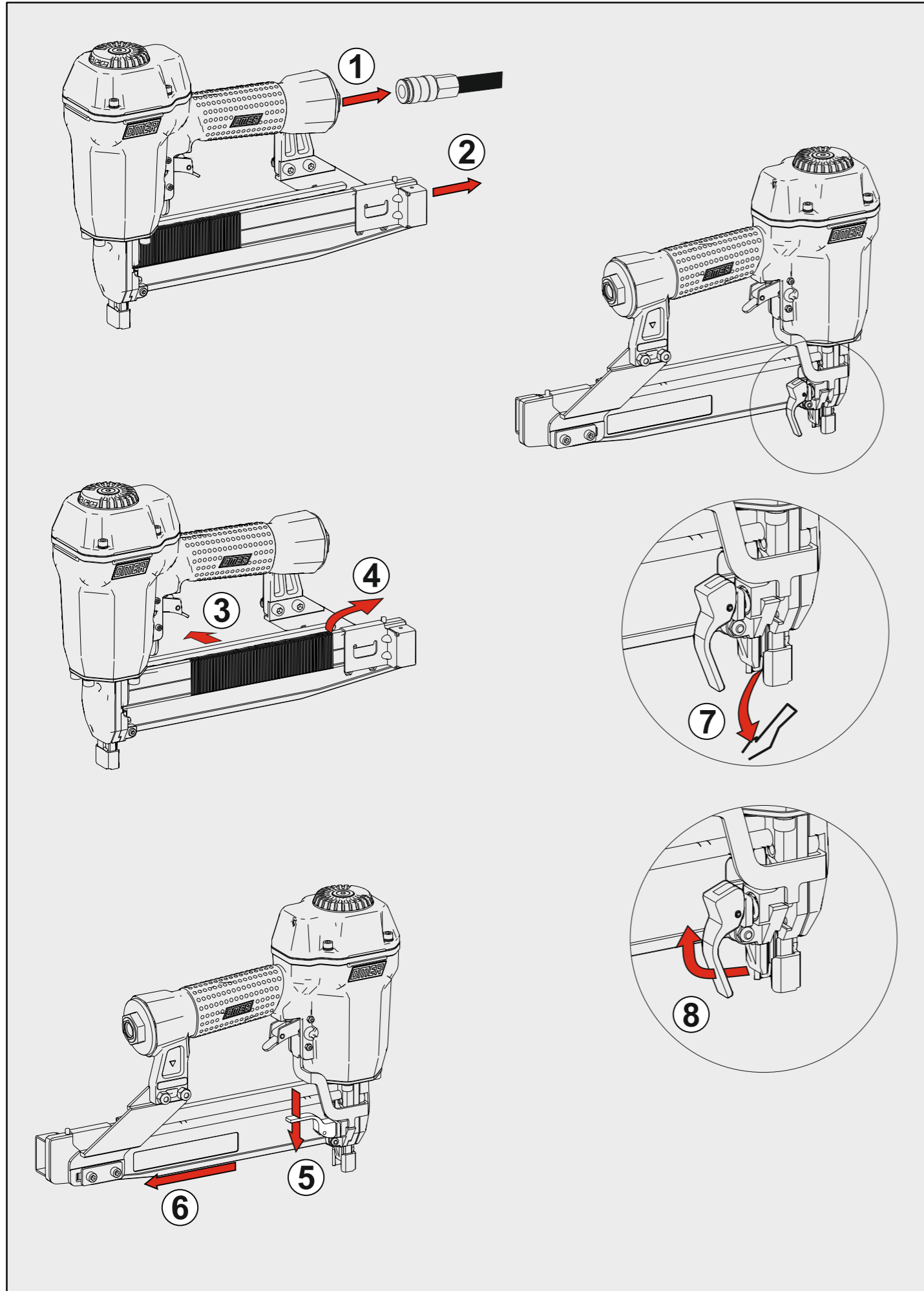

Cod.	Descrizione	Description
00.11	O-Ring	O-Ring
00.13	O-Ring	O-Ring
00.14	O-Ring	O-Ring
00.15.2	O-Ring	O-Ring
00.21	O-Ring	O-Ring
00.48	O-Ring	O-Ring
00.54	O-Ring	O-Ring
01.46	O-Ring	O-Ring
01.53	O-Ring	O-Ring
01.57	O-Ring	O-Ring
01.75	O-Ring	O-Ring
02.45	O-Ring	O-Ring
02.48	O-Ring	O-Ring
03.00	Dado	Nut
03.04.5	Vite	Screw
03.31	Vite	Screw
04.00	Dado	Nut
04.26	Vite	Screw
05.00	Dado	Nut
05.20	Vite	Screw
05.25	Vite	Screw
06.00.2	Dado	Nut
06.10.5	Vite	Screw
06.14	Vite	Screw
06.20	Vite	Screw
06.25.2	Vite	Screw
07.25	Chiave esagonale	Hex. bar wrench
07.30	Chiave esagonale	Hex. bar wrench
07.40	Chiave esagonale	Hex. bar wrench
07.50	Chiave esagonale	Hex. bar wrench
09.15	Rondella	Washer
09.16	Rondella	Washer
09.21	Anello elastico	Elastic ring
10.55	O-Ring	O-Ring
13.14.2	Spina	Pin
17.27	Tappo	Inlet cap
21.85	Corpo	Body
22.85	Testa	Head
25.81	Deflettore	Deflector
26.85	Cilindro	Cylinder
27.85	Anello cilindro	Cylinder ring
28.81	Guarnizione testa	Head gasket
30.85	Pistone	Piston
32.85	Ammortizzatore	Bumper
40.85	Valvola completa	Valve ass'y
43.12.7	Rondella	Washer
44.84	Guarnizione cilindro	Cylinder gasket
44.85	Ammortizzatore	Bumper
45.85	Distanziale	Spacer
50.85	Pulsante completo	Trigger valve ass'y
51.85	Boccola pulsante	Trigger valve housing
53.85	Pistone servovalvola	Valve piston
54.83	Pulsante	Trigger valve
55.85	Raccordo pulsante	Bush
64.82	Carter	Hold down
64.85	Carter sicura	Safety Guard
71.86	Reggicaricatore	Support
73.81	Perno	Pin
73.82	Perno	Pin
75.85	Sicura	Safety
77.81	Guida sicura	Safety guide
80.85	Leva	Lever
81.83	Grilletto comando	Trigger
83.80	Rondella	Washer
83.81	Piastrina	Plate
83.82	Piastrina	Plate
86.80	Boccola	Bush
90.83	Molla	Spring
91.21	Molla	Spring
91.84	Molla	Spring
91.85	Molla	Spring
91.86	Molla	Spring
92.80	Molla	Spring
93.81	Molla	Spring
23.80.75	Battente	Driver
52.80.74	Caricatore	Magazine
62.80.74	Nasello	Nose
72.80.74	Spingipunto	Pusher
81.80.00	Flangia	Flange
92.80.75	Testina	Nose plate
D01	Bocchetta olio	Oiler
D02	Occhiali protettivi	Protective goggles

Guarnizioni - O-Rings - Dichtungen - Joints toriques - Junta - Δακτύλιος στεγανοποίησης - Vedantes - O-ringen - Contalar

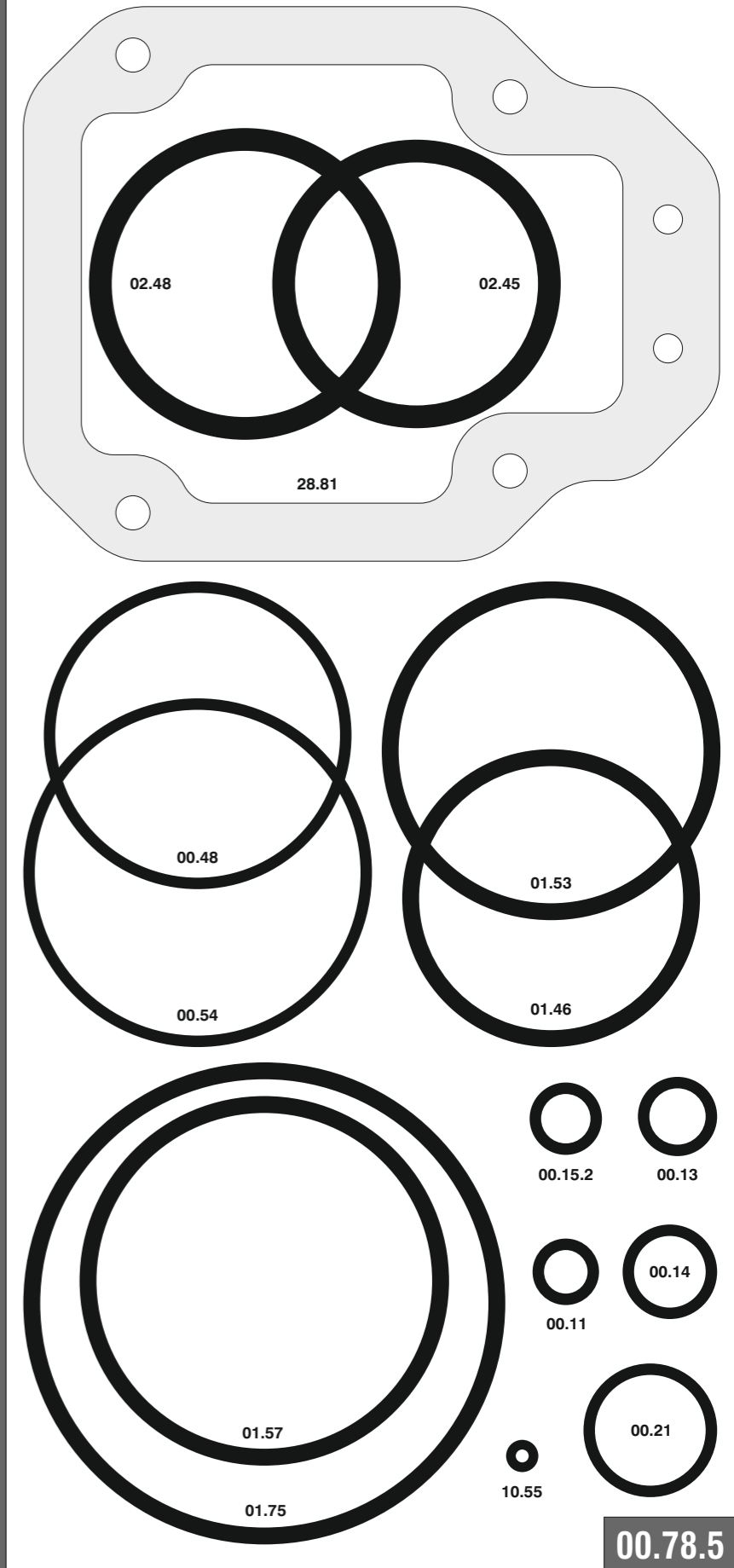

Azionamento a contatto
Contact actuation

81.83

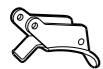

Di serie / Standard

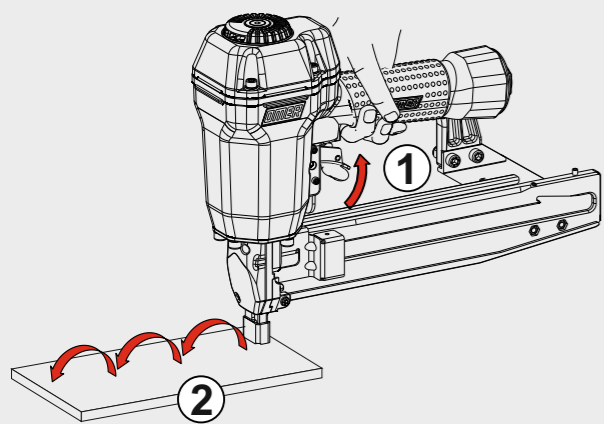

Oppure - Or

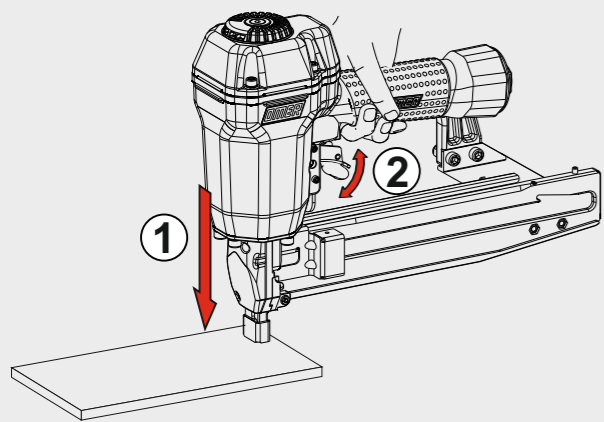

Azionamento sequenziale singolo
Single sequential actuation

81.83.1

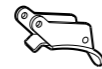

A richiesta / On request

