



<b>Manuale d'uso, manutenzione e parti di ricambio</b>	<b>Parte 2</b>
<b>Use, maintenance and spare parts manual</b>	<b>Part 2</b>
<b>Gebrauchsanweisung, Instandhaltungsrichtlinien und Ersatzteile</b>	<b>Teil 2</b>
<b>Manuel d'utilisation, entretien et pièces de rechange</b>	<b>Partie 2</b>
<b>Manual de uso, mantenimiento y repuestos</b>	<b>Part 2</b>
Εγχειρίδιο χρήσης, συντηρησης και ανταλλακτικών	2° Μέρος
<b>Manual de utilização, manutenção e partes sobresselentes</b>	<b>Parte 2</b>
<b>Handleiding voor gebruik, onderhoud en reservedelslste</b>	<b>Deel 2</b>
<b>Brugsanvisning, vedligeholdelse og reservedelslste</b>	<b>Del 2</b>

# PR.30

cod. 1140230-632

1140230-632\_PR30\_4 070617 IV

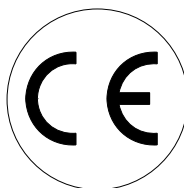

<b>Dati tecnici</b> Technical data Technische daten	<b>Données techniques</b> Datos tècnicos Τεχνικά χαρακτηριστικά	<b>Dados tècnicos</b> Technische gegevens Tehniske data
<b>Misure impiegabili mm</b> Usable lengths mm Gebrauchliche Längen mm	Mesures utilisable mm Medidas que se pueden emplear mm Διαστάσεις σε μμ	Medidas que se podem utilizar mm Te gebruiken engtes in mm Brugbare længder i mm
<b>Capacità caricatore n° punti</b> Magazine capacity No. of fasteners Magazinkapazität Nägel	Capacité chargeur n° de points Capacidad cargador n° puntos Δυνατότητα γεμιστέρα, σπινδότερες	Capacidade carregador n° pontos Capaciteit magazijn in aantal spijkers Kapasitet af magasin antal klemme
<b>Pressione d'esercizio</b> Working pressure Betriebsdruck	Pression de fonctionnement Presión de trabajo Πίεση λειτουργίας ατμ.	Pressao de trabalho Werkdruk Arbejds tryk bar
<b>Consumo aria litri/colpo</b> Air consumption litres/shot Luftverbrauch Liter/Schlag	Consommation air litre/coup Consumo aire-litros/golpe Κατανάλωση αερα λξτπημα	Consumo ar litro/golpe Luchtverbruik liter/schot Luftforbrug liter/skud
<b>Peso kg</b> Weight kg Gewicht kg	Poids kg Peso kg Βαρος κγ	Peso kg Gewicht in kg Vaegt kg
<b>Dimensioni (AxBxH) mm</b> Dimensions mm Größe mm	Dimension mm Dimensiones mm Δυνατότητα γεμιστέρα, σπινδότερες	Dimencoes mm Afmetingen in mm Dimensioner mm
<b>EN 12549 :1999 ISO 11201 :1995</b>		
<b>Pressione sonora in pos. operatore</b> Sound pressure at the workstation Lärmintensität am Arbeitsplatz	Pression acoustique près de l'opérateur Presión sonora en posición encargado Ακουστική πίεση στη θέση χειριστού	Intensidade sonora perto do operador Geluidssterkte op de werkplek Lydstyrke på operatorposten
<b>EN 12549 :1999 ISO 3744 :1994</b>		
<b>Potenza sonora emessa</b> Emitted sound power Ausgestrahlte Lärmintensität	Puissance acoustique émise Potencia sonora emitida Ακουστική ισχυ	Potência sonora emitida Uitgestraalde geluidssterkte Udsendt lydstryrke
<b>EN 28662 :1992 ISO 5349 :1986 ISO 8662 -11</b>		
<b>Valore medio ponderato di vibrazione sull'impugnatura max.33 colpi</b> Weighted mean value of vibration on the grip max.33 shots Mitteler Vibrationswert, am Griff gemessen max.33 Schläge	Valeur moyenne pondérée de vibration mesurée sur la poignée max.33 coups Valor medio ponderado de vibracion medida en la empuñadura max.33 golp Μεσοσ ορος μετρησις κραδασιμον στη χειρολαβη μαξ.33 ξτπημα	Valor medio ponderado de vibracao medida no punho max.33 golpes Gewogen gemiddelde vibratiewaarde max.33 schot Middelvaerdi af vibrationer pa handtaget max.33 skud

**Tipo di punto**  
Type of fastener  
Befestigungselement  
Type d'agrafe  
Tipo de punto  
Τυπος κορφτου  
Tipo de ponto  
Type nietjes  
Tilspændingstype

**Pins 6**

Ø 0,64

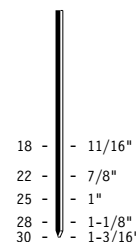

Wire dia: .025"  
Gauge: 23

Parti di ricambio - Spare parts - Ersatzteile - Pièces de rechange - Piezas de repuesto  
 Ανταλλακτικά - Partes sobresselentes - Tabel te raadplegen - Reservedele

Cod.	Descrizione	Description
00.06	O-Ring	O-Ring
00.12	O-Ring	O-Ring
00.13	O-Ring	O-Ring
00.14	O-Ring	O-Ring
00.26	O-Ring	O-Ring
00.27	O-Ring	O-Ring
00.35	O-Ring	O-Ring
01.21.1	Guarnizione	Gasket
01.29	O-Ring	O-Ring
01.33	O-Ring	O-Ring
03.06.3	Vite	Screw
04.08.2	Vite	Screw
04.10	Vite	Screw
04.12	Vite	Screw
04.14	Vite	Screw
04.18	Vite	Screw
04.22	Vite	Screw
04.35	Vite	Screw
05.08.1	Vite	Screw
07.03	Sfera	Ball
07.05	Sfera	Ball
07.25	Chiave esagonale	Hex. bar wrench
07.30	Chiave esagonale	Hex. bar wrench
09.02	Rondella	Washer
12.16.1	Spina	Pin
20.01	Corpo	Body
22.07	Testa	Head
24.00	Silenziatore	Silencer
25.04	Deflettore	Exhaust deflector
26.07	Cilindro	Cylinder
28.00	Guarnizione	Gasket
32.05	Ammortizzatore	Bumper
39.00	Guarnizione scarico	Exhaust gasket
40.04	Valvola completa	Valve ass'y
45.04	Anello valvola	Ring
54.03	Pulsante	Trigger valve
55.06	Raccordo	Bush
59.02.1	Regolatore	Adjusting
61.02	Guida dx	Dx guide
68.04.1	Distanziale	Space
70.01	Puntale	Contact tip
72.07	Reggicaricatore	Slider-stop
76.04	Perno	Pin
76.14	Perno	Pin
80.07	Grilletto chiusura	Trigger lock
81.09	Grilletto comando	Trigger
81.15	Contro grilletto	Trigger
81.35	Leva regolazione	Adjusting lever
86.57	Vite	Screw
90.11	Molla	Spring
90.10	Molla	Spring
91.02	Molla	Spring
91.03X	Molla	Spring
92.01X	Molla	Spring
93.02	Molla	Spring
94.02.1	Tirante	Connecting rod
22.02.05	Battente	Driver
53.01.08	Caricatore	Magazine
63.00.08	Carrrello	Slider
73.01.08	Spingipunto	Pusher
83.00.05	Controtestina	Nose
94.00.08	Testina	Nose plate
D01	Bocchetta olio	Oiler

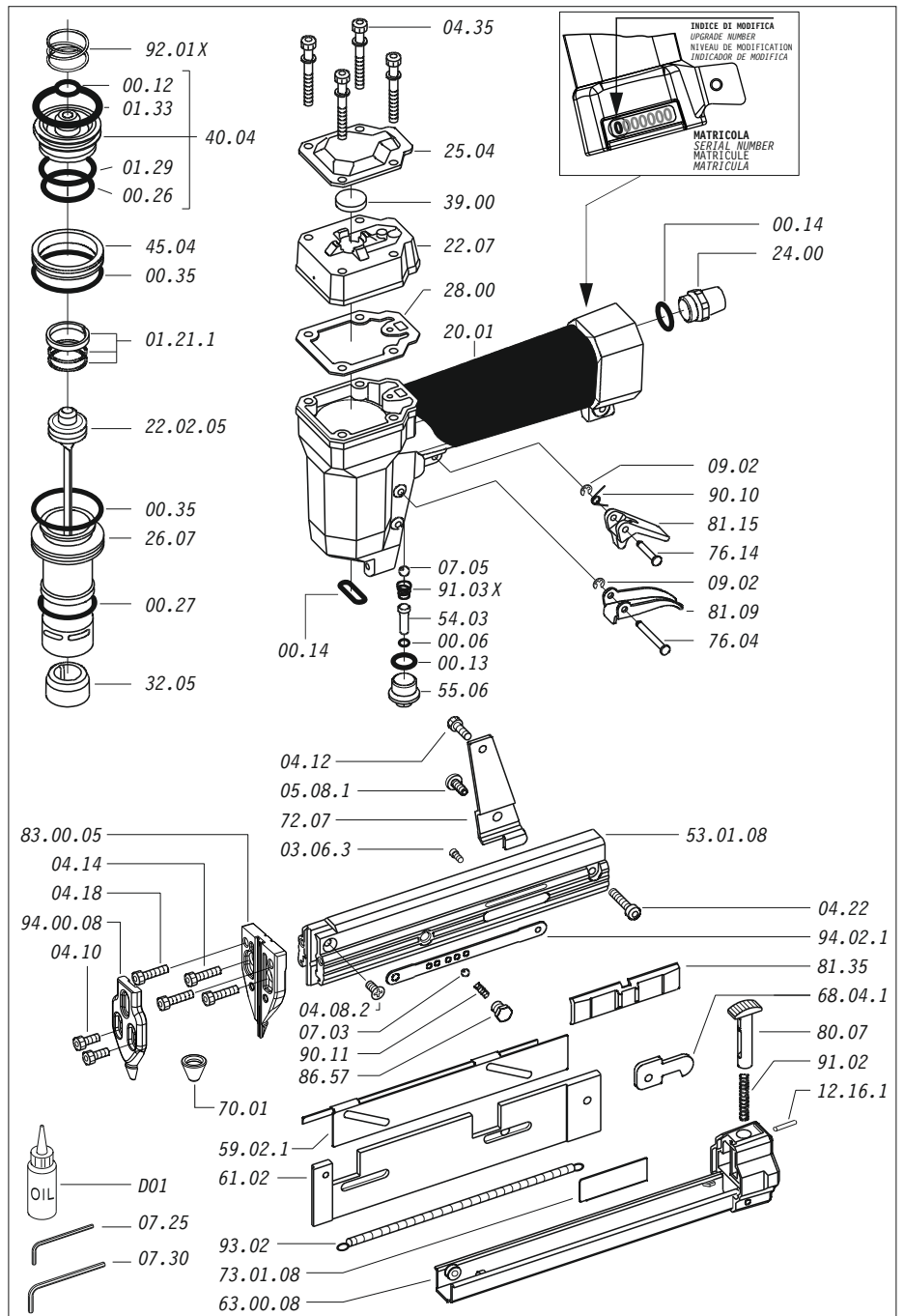

Guarnizioni - O-Rings - Dichtungen - Joints - Empaquetadura de anillo - Λαστιχακια - Kit de o-rings - O-ringen - Pakninger

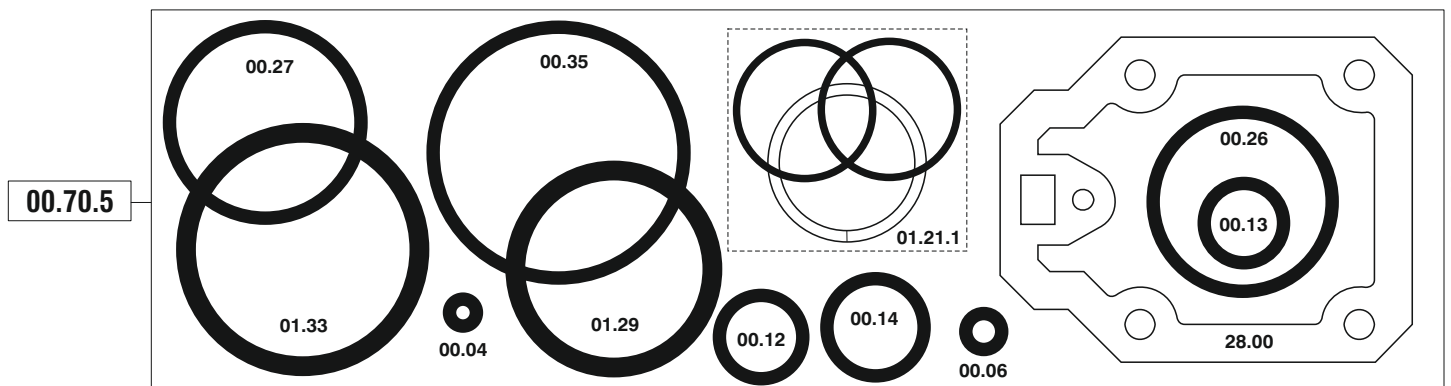

PR.30

cod. 1140230-632

Indice di modifica  
Upgrade number

4