

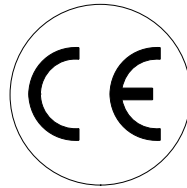

# MG.30 ACD1

cod. 1140810ACD1

1140810ACD1\_MG30ACD1\_4 220316 IV



### Dati tecnici

Technical data  
Technische daten

### Données techniques

Datos tècnics  
Τεχνικά χαρακτηριστικά

### Dados tècnicos

Technische gegevens  
Teknische data

<b>Misure impiegabili mm</b> Usable lengths mm Gebrauchliche Längen mm	Mesures utilisable mm Medidas que se pueden emplear mm Διαστάσεις σε μμ	Medidas que se podem utilizar mm Te gebruiken engtes in mm Brugbare lengder i mm	<b>12 ÷ 30 (Brads M) 30 (Pins 8)</b>
<b>Capacità caricatore n° punti</b> Magazine capacity No. of fasteners Magazinkapazität Nägel	Capacité chargeur n° de points Capacidad cargador n° puntos Δυνατότητα γεμιστέρα, σπινδότερες	Capacidade carregador n° pontos Capaciteit magazijn in aantal spijkers Kapacitet af magasin antal klemme	<b>150</b>
<b>Pressione d'esercizio</b> Working pressure Betriebsdruck	Pression de fonctionnement Presión de trabajo Πίεση λειτουργίας ατμ.	Pressao de trabalho Werkdruk Arbejds tryk bar	<b>4,5 ÷ 7 bar 65 ÷ 100 psi</b>
<b>Consumo aria litri/colpo</b> Air consumption litres/shot Luftverbrauch Liter/Schlag	Consommation air litre/coup Consumo aire-litros/golpe Κατανάλωση αερα λ/ξτύπημα	Consumo ar litro/golpe Luchtverbruik liter/schot Luftforbrug liter/skud	<b>0,15</b>
<b>Peso kg</b> Weight kg Gewicht kg	Poids kg Peso kg Βαρος κγ	Peso kg Gewicht in kg Vaegt kg	<b>1,02</b>
<b>Dimensioni (AxBxH) mm</b> Dimensions mm Größe mm	Dimension mm Dimensiones mm Δυνατότητα γεμιστέρα, σπινδότερες	Dimencoes mm Afmetingen in mm Dimensioner mm	<b>213x43x167</b>
<b>EN 12549 :1999 ISO 11201 :1995</b>			
<b>Pressione sonora in pos. operatore</b> Sound pressure at the workstation Lärmintensität am Arbeitsplatz	Pression acoustique près de l'opérateur Presión sonora en posición encargado Ακουστική πίεση στη θέση χειριστού	Intensidade sonora perto do operador Geluidssterkte op de werkplek Lydstyrke på operatorposten	<b>84,3 dB(A)</b>
<b>EN 12549 :1999 ISO 3744 :1994</b>			
<b>Potenza sonora emessa</b> Emitted sound power Ausgestrahlte Lärmintensität	Puissance acoustique émise Potencia sonora emitida Ακουστική ισχυ	Potência sonora emitida Uitgestraalde geluidssterkte Udsendt lydstryke	<b>93,7 dB(A)</b>
<b>EN 28662 :1992 ISO 5349 :1986 ISO 8662 -11</b>			
<b>Valore medio ponderato di vibrazione sull'impugnatura max.33 colpi</b> Weighted mean value of vibration on the grip max.33 shots Mittlerer Vibrationswert, am Griff gemessen max.33 Schläge	Valeur moyenne pondérée de vibration mesurée sur la poignée max.33 coups Valor medio ponderado de vibracion medida en la empuñadura max.33 golp Μέσος ορος μετρησης κραδασμων στη χειρολαβη μαξ.33 ξτύπημα	Valor medio ponderado de vibracao medida no punho max.33 golpes Gewogen gemiddelde vibratiewaarde max.33 schot Middelveardi af vibrationer pa handtaget max.33 skud	<b>&lt;2,5 m/s<sup>2</sup></b>

**Tipo di punto**  
Type of fastener  
Befestigungselement  
Type d'agrafe  
Tipo de punto  
Τύπος κορφίου  
Tipo de ponto  
Type nietjes  
Tilspændingstype

### Brads M

Ø 0,84



12 - -1/2"  
15 - -5/8"  
18 { } 11/16"  
21 { } 7/8"  
25 - -1"  
28 { } 1-1/8"  
30 { } 1-3/16"

Head width: .055"  
Wire dia: .033"  
Gauge: 21

### Pins 8

Ø 0,84



30 - -1-3/16"  
Wire dia: .033"  
Gauge: 21

Parti di ricambio - Spare parts - Ersatzteile - Pièces de rechange - Piezas de repuesto  
 Ανταλλακτικά - Partes sobresselentes - Tabel te raadplegen - Reservedele

Cod.	Descrizione	Description
00.04	O-Ring	O-Ring
00.06	O-Ring	O-Ring
00.12	O-Ring	O-Ring
00.13	O-Ring	O-Ring
00.14	O-Ring	O-Ring
00.26	O-Ring	O-Ring
00.27	O-Ring	O-Ring
00.35	O-Ring	O-Ring
01.21.1	Guarnizione	Gasket
01.29	O-Ring	O-Ring
01.33	O-Ring	O-Ring
03.00	Dado	Nut
03.30	Vite	Screw
03.60.2	Vite	Screw
04.00	Dado	Nut
04.05	Vite	Screw
04.08	Vite	Screw
04.08.2	Vite	Screw
04.10.2	Vite	Screw
04.12	Vite	Screw
04.16	Vite	Screw
04.35	Vite	Screw
07.30	Chiave esagonale	Hex. bar wrench
12.16.1	Spina	Pin
17.30.5	Attacco	Connection
20.01	Corpo	Body
22.07	Testa	Head
24.00	Silenziatore	Silencer
25.04	Deflettore	Exhaust deflector
26.07	Cilindro	Cylinder
28.00	Guarnizione	Gasket
32.05	Ammortizzatore	Bumper
39.00	Guarnizione scarico	Exhaust gasket
40.04	Valvola completa	Valve ass'y
45.04	Anello valvola	Ring
50.03	Pulsante completo	Trigger valve ass'y
50.06.1	Comando a distanza	Remote control trigger
52.02	Raccordo	Bush
54.04	Pulsante	Trigger valve
55.06.1	Raccordo	Bush
61.00	Guida dx	Dx guide
62.01	Banchina	Magazine body
64.03	Fondello	Cap
66.03	Rondella	Washer
72.04	Reggicaricatore	Support
80.07	Grilletto chiusura	Trigger lock
86.19	Carrucola	Pulley
91.02	Molla	Spring
91.08	Molla	Spring
92.01X	Molla	Spring
93.21	Molla	Spring
94.01	Molla	Spring
22.04.08	Battente	Driver
52.00.08	Caricatore	Magazine
72.00.08	Spingipunto	Pusher
93.04.08	Testina	Nose plate
D01	Bocchetta olio	Oiler

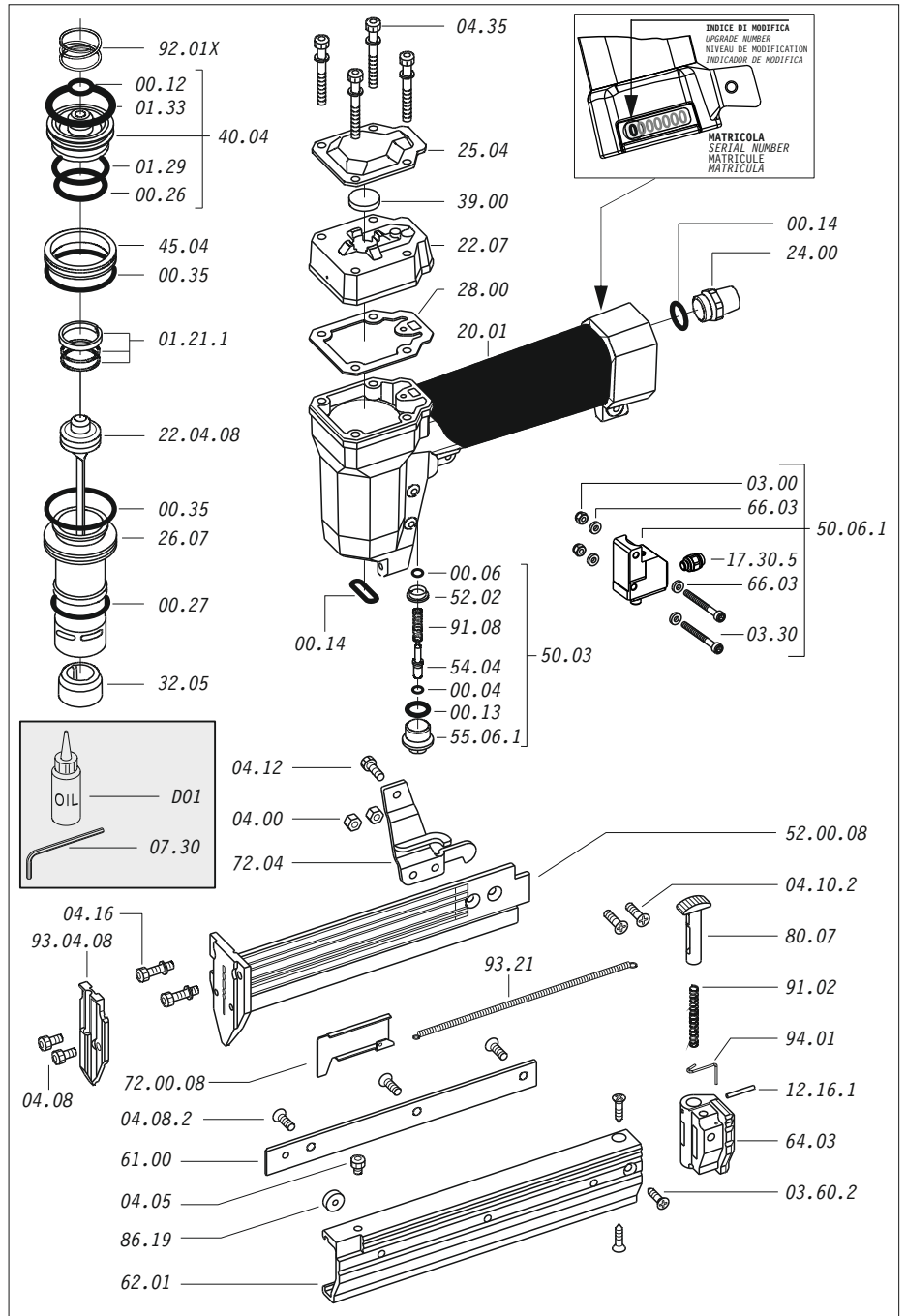

Guarnizioni - O-Rings - Dichtungen - Joints - Empaquetadura de anillo - Λαστιχάκια - Kit de o-rings - O-ringen - Pakninger

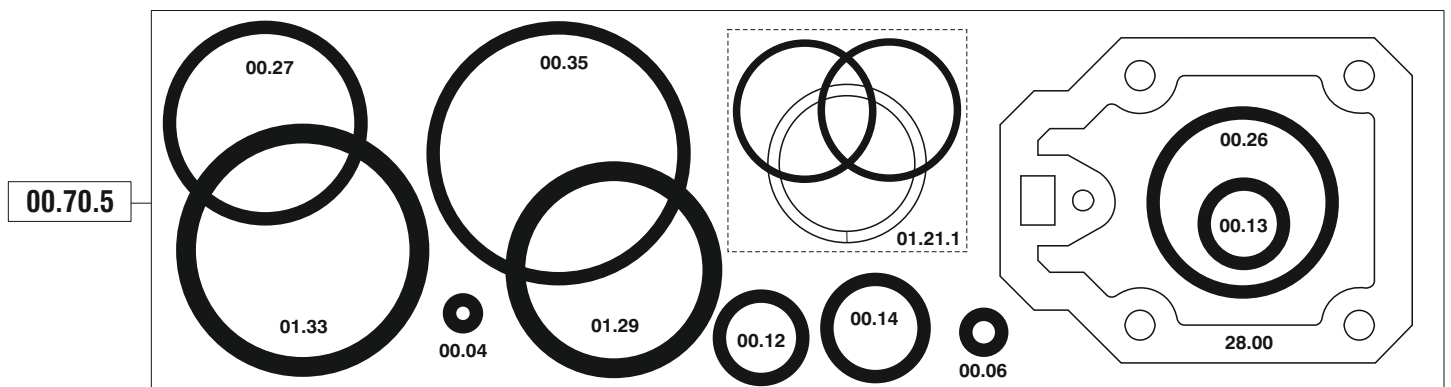

MG.30 ACD1

cod. 1140810ACD1

Indice di modifica  
Upgrade number

4

4403288