

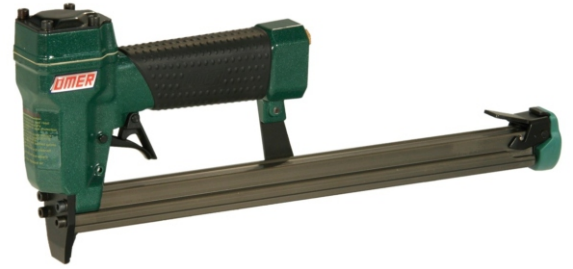

| | |
|-----------------------------------------------------------------------|-----------------|
| Manuale d'uso, manutenzione e parti di ricambio | Parte 2 |
| Use, maintenance and spare parts manual | Part 2 |
| Gebrauchsanweisung, Instandhaltungsrichtlinien und Ersatzteile | Teil 2 |
| Manuel d'utilisation, entretien et pièces de rechange | Partie 2 |
| Manual de uso, mantenimiento y repuestos | Part 2 |
| Εγχειρίδιο χρήσης, συντηρησης και ανταλλακτικών | 2° Μέρος |
| Manual de utilização, manutenção e partes sobresselentes | Parte 2 |
| Handleiding voor gebruik, onderhoud en reservedelslste | Deel 2 |
| Brugsanvisning, vedligeholdelse og reservedelslste | Del 2 |



54.16 CL

cod. 11434530

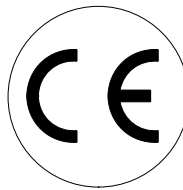

11434530_5416CL_6 120618 IV

| Dati tecnici Technical data Technische daten | Données techniques Datos tècnicos Τεχνικά χαρακτηριστικά | Dados tècnicos Technische gegevens Tecniske data |
|------------------------------------------------------------------------------------------------------------------------------------------------------------------------------------------------------|-------------------------------------------------------------------------------------------------------------------------------------------------------------------------------------------------------------------|---------------------------------------------------------------------------------------------------------------------------------------------------------------------------|
| Misure impiegabili mm Usable lengths mm Gebrauchliche Längen mm | Mesures utilisable mm Medidas que se pueden emplear mm Διαστάσεις σε μμ | Medidas que se podem utilizar mm Te gebruiken engtes in mm Brugbare længder i mm |
| Capacità caricatore n° punti Magazine capacity No. of fasteners Magazinkapazität Nägel | Capacité chargeur n° de points Capacidad cargador n° puntos Δυνατότητα γεμιστέρα, σπινδότερες | Capacidade carregador n° pontos Capaciteit magazijn in aantal spijkers Kapacitet af magasin antal klemme |
| Pressione d'esercizio Working pressure Betriebsdruck | Pression de fonctionnement Presión de trabajo Πίεση λειτουργίας ατμ. | Pressao de trabalho Werkdruk Arbejds tryk bar |
| Consumo aria litri/colpo Air consumption litres/shot Luftverbrauch Liter/Schlag | Consommation air litre/coup Consumo aire-litros/golpe Καταναλοση αερα λξτωπημα | Consumo ar litro/golpe Luchtverbruik liter/schot Luftforbrug liter/skud |
| Peso kg Weight kg Gewicht kg | Poids kg Peso kg Βαρος κγ | Peso kg Gewicht in kg Vaegt kg |
| Dimensioni (AxBxH) mm Dimensions mm Größe mm | Dimension mm Dimensiones mm Δυνατότητα γεμιστέρα, σπινδότερες | Dimencoes mm Afmetingen in mm Dimensioner mm |
| EN 12549 :1999 ISO 11201 :1995 | | |
| Pressione sonora in pos. operatore Sound pressure at the workstation Lärmintensität am Arbeitsplatz | Pression acoustique près de l'opérateur Presión sonora en posición encargado Ακουστική πίεση στη θέση χειριστού | Intensidade sonora perto do operador Geluidssterkte op de werkplek Lydstyrke på operatorposten |
| EN 12549 :1999 ISO 3744 :1994 | | |
| Potenza sonora emessa Emitted sound power Ausgestrahlte Lärmintensität | Puissance acoustique émise Potencia sonora emitida Ακουστική ισχυ | Potência sonora emitida Uitgestraalde geluidssterkte Udsendt lydstyrke |
| EN 28662 :1992 ISO 5349 :1986 ISO 8662 -11 | | |
| Valore medio ponderato di vibrazione sull'impugnatura max.33 colpi Weighted mean value of vibration on the grip max.33 shots Mittlerer Vibrationswert, am Griff gemessen max.33 Schläge | Valeur moyenne pondérée de vibration mesurée sur la poignée max.33 coups Valor medio ponderado de vibracion medida en la empuñadura max.33 golp Μεσοσ ορος μετρησις κραδασιμον στη χειρολαβη μαξ.33 ξτωπημα | Valor medio ponderado de vibracao medida no punho max.33 golpes Gewogen gemiddelde vibratiewaarde max.33 schot Middelveardi af vibrationer pa handtaget max.33 skud |

Tipo di punto
Type of fastener
Befestigungselement
Type d'agrafe
Tipo de punto
Τυπος κορφιου
Tipo de ponto
Type nietjes
Tilspændingstype

54

0,50x1,25

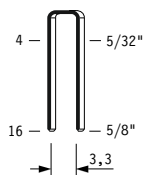

Crown: .173" (3/16")
Thickness: .022"
Width: .050"
Gauge: 20

Parti di ricambio - Spare parts - Ersatzteile - Pièces de rechange - Piezas de repuesto
 Ανταλλακτικά - Partes sobresselentes - Tabel te raadplegen - Reservedele

| Cod. | Descrizione | Description |
|----------|---------------------|-------------------|
| 00.06 | O-Ring | O-Ring |
| 00.12 | O-Ring | O-Ring |
| 00.13 | O-Ring | O-Ring |
| 00.14 | O-Ring | O-Ring |
| 00.26 | O-Ring | O-Ring |
| 00.27 | O-Ring | O-Ring |
| 00.35 | O-Ring | O-Ring |
| 01.21.1 | Guarnizione | Gasket |
| 01.21.3 | Guarnizione | Gasket |
| 01.29 | O-Ring | O-Ring |
| 01.33 | O-Ring | O-Ring |
| 04.06.5 | Vite | Screw |
| 04.10 | Vite | Screw |
| 04.12 | Vite | Screw |
| 04.16 | Vite | Screw |
| 04.20 | Vite | Screw |
| 04.35 | Vite | Screw |
| 07.05 | Sfera | Ball |
| 07.30 | Chiave esagonale | Hex. bar wrench |
| 09.02 | Anello elastico | Elastic ring |
| 14.18.1 | Spina | Pin |
| 20.00 | Corpo | Body |
| 22.00 | Testa | Head |
| 24.00 | Silenziatore | Silencer |
| 25.04 | Deflettore | Exhaust deflector |
| 26.07 | Cilindro | Cylinder |
| 28.00 | Guarnizione | Gasket |
| 30.07.3 | Pistone | Piston |
| 32.05 | Ammortizzatore | Bumper |
| 39.00 | Guarnizione scarico | Exhaust gasket |
| 40.04.2 | Valvola completa | Valve ass'y |
| 45.04 | Anello valvola | Ring |
| 54.03 | Pulsante | Trigger valve |
| 55.06 | Raccordo | Bush |
| 70.04 | Protezione | Guard |
| 72.03.1 | Reggicaricatore | Support |
| 72.06 | Fermo carrello | Slider-stop |
| 76.04 | Perno | Pin |
| 76.14 | Perno | Pin |
| 76.45 | Perno molla | Pin |
| 80.08 | Grilletto chiusura | Trigger |
| 81.09 | Grilletto comando | Trigger |
| 81.15 | Controgrilletto | Safety |
| 90.07 | Molla | Spring |
| 90.10 | Molla | Spring |
| 91.03X | Molla | Spring |
| 92.01X | Molla | Spring |
| 22.00.54 | Battente | Driver |
| 53.05.41 | Caricatore | Magazine |
| 63.05.41 | Carrello | Slider |
| 73.05.41 | Spingipunto | Pusher |
| 81.00.80 | Controtestina | Nose |
| 91.00.54 | Testina | Nose plate |
| D01 | Bocchetta olio | Oiler |

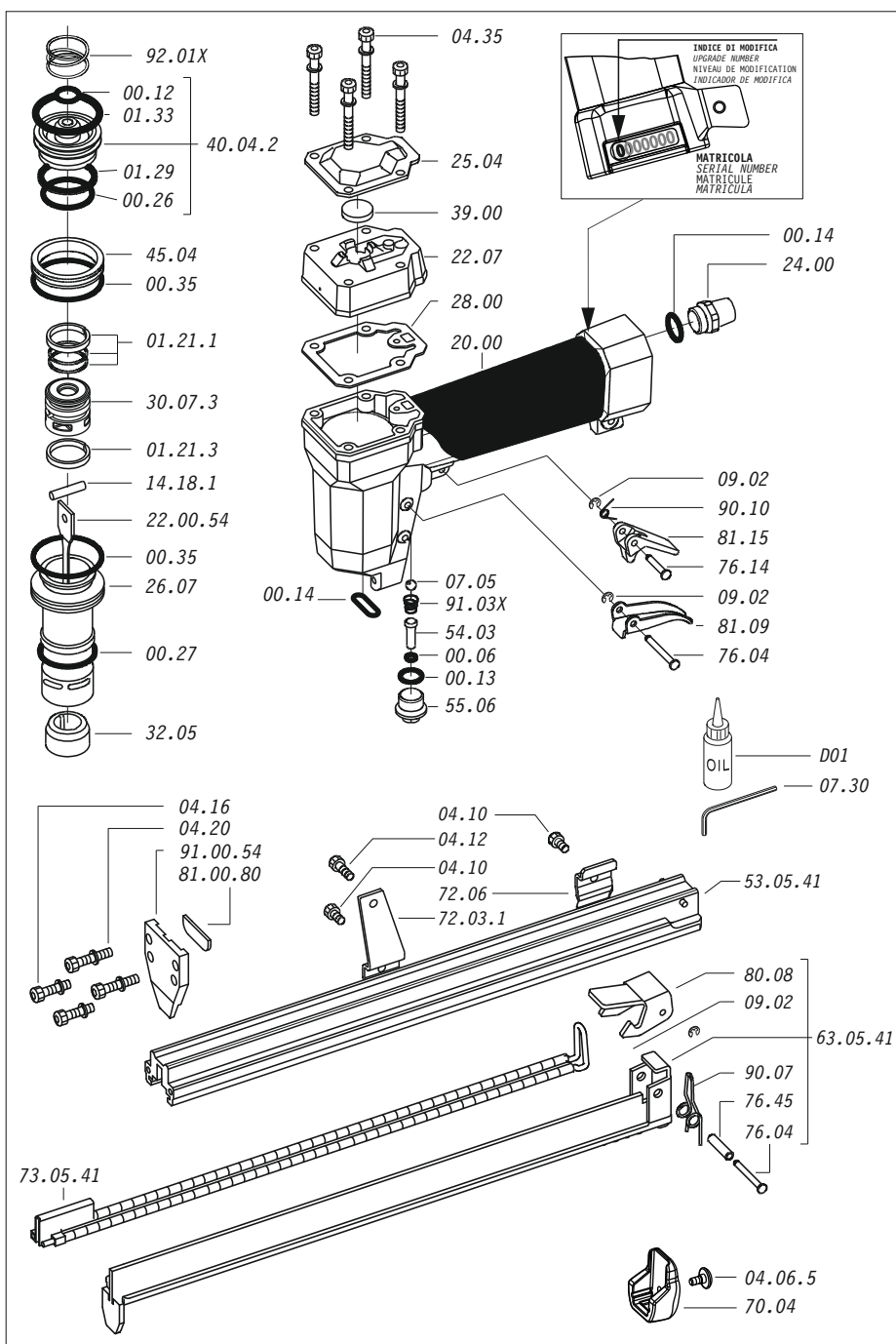

Guarnizioni - O-Rings - Dichtungen - Joints - Kit O-Ring - Λαστιχακια - Kit O-Ring - O-ringen - Pakninger

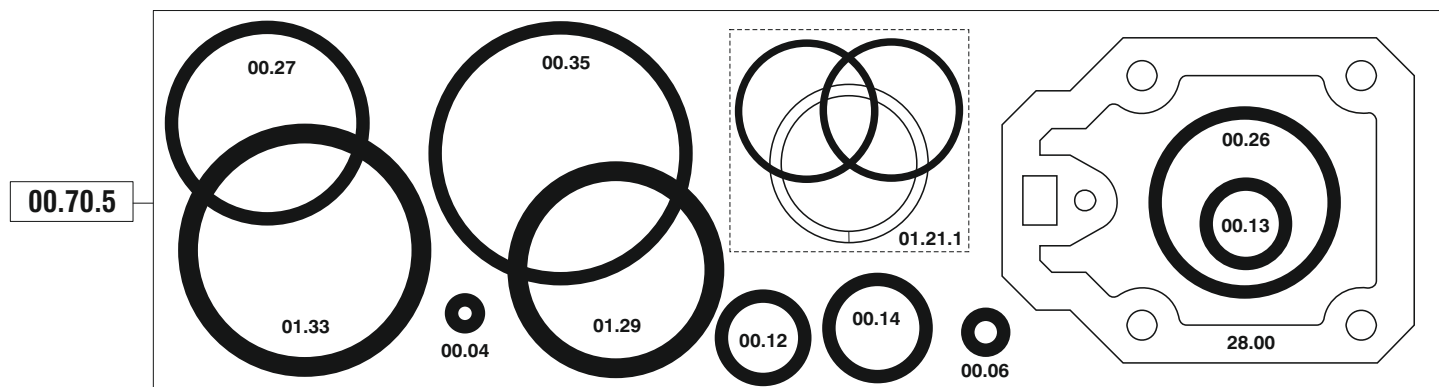

54.16 CL

cod. 11434530

Indice di modifica
Upgrade number

6

6322274