

## Collegamento - Connection

**Collegamento:**  
Connection:

**Valvola 3/2 NA**  
Valve 3/2 NO

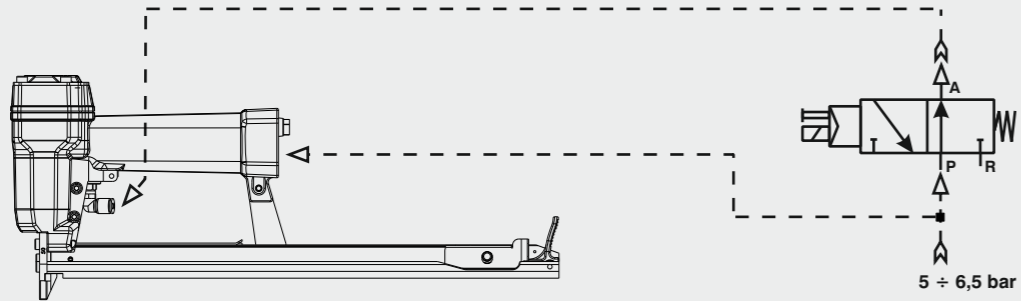

## Caricamento - Loading

**1 - Arretrare lo spingipunto e agganciarlo al finecorsa**

Pull the pusher backwards and lock it at the stop position at the rear of the tool

**2 - Inserire le graffe**

Load the magazine with Staple

**3 - Rilasciare lo spingipunto**  
Release the the pusher

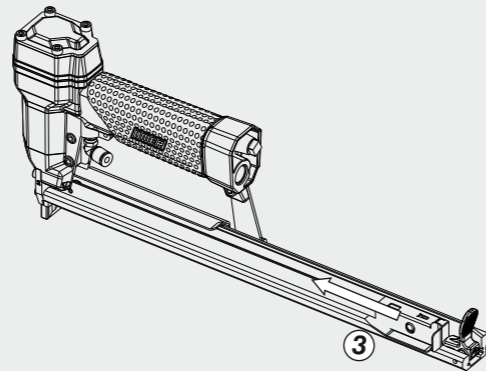
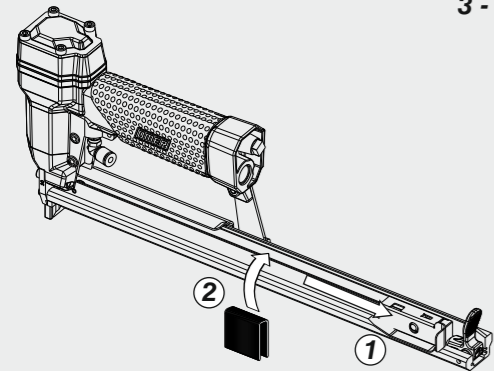

**Non azionare MAI la valvola comando durante il caricamento o il disinceppamento della graffatrice.**  
NEVER actuate the command valve while loading or cleaning a jammed stapler.

# OMER

**Manuale d'uso, manutenzione e parti di ricambio**  
**Use, maintenance and spare parts manual**  
**Gebrauchsanweisung, Instandhaltungsrichtlinien und Ersatzteile**  
**Manuel d'utilisation, entretien et pièces de rechange**  
**Manual de uso, mantenimiento y repuestos**  
**Εγχειρίδιο χρήσης, συντηρησης και ανταλλακτικών**  
**Manual de utilização, manutenção e partes sobresselentes**  
**Handleiding voor gebruik, onderhoud en reservedelslste**  
**Brugsanvisning, vedligeholdelse og reservedelslste**

**Parte 2**  
**Part 2**  
**Teil 2**  
**Partie 2**  
**Part 2**  
**2° Μερὸς**  
**Parte 2**  
**Deel 2**  
**Del 2**

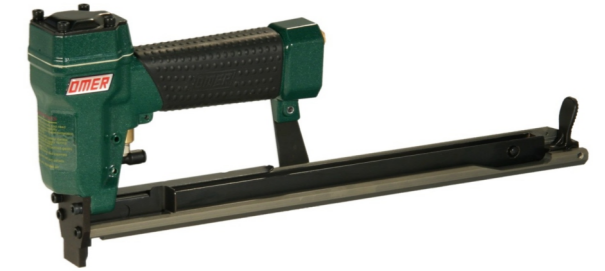

# 80.16 CLT

cod. 11460520

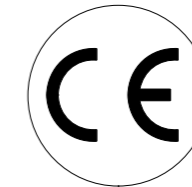

11460520\_8016CLT\_6 100510 IV

Dati tecnici Technical data Technische daten	Données techniques Datos tècnicos Τεχνικά χαρακτηριστικά	Dados tècnicos Technische gegevens Teknische data
--	--	---

<b>Misure impiegabili mm</b> Usable lengths mm Gebrauchliche Längen mm	Mesures utilisables mm Medidas que se pueden emplear mm Διαστάσεις σε mm	Medidas que se podem utilizar mm Te gebruiken engtes in mm Brugbare laengder i mm	<b>4 ÷ 16</b>
<b>Capacità caricatore n° punti</b> Magazine capacity No. of fasteners Magazinkapazität Nägel	Capacité chargeur n° de points Capacidad cargador n° puntos Δυνατότητα γεμιστέρα, σπινδτερες	Capacidade carregador n° pontos Capaciteit magazijn in aantal spijkers Kapacitet af magasin antal klemme	<b>270</b>
<b>Pressione d'esercizio</b> Working pressure Betriebsdruck	Pression de fonctionnement Presión de trabajo Πίεση λειτουργίας ατμ.	Pressão de trabalho Werkdruk Arbejds tryk bar	<b>4 ÷ 6 bar</b> <b>60 ÷ 90 psi</b>
<b>Consumo aria litri/colpo</b> Air consumption litres/shot Luftverbrauch Liter/Schlag	Consommation air litre/coup Consumo aire-litros/golpe Κατανάλωση αέρα λ/ξτππημα	Consumo ar litro/golpe Luchtverbruik liter/schot Luftforbrug liter/skud	<b>0,13</b>

<b>Peso kg</b> Weight kg Gewicht kg	Poids kg Peso kg Βαρος κγ	Peso kg Gewicht in kg Vaegt kg	<b>1,10</b>
<b>Dimensioni (AxBxH) mm</b> Dimensions mm Größe mm	Dimension mm Dimensiones mm Δυνατότητα γεμιστέρα, σπινδτερες	Dimencoes mm Afmetingen in mm Dimensioner mm	<b>362x43x148</b>

EN 12549 :1999	ISO 11201 :1995	
<b>Pressione sonora in pos. operatore</b> Sound pressure at the workstation Lärmintensität am Arbeitsplatz	Pression acoustique près de l'opérateur Presión sonora en posición encargado Ακουστική πίεση στη θέση χειριστού	Intensidade sonora perto do operador Geluidssterkte op de werkplek Lydstyrke på operatorposten
		<b>84,3 dB(A)</b>

EN 12549 :1999	ISO 3744 :1994	
<b>Potenza sonora emessa</b> Emitted sound power Ausgestrahlte Lärmintensität	Puissance acoustique émise Potencia sonora emitida Ακουστική ισχύ	Potência sonora emitida Uitgestraalde geluidssterkte Udsendt lydstryrke
		<b>93,7 dB(A)</b>

EN 28662 :1992	ISO 5349 :1986	ISO 8662 -11
<b>Valore medio ponderato di vibrazione sull'impugnatura max.33 colpi</b> Weighted mean value of vibration on the grip max.33 shots Mitteler Vibrationswert, am Griff gemessen max.33 Schäge	Valeur moyenne pondérée de vibration mesurée sur la poignée max.33 coups Valor medio ponderado de vibracion medida en la empunadura max.33 golp Μεσος ορος μετρησης κραδασιμον στη χειρολαβη max.33 ξτππημα	Valor medio ponderado de vibracao medida no punho max.33 golpes Gewogen gemiddelde vibratiewaarde max.33 schot Middelvaerdi af vibrationer pa handtaget max.33 skud
		<b>&lt;2,5 m/s<sup>2</sup></b>

**Tipo di punto**  
Type of fastener  
Befestigungselement  
Type d'agrafe  
Tipo de punto  
Τυπος κάρφιου  
Tipo de ponto  
Type nietjes  
Tilspændingstype

**80**

0,65x0,95

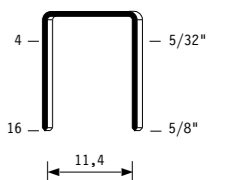

Crown: .500" (1/2")  
Thickness: .025"  
Width: .037"  
Gauge: 21

## Disinceppamento macchina - Quick clearance jammed nails

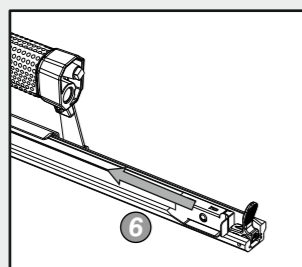
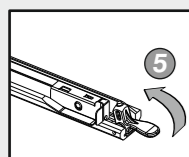
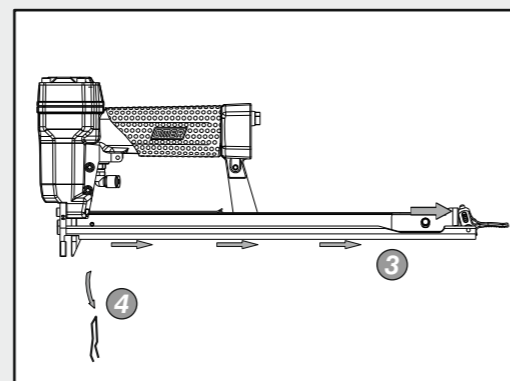
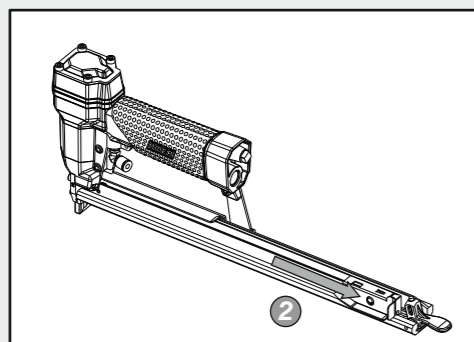
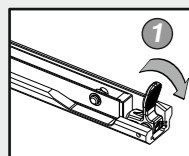

Parti di ricambio - Spare parts - Ersatzteile - Pièces de rechange - Piezas de repuesto  
Ανταλλακτικά - Partes sobresselentes - Tabel te raadplegen - Reservedele

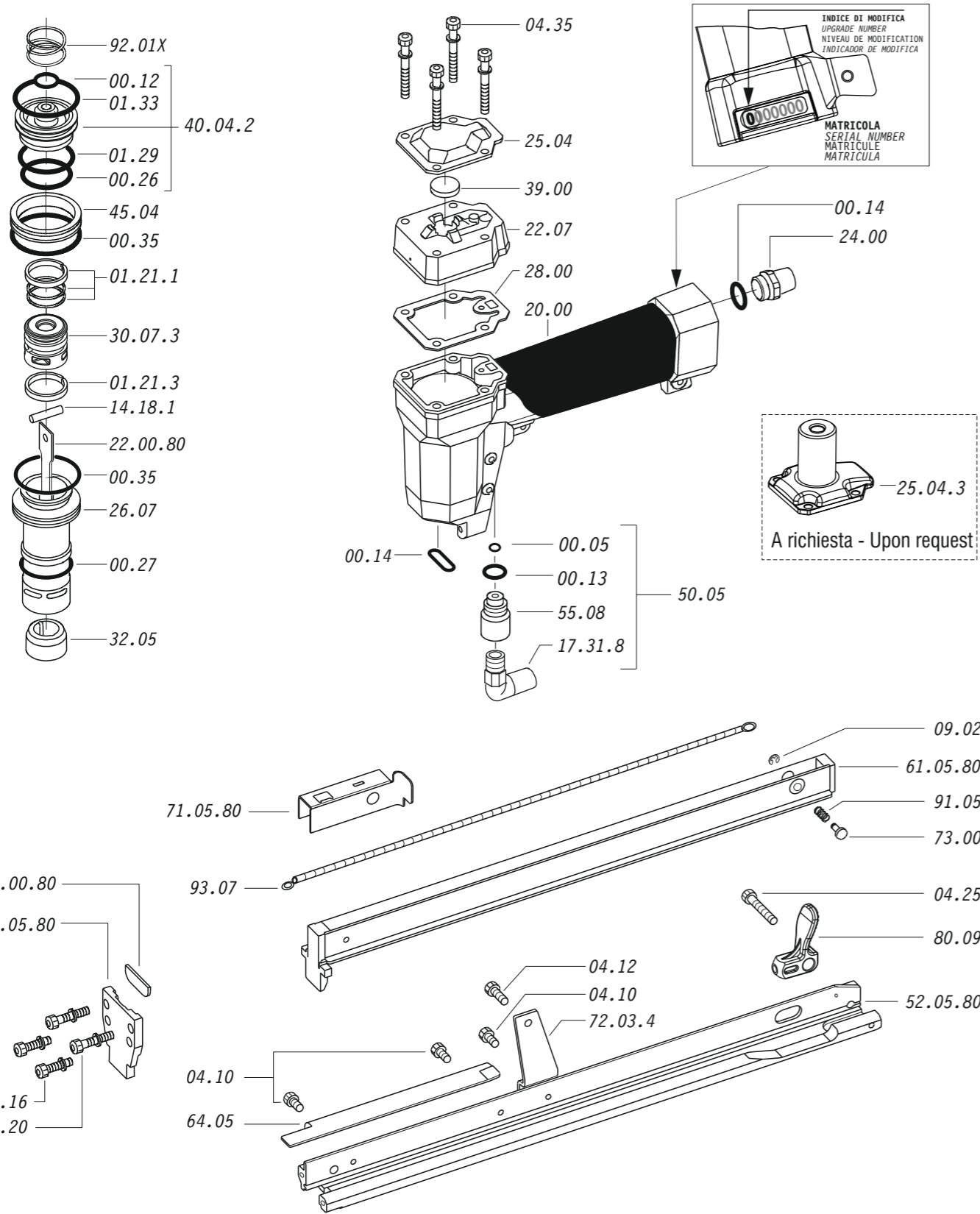

Dotazioni - Equipment - Ausrüstung - Équipements - Equipamiento - Παρεχόμενα  
Equipamento - Uitrusting - Udstyr

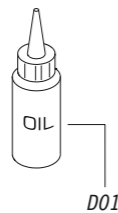

**80.16 CLT**

cod. 11460520

Parti di ricambio - Spare parts - Ersatzteile - Pièces de rechange - Piezas de repuesto  
Ανταλλακτικά - Partes sobresselentes - Tabel te raadplegen - Reservedele

Cod.	Descrizione	Description
00.05	O-Ring	O-Ring
00.12	O-Ring	O-Ring
00.13	O-Ring	O-Ring
00.14	O-Ring	O-Ring
00.26	O-Ring	O-Ring
00.27	O-Ring	O-Ring
00.35	O-Ring	O-Ring
01.21.1	Guarnizione	Gasket
01.21.3	Guarnizione	Gasket
01.29	O-Ring	O-Ring
01.33	O-Ring	O-Ring
04.10	Vite	Screw
04.12	Vite	Screw
04.16	Vite	Screw
04.20	Vite	Screw
04.25	Vite	Screw
04.35	Vite	Screw
07.30	Chiave esagonale	Hex. bar wrench
09.02	Anello elastico	Elastic ring
14.18.1	Spina	Pin
17.31.8	Attacco	Connection
20.00	Corpo	Body
22.07	Testa	Head
24.00	Silenziatore	Silencer
25.04	Deflettore	Exhaust deflector
26.07	Cilindro	Cylinder
28.00	Guarnizione	Gasket
30.07.3	Pistone	Piston
32.05	Ammortizzatore	Bumper
39.00	Guarnizione scarico	Exhaust gasket
40.04.2	Valvola completa	Valve ass'y
45.04	Anello valvola	Ring
50.05	Comando a distanza	Remote control trigger
55.08	Raccordo	Bush
64.05	Carter	Hold down
72.03.4	Reggicaricatore	Support
73.00	Perno	Pin
80.09	Grilletto chiusura	Trigger
91.05	Molla	Spring
92.01X	Molla	Spring
93.07	Molla	Spring
22.00.80	Battente	Driver
52.05.80	Caricatore	Magazine
61.05.80	Carrello	Slider
71.05.80	Spingipunto	Pusher
81.00.80	Controtestina	Nose
91.05.80	Testina	Nose plate
D01	Bocchetta olio	Oiler

Guarnizioni - O-Rings - Dichtungen - Kits - Kit O-rings - Λοστίγια - O-rings - Pakninger

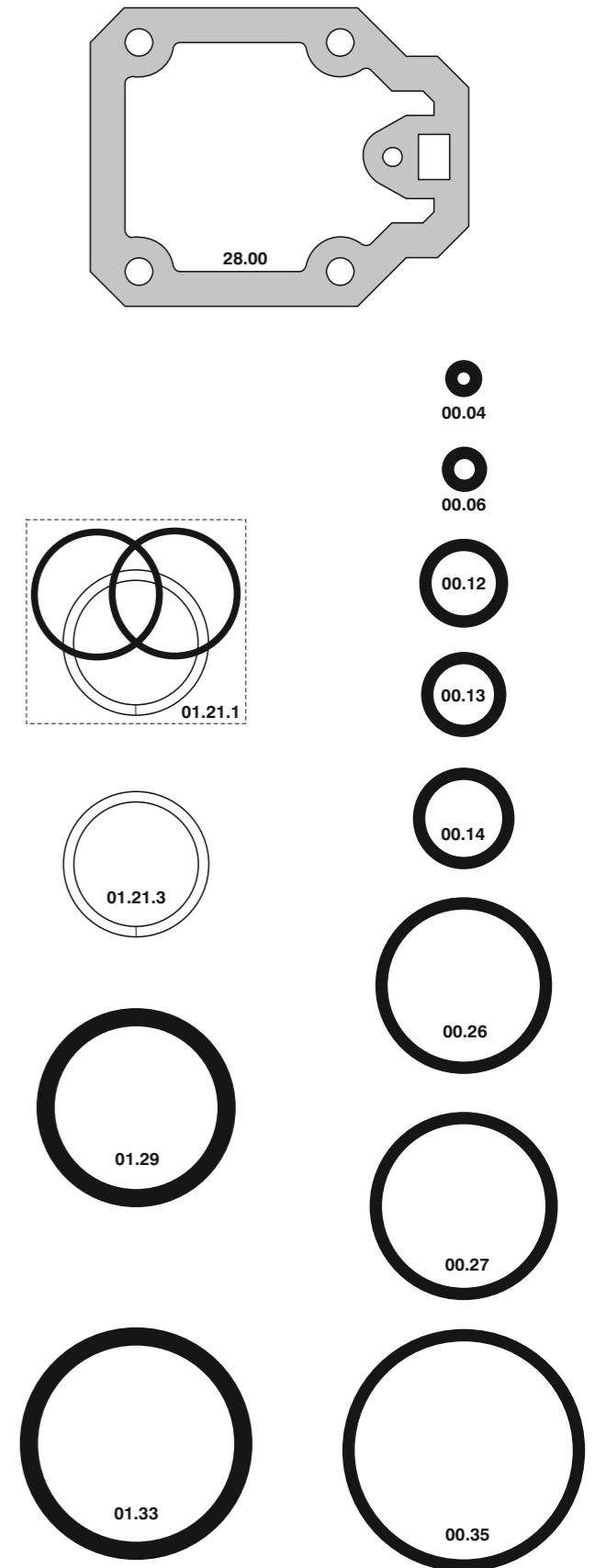

11460520\_8016CLT\_6\_100510\_IV

**80.16 CLT** cod. 11460520

Indice di modifica  
Upgrade number

**6**

6019800